



معاونت خدمات پس از فروش

راهنمای تعمیرات

معرفی و جانمایی دسته‌سیمها و نقشه‌های

الکتریکی

خودروی هایما S7

کلید مدرک ۱۵۶۳۸

تابستان ۱۳۹۴

## فهرست

English.....	Code.....	پارسی.....
Ground point.....	Y.....	اتصالات بدنه.....
Electric harness schematic.....	W-1, W-2.....	شماتیک دسته سیم ها.....
Charging system & Starting system.....	A-1.....	سیستم شارژ و سیستم استارت.....
Start-stop Start-up system.....	A-2.....	سیستم Start/Stop.....
Engine control system (484Q) .....	B-1a, B-1b, B-1c, B-1d.....	سیستم سوخت رسانی و موتور.....
Transmission Control System (AT) .....	B-2a, B-2b.....	گیربکس اتوماتیک.....
Fuel pump control system.....	B-7.....	پمپ بنزین.....
Fan Control system.....	B-8.....	سیستم خنک کننده موتور.....
Combination instrument.....	1a, C-1b, C-1c, C-1d, C-1e, C-1f, C-1g.....	جلو آمپر.....
Windshield wiper and washer.....	D-1a.....	برف پاک کن و شیشه شور جلو.....
Rear-window wiper and washer.....	D-1b.....	برف پاک کن و شیشه شور عقب.....
Headlamp.....	E-1.....	چراغهای اصلی.....
Headlamp beam level adjusting system.....	E-2.....	تنظیم ارتفاع چراغ های اصلی.....
Front/rear fog lamp.....	E-5.....	چراغهای مه شکن جلو و عقب.....

License plate lamp/Position lamp/Tail lamp/Daytime running lamp.....	E-7.....	چراغهای جانبی
Turn indicator and hazard warning lamp.....	F-1.....	چراغهای راهنما و فلاشر
Reversing lamp.....	F-2.....	چراغ دنده عقب
Brake lamp.....	F-3.....	چراغ ترمز
Horn.....	F-4.....	بوق
Air conditioning system.....	G-1a, G-1b.....	سیستم تهویه مطبوع
Compressor control system.....	G-2.....	کمپرسور کولر
Reversing radar system.....	H-1.....	سیستم هشدار موانع عقب
Rear vision system.....	H-2.....	سیستم دوربین دنده عقب
Cigarette lighter and Rear defroster system.....	I-1.....	فندک و گرمکن شیشه عقب
Illumination lamp.....	I-2a, I-2b, I-2c.....	چراغهای روشنایی داشبورد
Interior lamp/Reading lamp/Trunk lamp.....	I-3.....	چراغهای سقفی و صندوق
Sound system.....	J-1a J-1b.....	سیستم صوتی و تصویری
Power window system.....	K-1.....	سیستم Power window
Remote and central door lock system.....	K-2a, K-2b, K-2c, K-2d.....	سیستم قفل مرکزی
Exterior rearview mirror heater/Power exterior rearview mirror.....	L.....	آینه های جانبی
Sunroof and auto-dimming interior rearview mirror.....	M.....	سانروف و آینه وسط

Anti-lock braking system.....	O-1a, O-1b.....	سیستم ESP و ABS
Smart Key System (PEPS) .....	N-1a, N-1b, N-1c.....	سیستم کلید هوشمند
Body Control System (BCM) .....	N-2a, N-2b.....	نود BCM
Power Supply System (without smart key) .....	Z-1a, Z-1b.....	تغذیه سیستم های مختلف (با کلید هوشمند)
Power Supply System (with smart key) .....	Z-2a, Z-2b.....	تغذیه سیستم های مختلف (بدون کلید هوشمند)
Power seat and seat heating.....	P.....	صندلی ها
Electronic Power Steering system (EPS) .....	Q.....	سیستم فرمان الکترونیکی
Airbag/Seat belt pretensioner system.....	S.....	کیسه هوا و کمربند پیش کشنده
Anti-theft system.....	T.....	سیستم ضد سرقت
Diagnosis link connector (DLC) .....	U-1.....	کانکتور عیب یابی
Communication wire (CAN) .....	U-2a, U2b.....	شبکه CAN
Fuse box wiring diagram.....	FB.....	فیوز ها و رله های محفظه موتور
Common Connector list.....	X-1, X-2, X-3, X-4.....	اینترکانکتور ها
Junction box wiring diagram.....	JB.....	فیوز های داخل اتاق

نقشه خوانی:

استاندارد این نقشه های الکتریکی بگونه ای است که نقشه های شماتیک هر سیستم را به صورت جداگانه ترسیم نموده و در پایین هر صفحه مشخصات کانکتور های مورد استفاده در آن نقشه آورده شده است. همچنین صفحه بعدی هر نقشه الکتریکی نقشه جانمایی اینترکانکتور ها و کانکتور های مورد استفاده در آن نقشه ترسیم شده است. به غیر از نقشه های الکتریکی و نقشه جانمایی قطعات، نقشه های فیوز ها و رله ها و همچنین اینترکانکتور ها نیز به صورت جداگانه ترسیم شده و در انتهای مستند آورده شده است.

هر نقشه با یک کد مشخص می شود و برای شناسایی هر نقشه نیاز به کد آن داریم. کدها به صورت حروف لاتین و در اکثر آنها به همراه یک عدد می باشد. نقشه ها بر اساس ترتیب حروف الفبای لاتین مرتب شده اند. بنابراین جهت یافتن هر نقشه در کتاب به کد احتیاج داریم. در هر نقشه با توجه به نیاز آن نقشه ممکن است به چندین نقشه دیگر احتیاج داشته باشیم که نقشه های مورد نیاز با ذکر کد آنها در هر نقشه آورده شده است. در ادامه جدول کلی معرفی نقشه های تمامی سیستم ها و نقشه های مرتبط با هر سیستم آورده شده است. تمامی ارتباطات الکتریکی به صورت تجمیع شده در صفحه های W-1 و W-2 آمده است.

ارتباط نقشه ها با یکدیگر در هر نقشه توسط یک عدد داخل یک دایره و نام قطعه مربوط و در زیر آن کد نقشه مرتبط نوشته شده است. به طور مثال در نقشه سیستم Start-Stop علامت ذیل نشان دهنده ارتباط بخشی از نقشه با نقشه ای با کد B-1a و قطعه رله اصلی (Main relay) می باشد :



در نقشه با کد B-1a که یکی از نقشه های سیستم سوخت رسانی و موتور میباشد نیز همین شماره (320) جهت ردیابی و قطعه مرتبط (سوئیچ Start-Stop) در نقشه سیستم Start-Stop با کد A-2 نوشته شده است.



بر روی هر سیم کدی وجود دارد که نشان دهنده رنگ و دسته سیم آن می باشد. حروف خارج از پرانتز یعنی در این مثال B/W نشان دهنده رنگ سیم و همچنین حروف داخل پرانتز نشان دهنده دسته سیم می باشد. جدول معرفی کد رنگ ها و دسته سیم ها در صفحات اولیه کتاب آورده شده است.



در مسیر سیم ها برای نشان دادن وجود اینترکانکتور از علامت زیر استفاده می شود. در این کتاب کد X نشاندهنده اینترکانکتور می باشد. به طور مثال اینترکانکتور X-05 مربوط به ارتباط بین دسته سیم EM (دسته سیم بزرگ موتور) و

دسته سیم جلو آمپر می باشد. جدول معرفی تمامی اینترکانکتور ها در صفحات آخر کتاب با کد های X-1 تا X-4 آمده است.

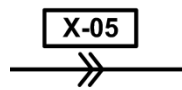

برای نشان دادن کانکتور ها از علامتهایی نظیر علامت زیر استفاده می شود. به طور مثال علامت زیر نشان دهنده آنست که کد کانکتور قطعه مذکور A2-04 می باشد و هر دو سیم بالایی و پایینی در آن قرار دارند. مشخصات کلی هر کانکتور، در پایین صفحه همان نقشه ای که در آن بکار رفته است وجود دارد.

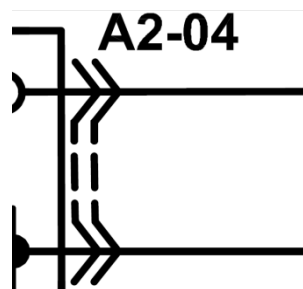

در نقشه های دسته سیم از شماره سیم استفاده نشده است و جهت ردیابی هر مسیر تنها به رنگ سیم و محل قرار گیری در کانکتور بسنده شده است. مانند شکل زیر که کانکتور A2-04 را که مربوط به رله Start-Stop می باشد را نشان داده است.

A2-04 Start-stop control relay (EM)

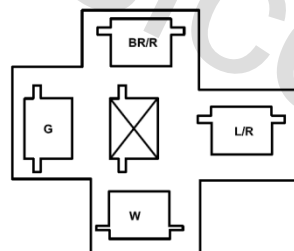

جهت ردیابی ارتباطات سیم ها در نقشه های فیوزها و رله ها داخل محفظه موتور و اتاق (JB و FB) بایستی از علامت ها زیر استفاده نمود.

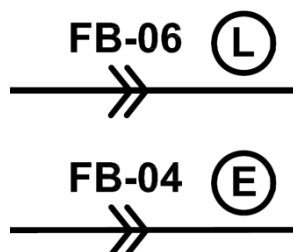

به طور مثال خط ارتباط بالایی نشاندهنده این است که به نقشه FB در بخش FB-06 خط L و برای ارتباط پایینی در نقشه FB در بخش FB-04 خط E مراجعه گردد.

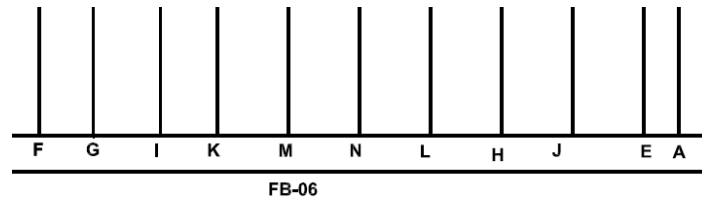

[www.nasicoelec.ir](http://www.nasicoelec.ir)

دیف	بخش	زبر بخش	عنوان نقشه	نقشه های اصلی	نقشه های مرتبط
۱	سیستم سوخت رسانی جرقه	۱	سیستم سوخت رسانی و جرقه	B-1a, B-1b, B-1c, B-1d	G-1b, B-7, B-8, G-2, A-2, Z-1b, Z-2b, F-3, U-2a, T, U, I-1
۲	سیستم خنک کننده موتور (فن ها)	۱	سیستم خنک کننده موتور (فن ها)	B-8	B-1a, B-1c
۳	سیستم ترمز	۱	ترمز ABS	O-1a, O-1b	Z-1b, Z-2b, U-2b, F-3, U, N-1c, N-2b, J-1b, K-2d, U-1, G-1a, C-1d
		۲	سیستم ESP	O-1a, O-1b	Z-1b, Z-2b, U-2b, F-3, U, N-1c, N-2b, J-1b, K-2d, U-1, G-1a, C-1d
۴	سیستم های حفاظتی و هشدار دهنده	۱	قفل مرکزی	K-2a, K-2b, K-2c K-2d	N-1b, S, F-4, N-2a, Z-1b, Z-2b, O-1a, C-1c, I-3, C-1b
		۲	کیسه هوا و کمربندهای پیش کشنده	S	N-2b, K-2d, Z-1b, Z-2b, U, C-1d
		۳	ایموبلایزر	T	Z-1b, Z-2b, C-1f, B-1d, U, U-2
		۴	قفل صندوق عقب (صندوق بران)	K-2c	K-2d, N-2a
		۵	سیستم دزدگیر	T	Z-1b, Z-2b, C-1f, B-1d, U, U-2
		۶	سنسور دنده عقب	H-1	M, F-2
		۷	بوق	F-4	N-2b, K-2d
۵	برف پاک کن شیشه شوی	۸	سیستم استارت بدون کلید	N-1a, N-1b, N-1c	B-2b, A-1, K-2d, O-1a, F-3, B-1d, C-1c, C-1e, U-2, N-2b
		۱	برف پاک کن و شیشه شوی	D-1a, D-1b	Z-1a, Z-1b, Z-2a, Z-2b
۶	سیستمهای مربوط به شیشه بالابرها	۱	شیشه بالابر جلو	K-1	Z-2b, Z-1b, N-2b
		۲	شیشه بالابر عقب	K-1	Z-2b, Z-1b, N-2b
		۳	Power Window	K-1	Z-2b, Z-1b, N-2b
		۴	Sun Roof	M	Z-2a, Z-1a, H-1
۷	سیستمهای آسایشی سرنشینان	۱	سیستم تهویه مطبوع (کولر و بخاری اتوماتیک)	G-1a, G-1b, G-2	Z-2a, Z-1a, O-1b, J-1b, B-1d, I-1, B-1c, B-1a
		۲	گرمکن شیشه عقب و آینههای جانبی	L	Z-2b, Z-1b, I-1
		۳	آینههای جانبی (تنظیم و تاشو اتوماتیک)	L	Z-2b, Z-1b, I-1
		۴	صندلی برقی	P	Z-2b, Z-1b, C-1a
		۵	سیستمهای صوتی و تصویری (رادیو پخش و ...)	J-1a J-1b	Z-2a, Z-1a, H-2, G-1a, U-2, C-1c, F-2, O-1a
		۶	فندک و شارژر	I-1	Z-1a, Z-1b, Z-2a, Z-2b, B-1d, L, G-1b
		۷	سیستم ناوبری (مسیریاب)	J-1a J-1b	Z-2a, Z-1a, H-2, G-1a, U-2, C-1c, F-2, O-1a



نقشه های مرتبط	نقشه های اصلی	عنوان نقشه	زیر بخش	بخش	دیف
C-1e, N-1a	A-1, Z-1a, Z-2a	آلترناتور و استارت	۱	آلترناتور و استارت	۸
B-1a, B-1b, U	B-7, C-1b	نمایشگر مقدار سوخت (بنزین سوز و گازسوز)	۱	نشانگرها و جلو آمپر	۹
I-2c, P, C-1c, Z-1b, Z-2b, B-1d, K-2d, O-1a, O-1b, U-2a, F-1, E-1, J-1b, N-1c, S, E-5, B-2b, N-1c, A-1, T, N-2a, B-2b	C-1a, C-1b, C-1c, C-1d, C-1e, C-1f, C-1g	صفحه نمایشگر ( پشت آمپر )	۲		
C-1a, C-1b, C-1c, C-1e, C-1f, C-1g	C-1d	نشانگر فشار روغن موتور	۳		
G-1b	B-1c, C-1b	نشانگر دمای مایع خنک کننده	۴		
C-1a, C-1d	C-1c	چراغ اخطار سطح روغن ترمز و ترمز دستی	۵		
E-1	E-7	چراغهای جانبی (پارک و پلاک)	۱		
I-2a/I-2c, P, E-7, C-1c	E-1, E-2	چراغهای اصلی و تنظیم ارتفاع چراغها	۲	سیستم روشنایی	۱۰
C-1d	E-5	مه شکن جلو و عقب	۳		
Z-1b, Z-2b, J-1a/J-1b, H-1, H-2b	F-2	چراغ دنده عقب	۴		
N-2a, N-2b, C-1c	F-1	راهنما و فلاشر	۵		
K-2d, N-2b	I-3	چراغ سقفی	۶		
N-1c, O-1a, B-1d, Z-1b, Z-2b	F-3	چراغ ترمز	۷		
C-1a, E-1	I-2a, I-2b, I-2c	سیستم تنظیم نور چراغها و نمایشگرها	۸		
B-2b, B-1c, O-1a, O-1b, Q, J-1b, C-1b, N-2a, N-1c	U-2a, U2b	نودها و یونیتها	۱		
Z-1b, Z-2b, Z-1a, N-1a, N-1c, C-1e	B-2a, B-2b	گیربکس اتوماتیک	۱	سیستم انتقال قدرت	۱۲
	FB, JB	فیوزها و رله ها	۱	فیوزها و رله ها	۱۳
B-1a, Z-1a	A-2	آپشن - Start+Stop	۱	آپشن	۱۴
F-2, J-1b	H-2	آپشن - دوربین دنده عقب	۲		
F-3, U	B-1d	آپشن - کروز کنترل	۳		
	X-1, X-2, X-3, X-4	اینترکانکتورها	۱	اینترکانکتور	۱۵





## General Wire Color Code

Color	Code	Color	Code
Black	B	Light Green	LG
Brown	BR	Orange	O
Dark blue	DL	Pink	P
Dark Green	DG	Red	R
Gray	GR	Sky Blue	SB
Green	G	Violet	V
Light blue	LB	White	W
Blue	L	Yellow	Y

# Reading Instruction For Wiring Diagram

---

## Harness symbol

Name	Symbol	Name	Symbol
Front harness	F 	Grounding harness	EA
Engjne harness	E 	Interior harness	IN
EM harness	EM	Reversing radar harness	RA
Middle harness	D 	2# Back door harness	R2#
Rear harness	R 	1# Back door harness	R1#
Front left door harness	DR1		
Front right door harness	DR2		
Rear left door harness	DR3		
Rear right door harness	DR4		
Instrument harness	I		

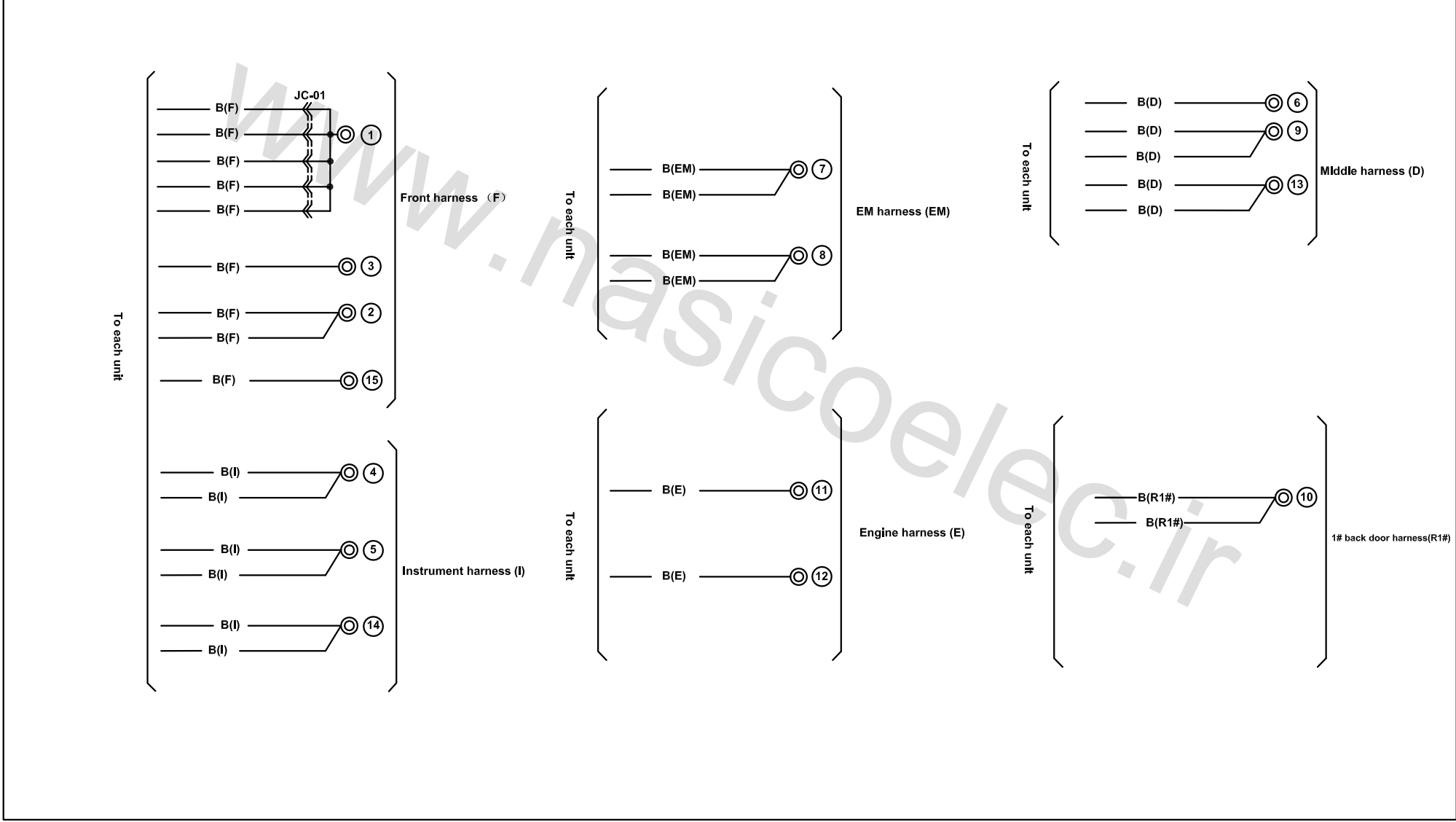
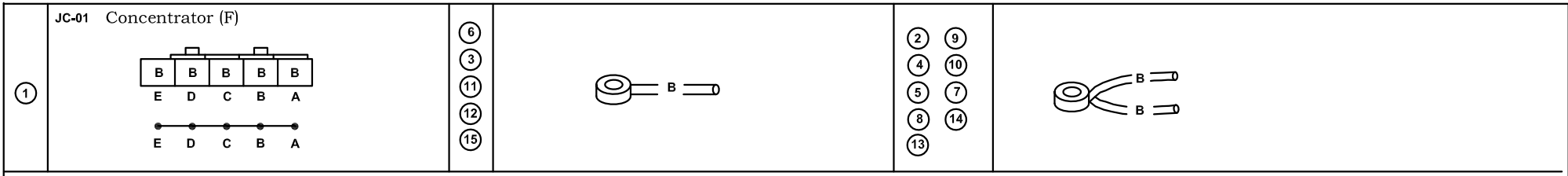

Harness mark:  (F)  (E)  (D)  (R)

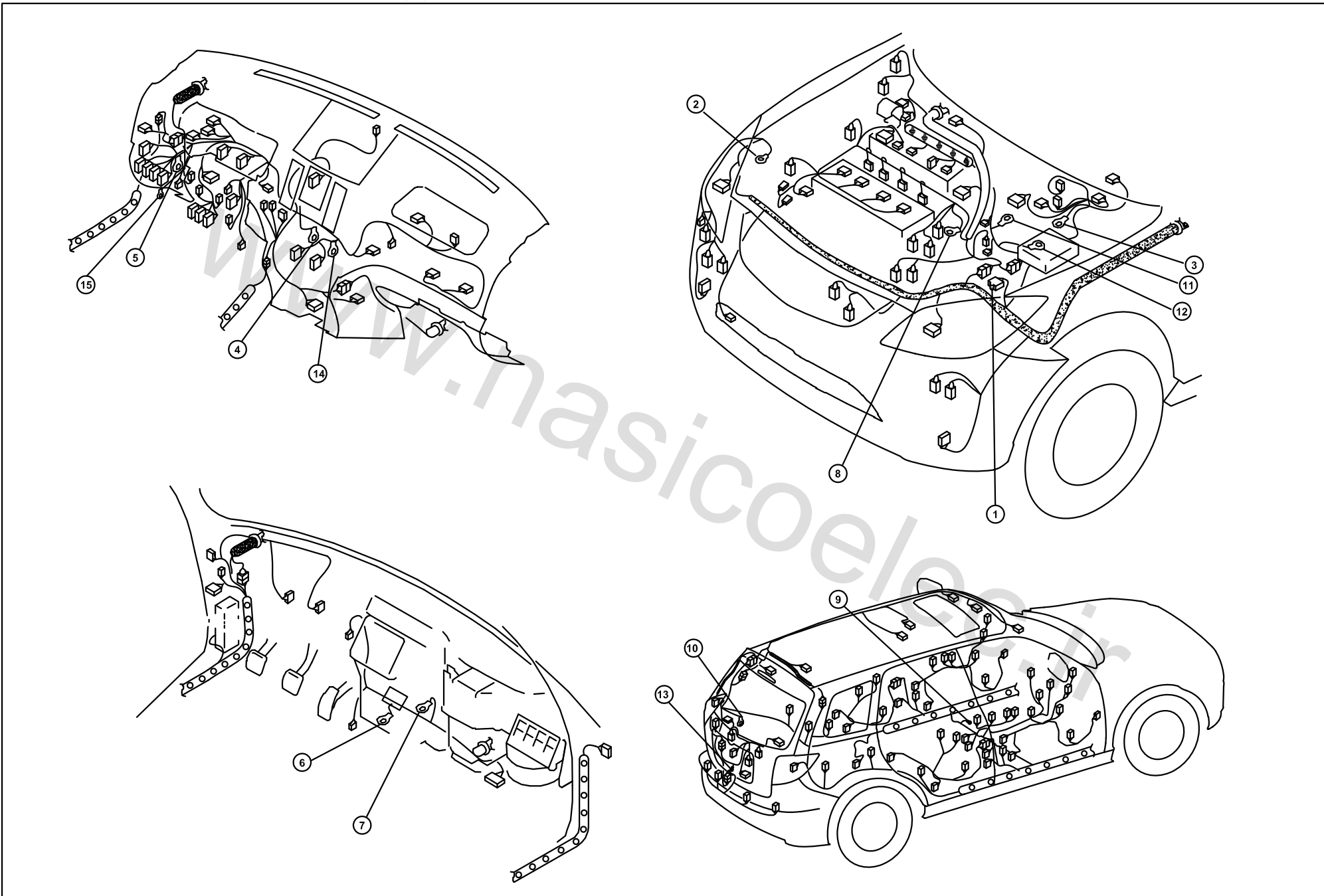

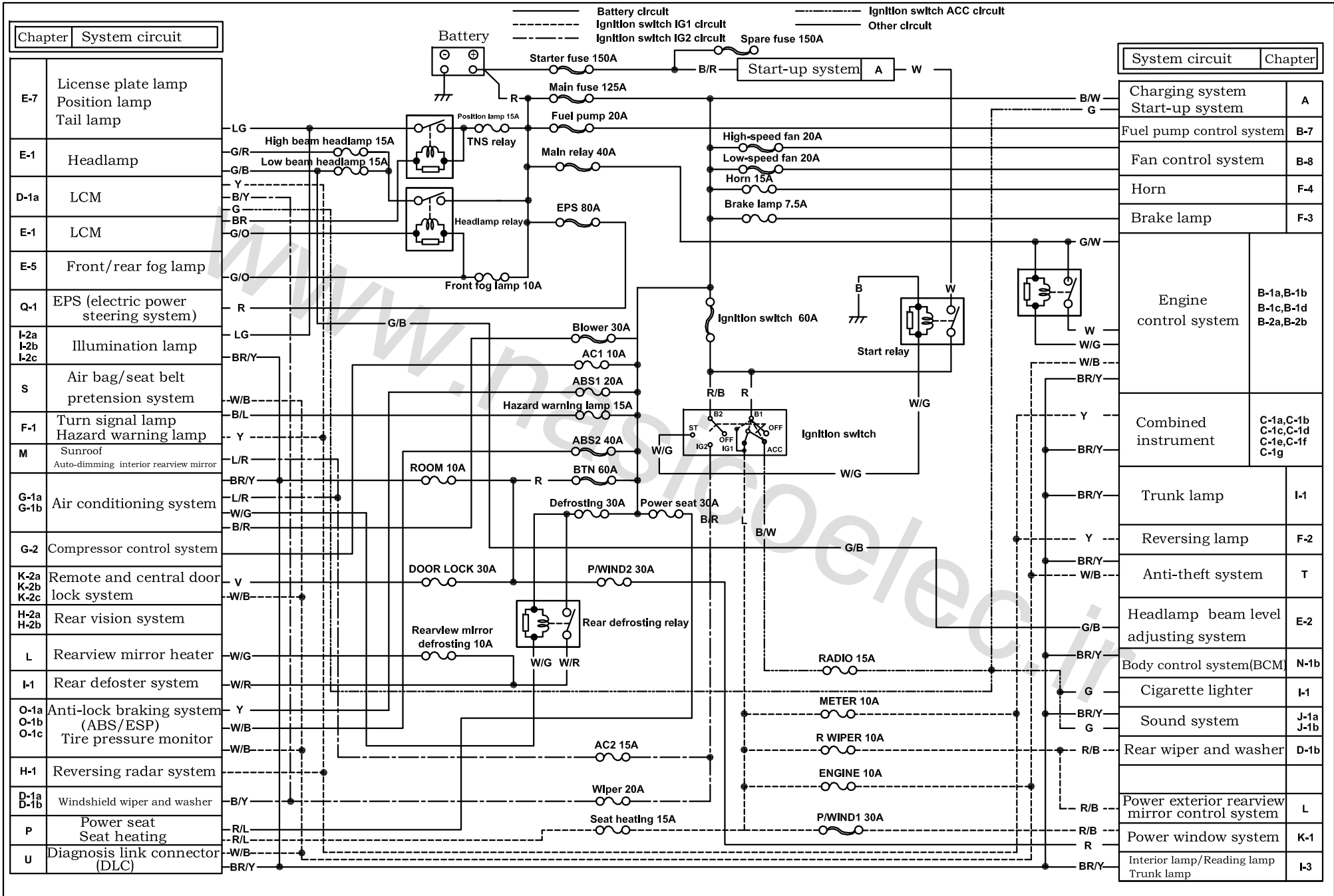

# Electric harness schematic (with smart key)

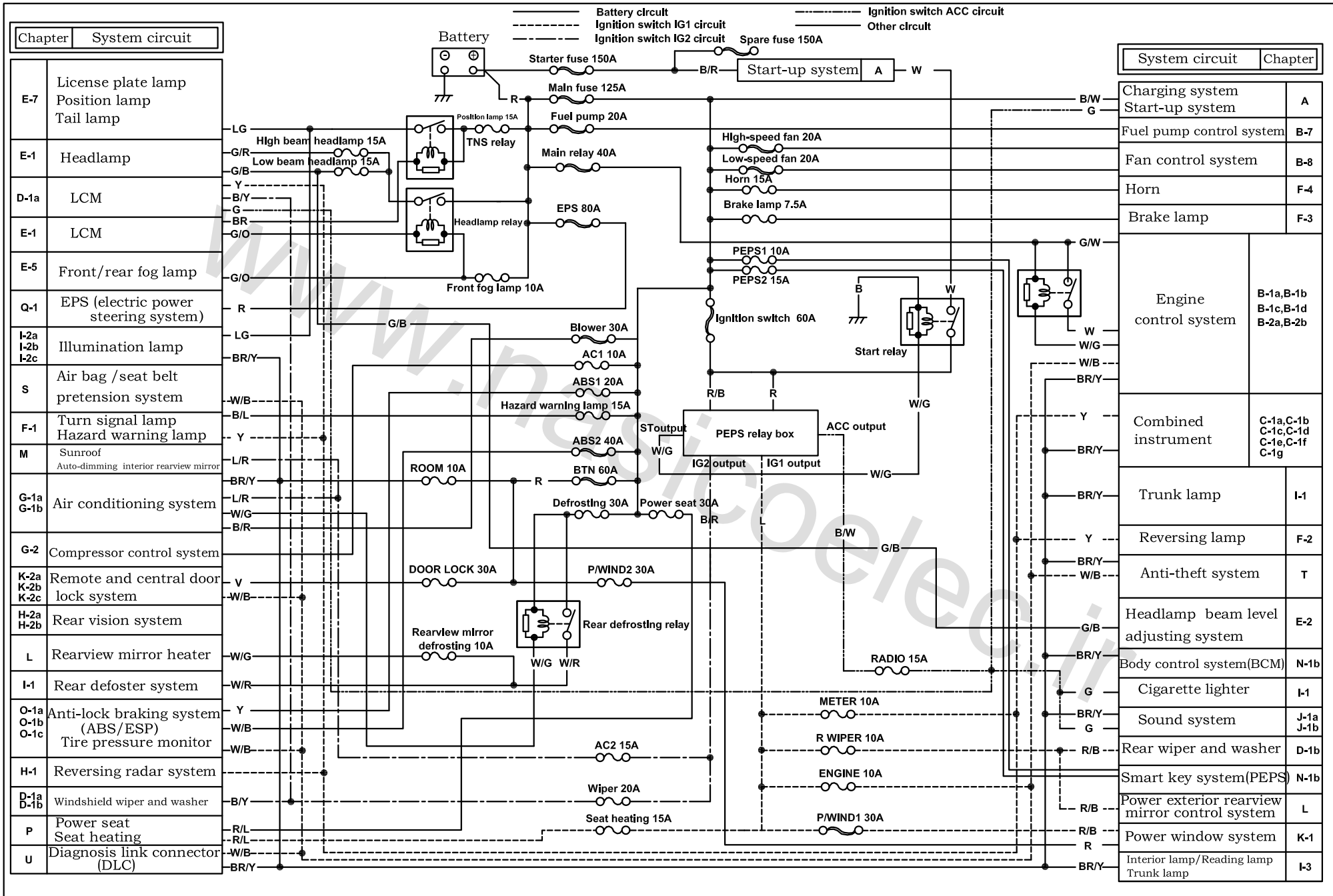

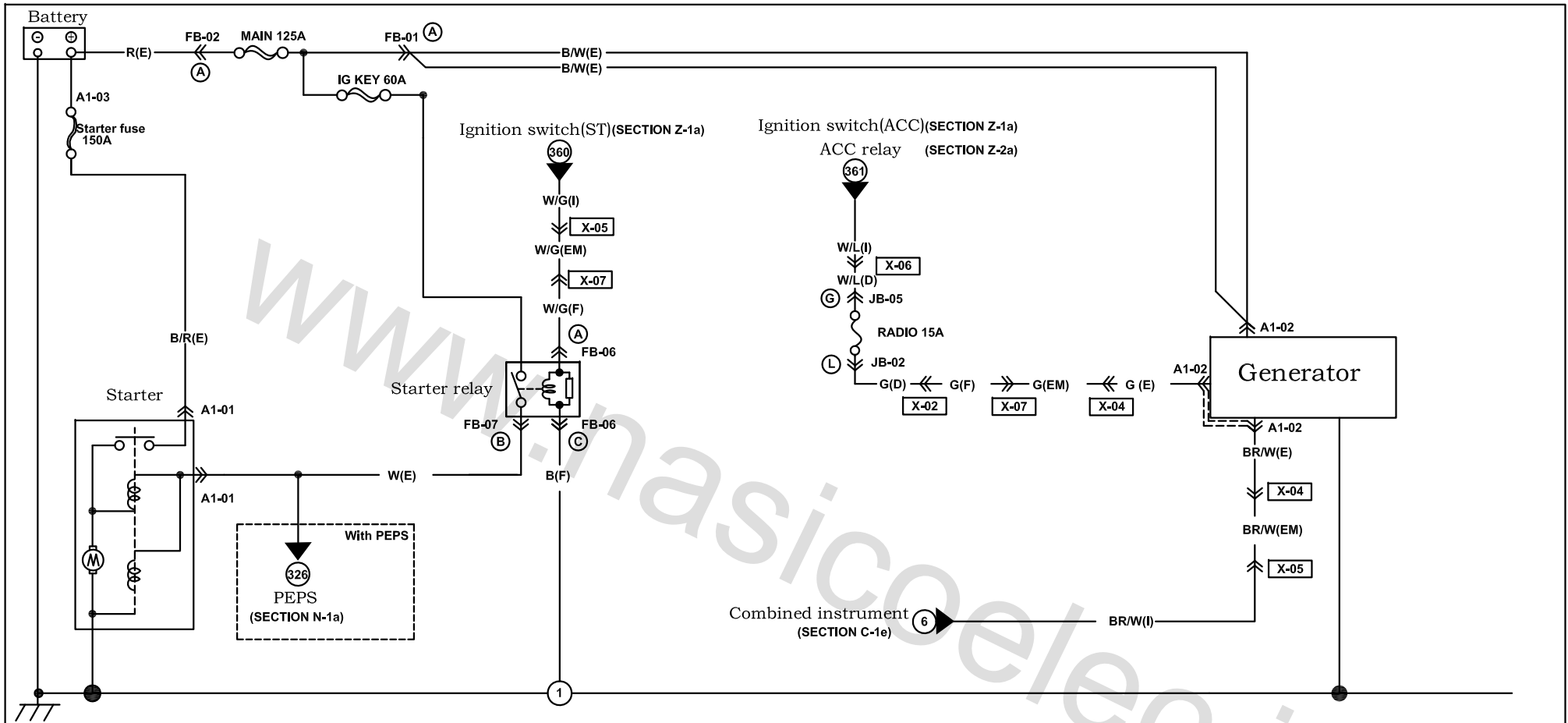

<p><b>A1-01 Starter (E)</b></p>	<p><b>A1-02 Generator (E)</b></p>	<p><b>A1-02 Generator (E)</b></p>	<p><b>A1-03 Battery B+ (E)</b></p>			



Harness mark:  (F)  (E)  (D)  (R)

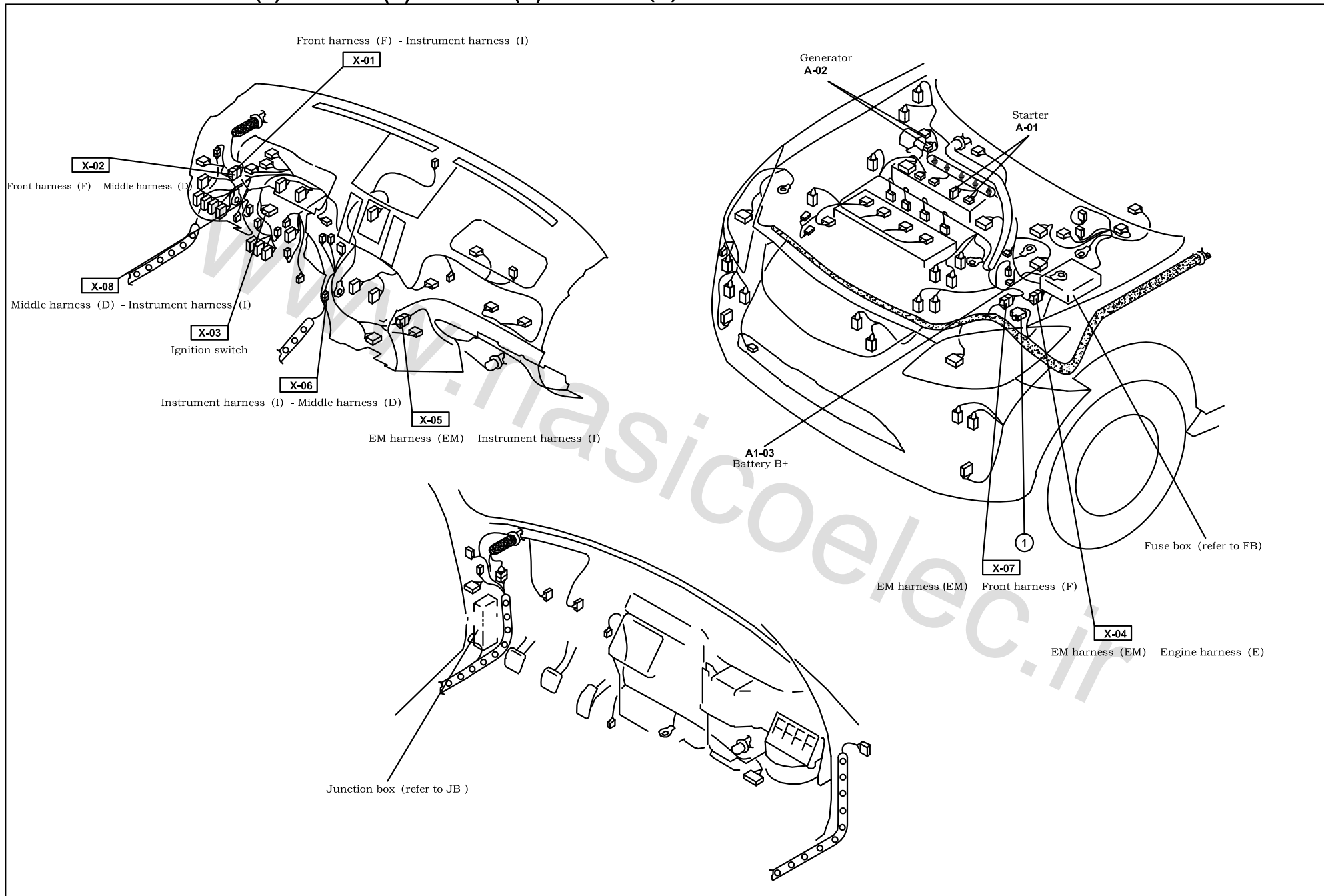

# Start-stop start-up system

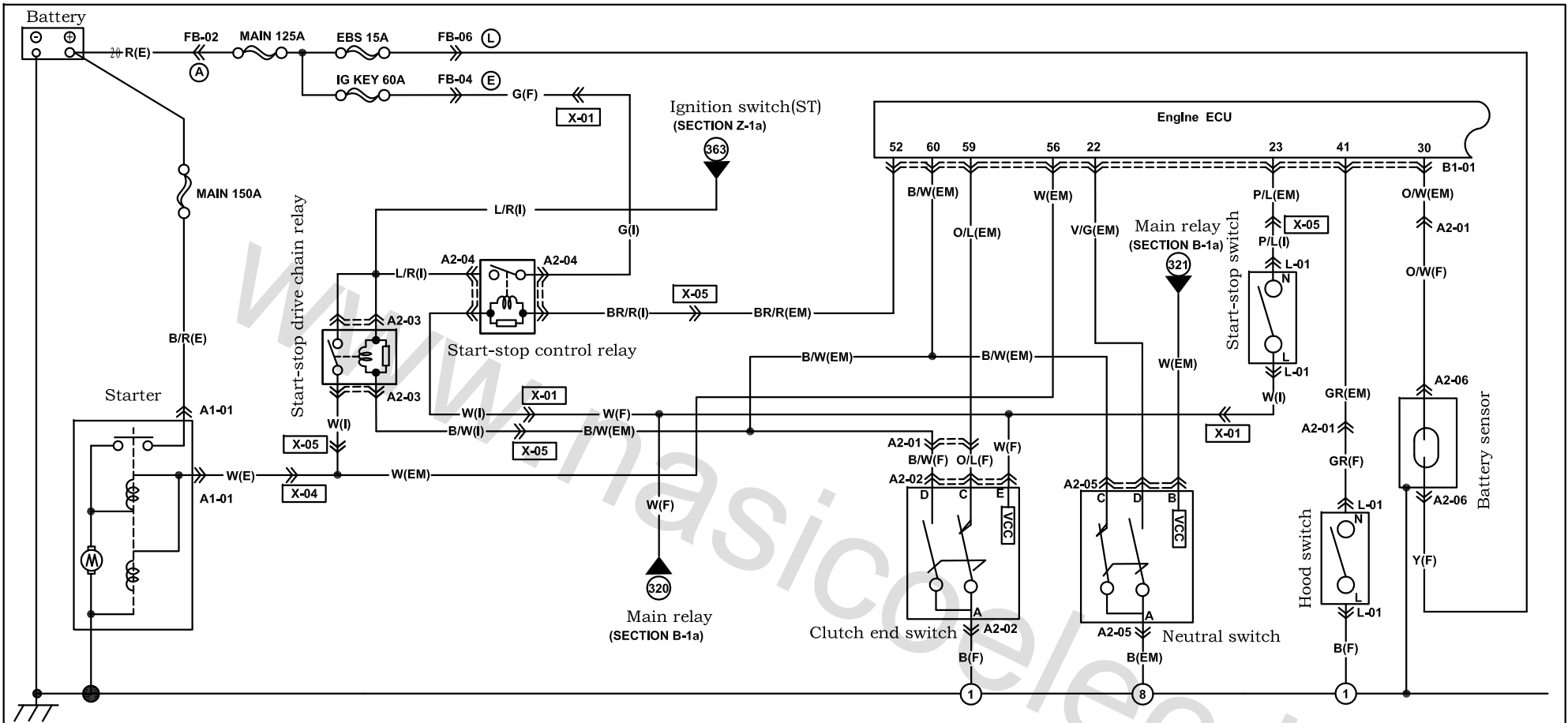

<p><b>A1-01 Starter (E)</b></p>	<p><b>A2-02 Clutch switch (EM)</b></p>	<p><b>A2-03 Start-stop drive chain relay (EM)</b></p>	<p><b>A2-04 Start-stop control relay (EM)</b></p>	<p><b>A2-05 Neutral switch (EM)</b></p>	<p><b>A2-06 Battery sensor (F)</b></p>																																								
<p><b>A2-01 Start-stop connector (EM)</b></p>	<p><b>A2-07 Hood switch (F)</b></p>	<p><b>L-01 Integrated Switch (I) &lt;&gt; with start-stop</b></p> <table border="1"> <tr> <td>S</td><td>Q</td><td>O</td><td>M</td><td>K</td><td>I</td><td>G</td><td>E</td><td>C</td><td>A</td> </tr> <tr> <td>R/B</td><td>LG</td><td>LG/B</td><td>L/W</td><td>L</td><td>L/O</td><td>L/B</td><td>V</td><td>R/G</td><td>R/Y</td> </tr> <tr> <td>B</td><td>P</td><td>G/B</td><td>* &lt;P/L&gt;</td><td>W</td><td>*</td><td>*</td><td>*</td><td>*</td><td>B</td> </tr> <tr> <td>T</td><td>R</td><td>P</td><td>N</td><td>L</td><td>J</td><td>H</td><td>F</td><td>D</td><td>B</td> </tr> </table>				S	Q	O	M	K	I	G	E	C	A	R/B	LG	LG/B	L/W	L	L/O	L/B	V	R/G	R/Y	B	P	G/B	* <P/L>	W	*	*	*	*	B	T	R	P	N	L	J	H	F	D	B
S	Q	O	M	K	I	G	E	C	A																																				
R/B	LG	LG/B	L/W	L	L/O	L/B	V	R/G	R/Y																																				
B	P	G/B	* <P/L>	W	*	*	*	*	B																																				
T	R	P	N	L	J	H	F	D	B																																				

Harness mark:  (F)  (E)  (D)  (R)

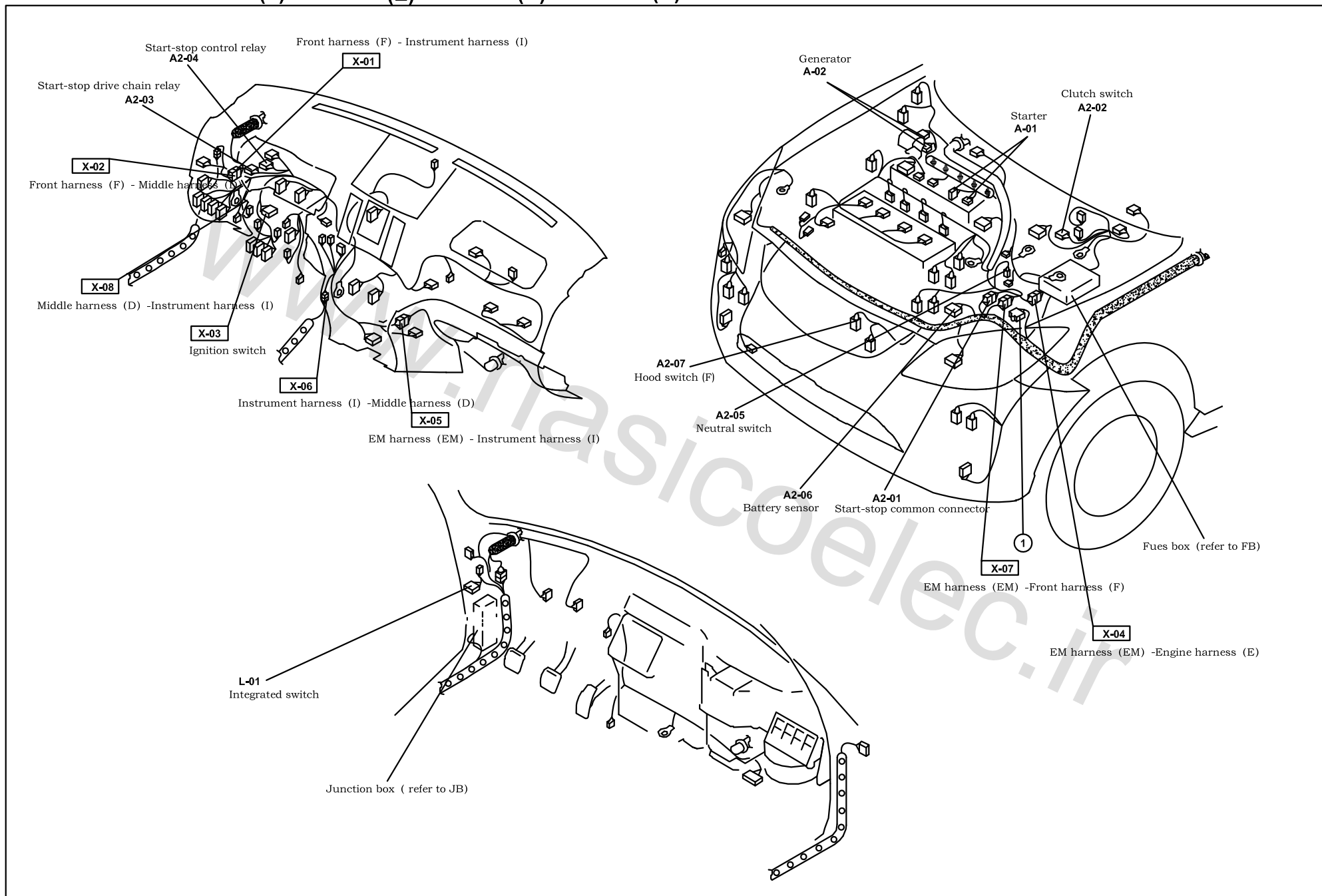

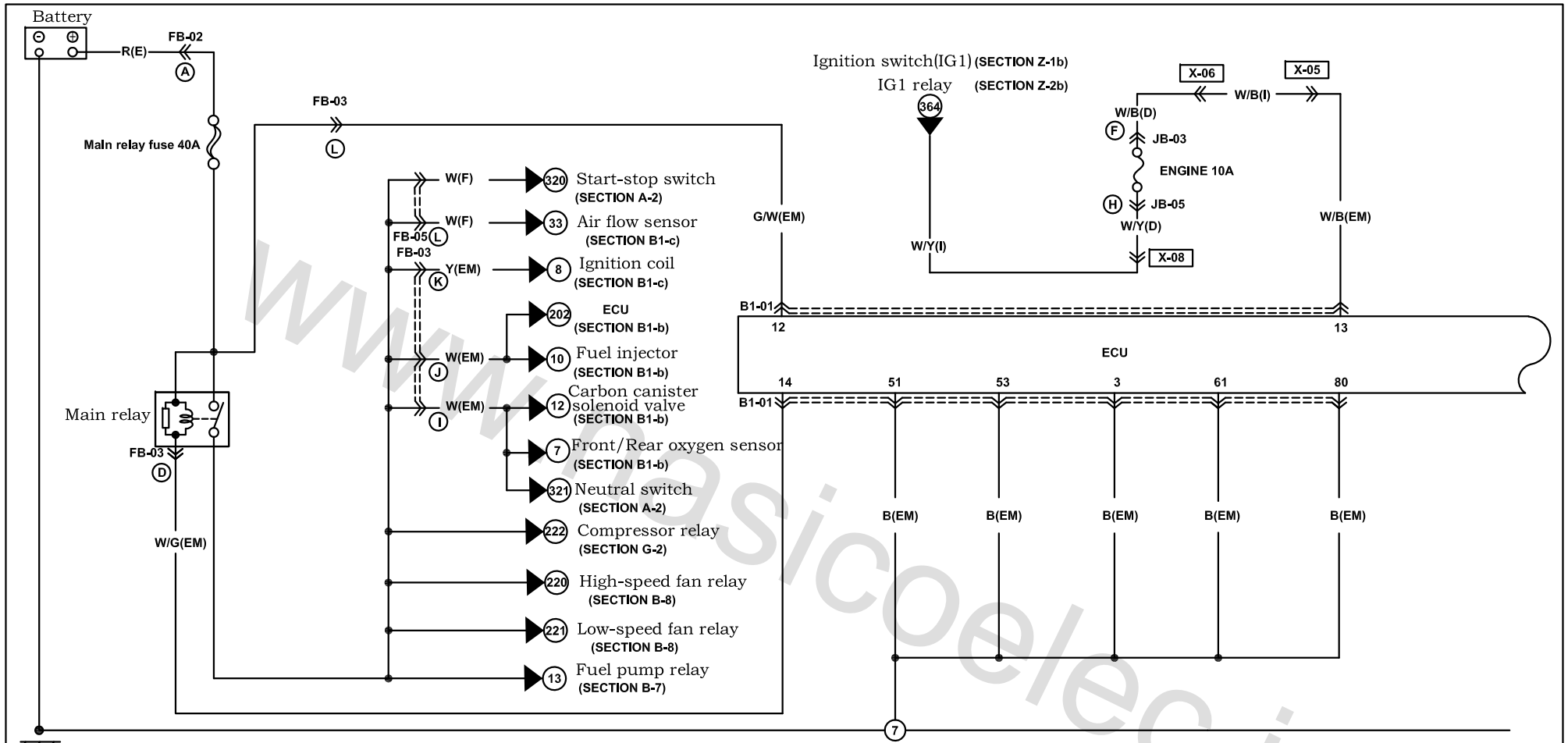

B1-01 ECU(EM)

< > AT model  
& Start-stop model

63	W	B/R	B/R	G/L	G/L	LG	BR/Y	W/R	G/B	Y/G	Y	Y/L	G	*	&Y/R	P	W/L	B	L/O	81
	W	W	B/O	R/L	Y/G	*	L/R	B	B/R	B	V	O	&W	LG/R	B/L	&O/L	&B/W	B	B/G	62
44																				
25	*	R/G	R/B	G/W	Y/L	&O/W	*	Y	B/W	Y/G	Y/L	B/R	BR	P/L	L	B/Y	&G/R	V/W	&P/G	43
	R/W	R/Y	GR/L	*	*	&GR/R	G/W	W/B	W/G	W/R	GR	LG/B	R/W	L/B	L/W	R/G	&V/G	*	*	24
6																				

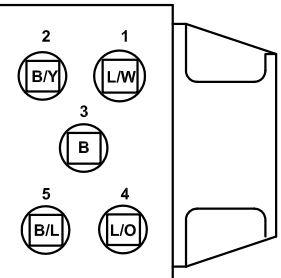

Harness mark:  (F)  (E)  (D)  (R)

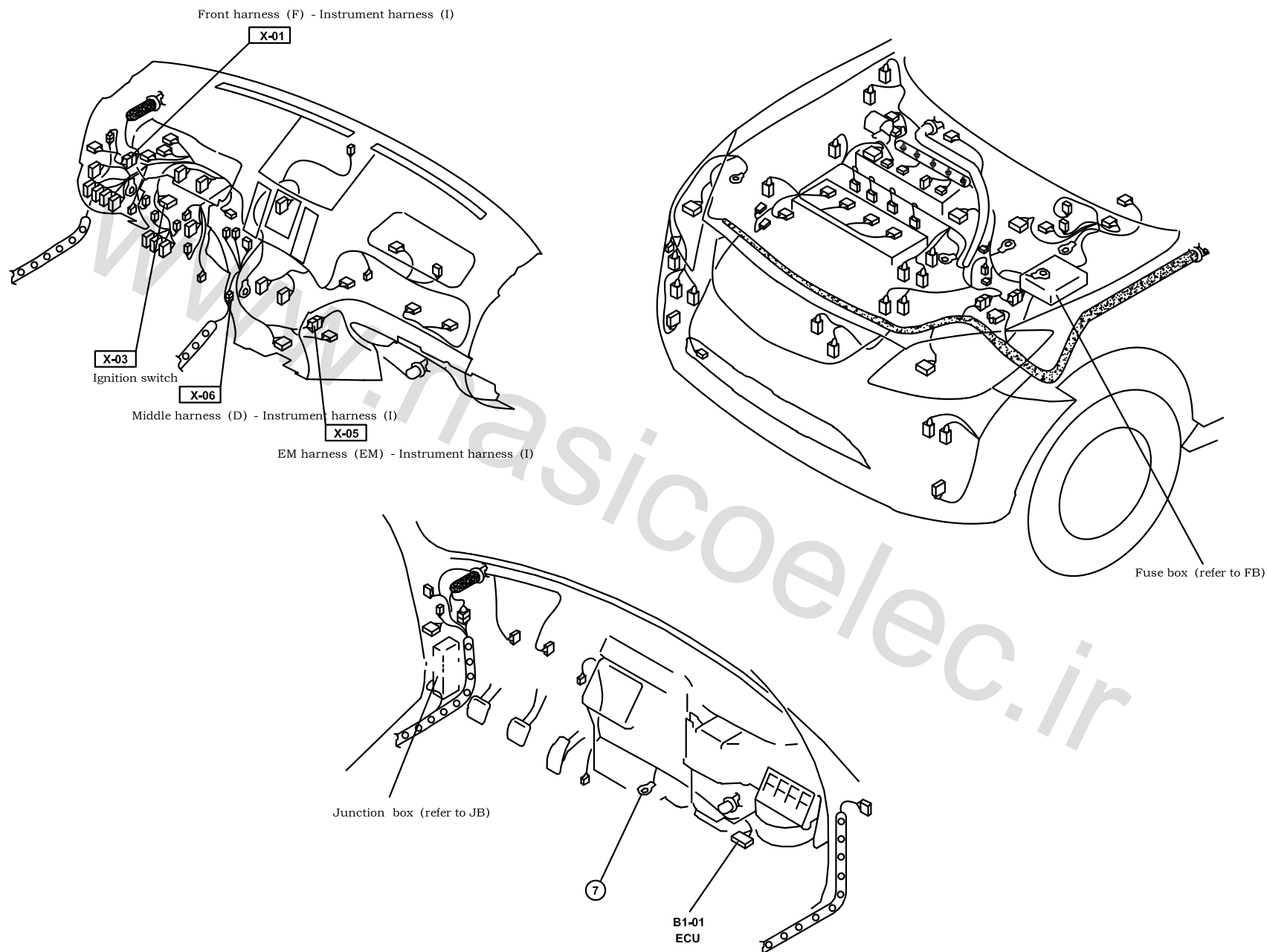

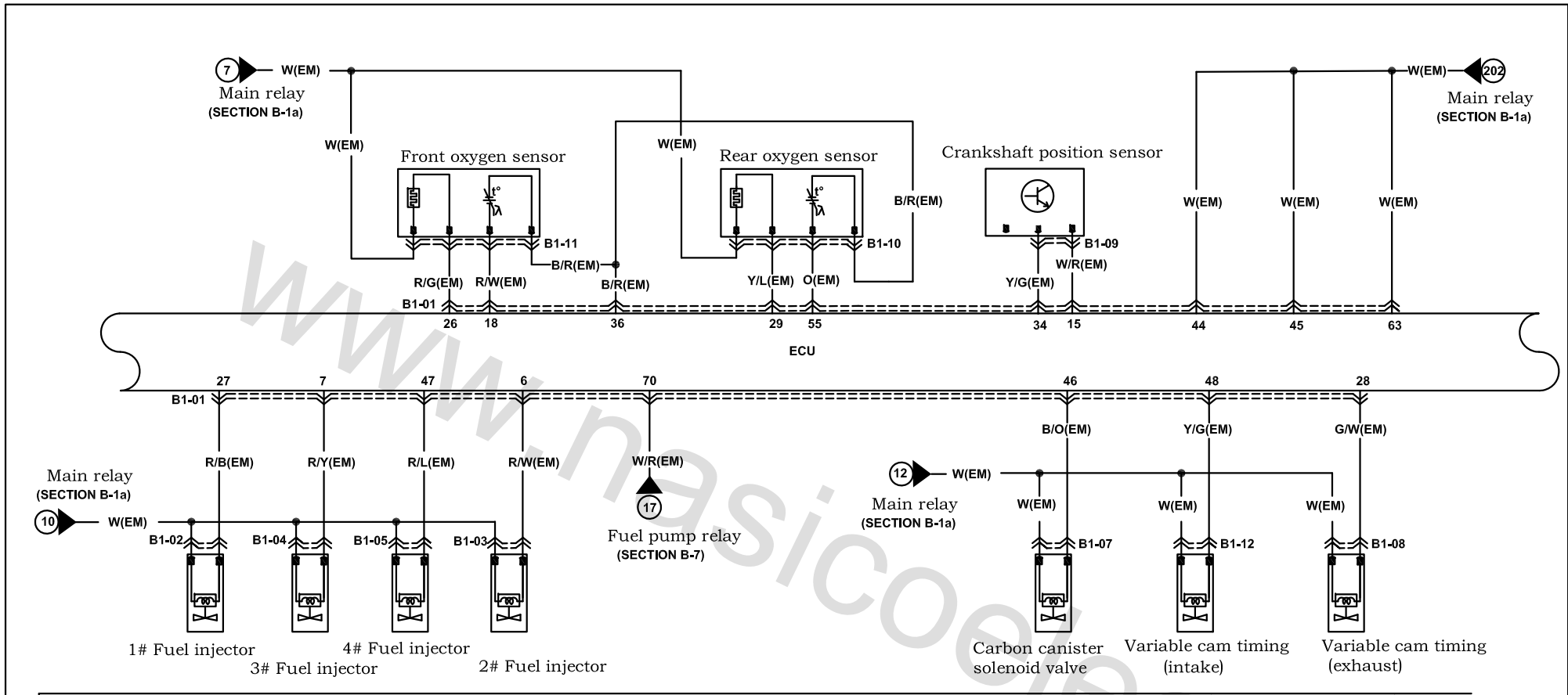



777

B1-01 ECU(EM)

<> AT Model & Start-stop model

63	W	B/R	B/R	G/L	G/L	LG	BR/Y	W/R	G/B	Y/G	Y	Y/L	G	*	&Y/R	P	W/L	B	L/O	81
	W	W	B/O	R/L	Y/G	*	L/R	B	&B/R	B	V	O	&W	LG/R	B/L	&O/L	&B/W	B	B/G	62
44																				62
25	*	R/G	R/B	G/W	Y/L	&O/W	*	Y	B/W	Y/G	Y/L	B/R	BR	P/L	L	B/Y	&G/R	V/W	&P/G	43
	R/W	R/Y	GR/L	*	*	&GR/R	G/W	W/B	W/G	W/R	GR	LG/B	R/W	L/B	L/W	R/G	&V/G	*	*	24
6																				24

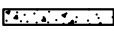
<b>B1-02</b> 1# Fuel injector(EM)	<b>B1-03</b> 2# Fuel injector(EM)	<b>B1-04</b> 3# Fuel injector(EM)	<b>B1-05</b> 4# Fuel injector(EM)
<b>B1-07</b> Carbon canister solenoid valve(EM)	<b>B1-08</b> Variable cam timing(EM)	<b>B1-09</b> Crankshaft position sensor(EM)	
<b>B1-10</b> Rear oxygen sensor(EM)	<b>B1-11</b> Front oxygen sensor(EM)	<b>B1-12</b> Variable cam timing (EM)	

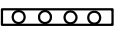
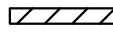
Harness mark:  (F)  (E)  (D)  (R)

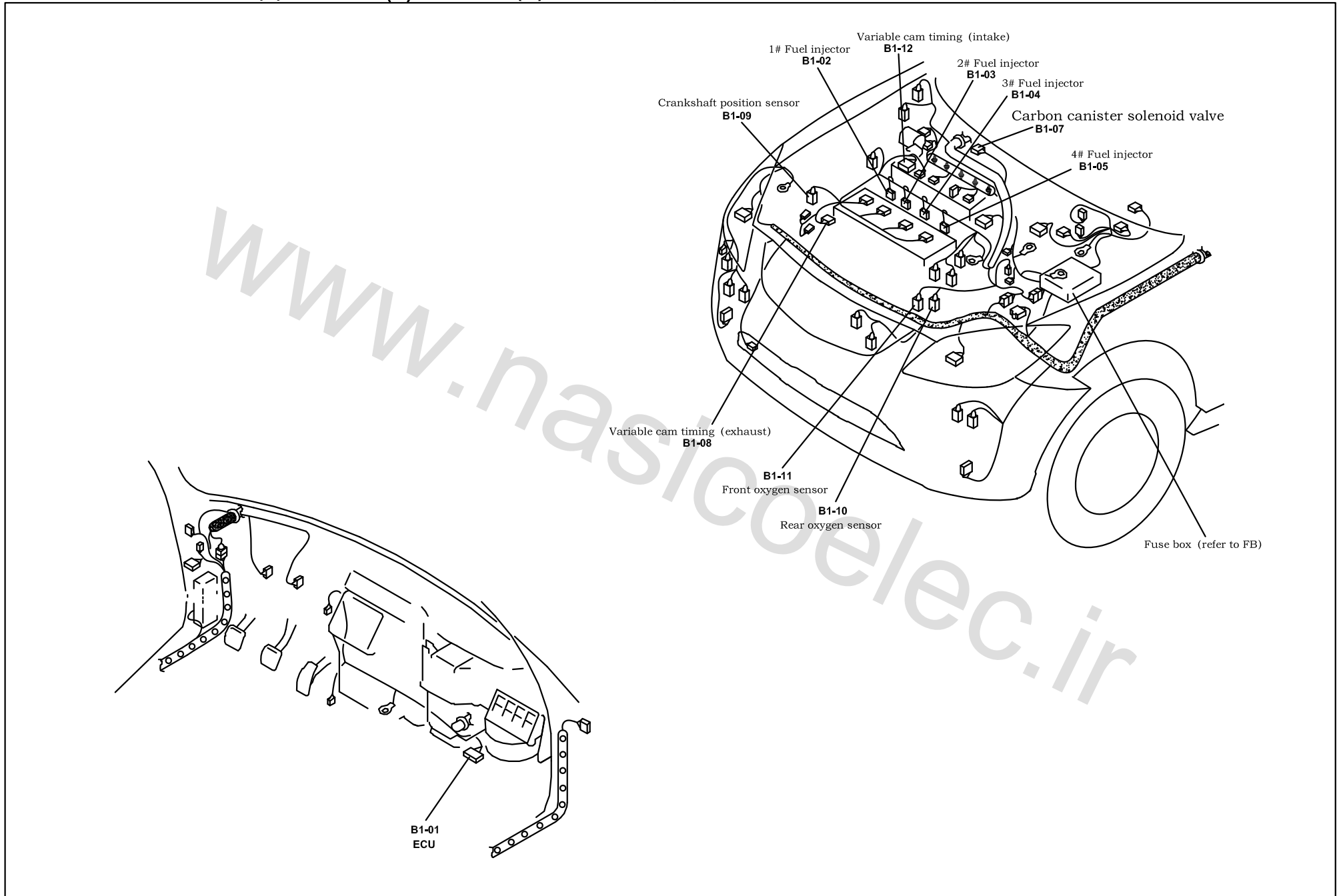

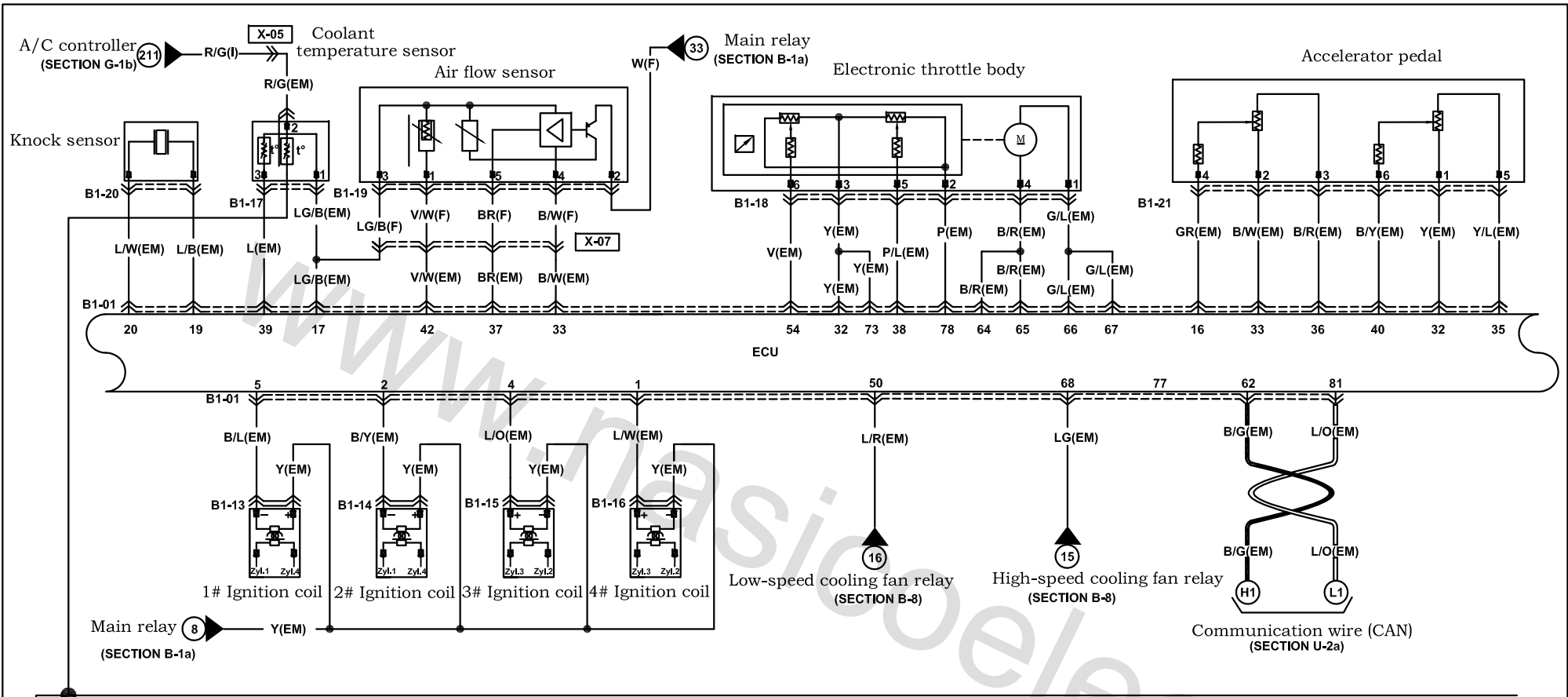

B1-01 ECU(EM)

<> AT Model & Start-stop model

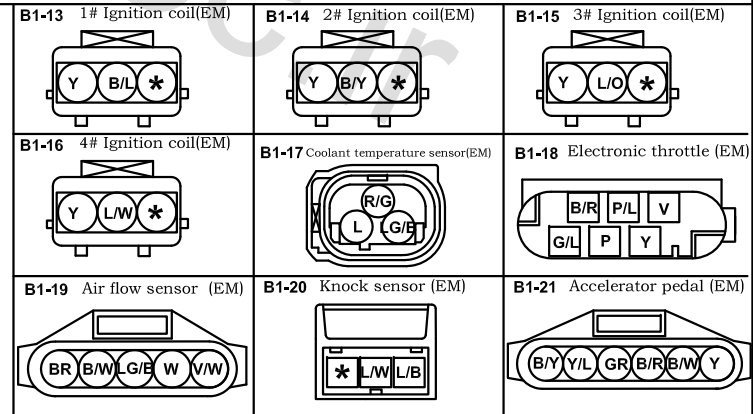

63	W	B/R	B/R	G/L	G/L	LG	BR/Y	W/R	G/B	Y/G	Y	Y/L	G	*	&Y/R	P	W/L	B	L/O	81
	W	W	B/O	R/L	Y/G	*	L/R	B	&B/R	B	V	O	&W	LG/R	B/L	&O/L&B/W	B	B/G		62
44																				
25	*	R/G	R/B	G/W	Y/L	&Q/W	*	Y	B/W	Y/G	Y/L	B/R	BR	P/L	L	B/Y	&G/R	V/W	&P/G	
	R/W	R/Y	GR/L	*	*	&GR/R	G/W	W/B	W/G	W/R	GR	LG/B	R/W	L/B	L/W	R/G	&V/G	*	*	
6																				24

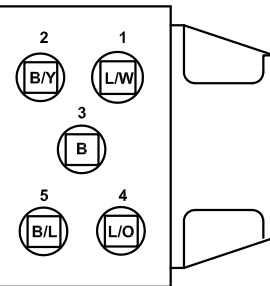



Harness mark:  (F)  (E)  (D)  (R)

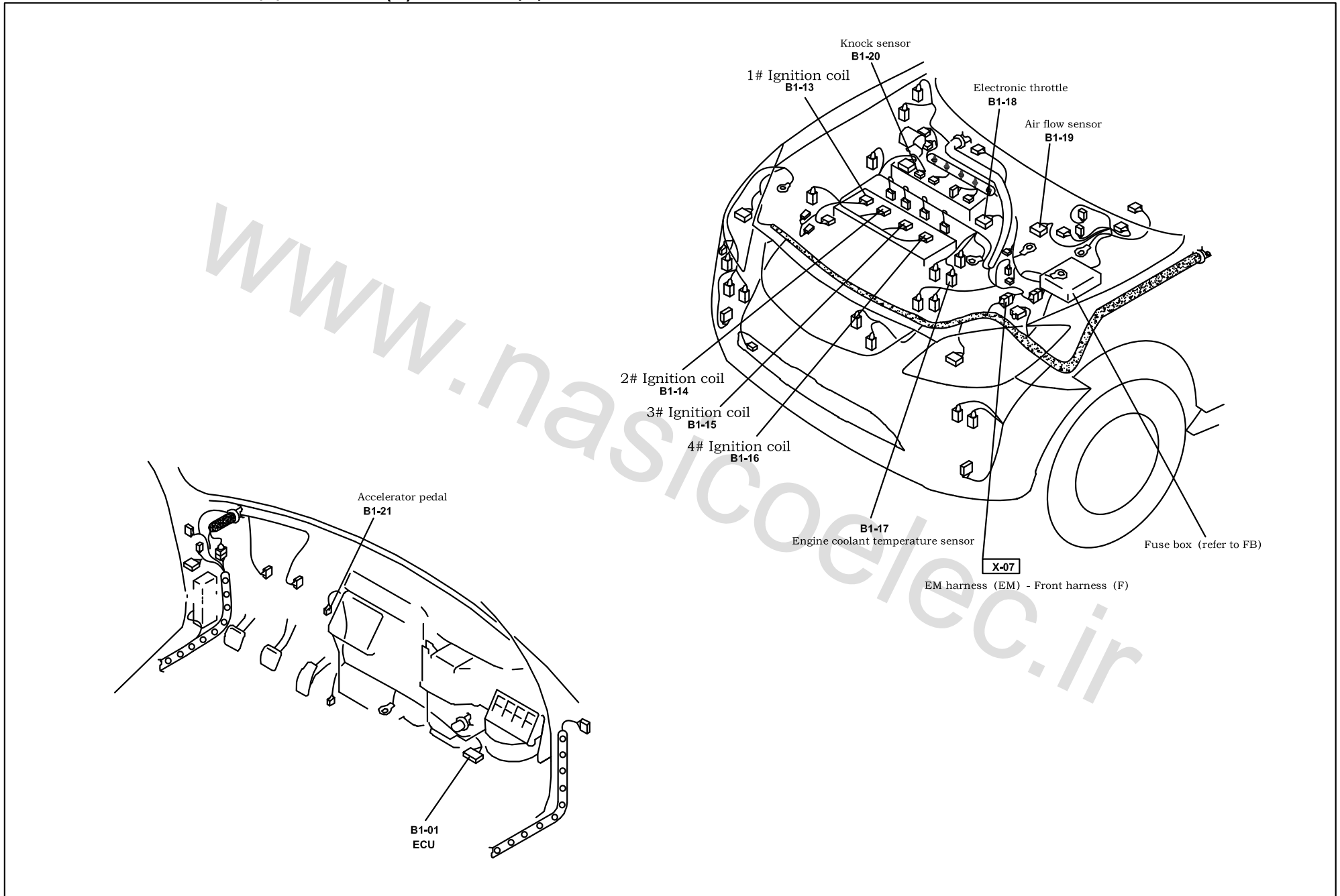

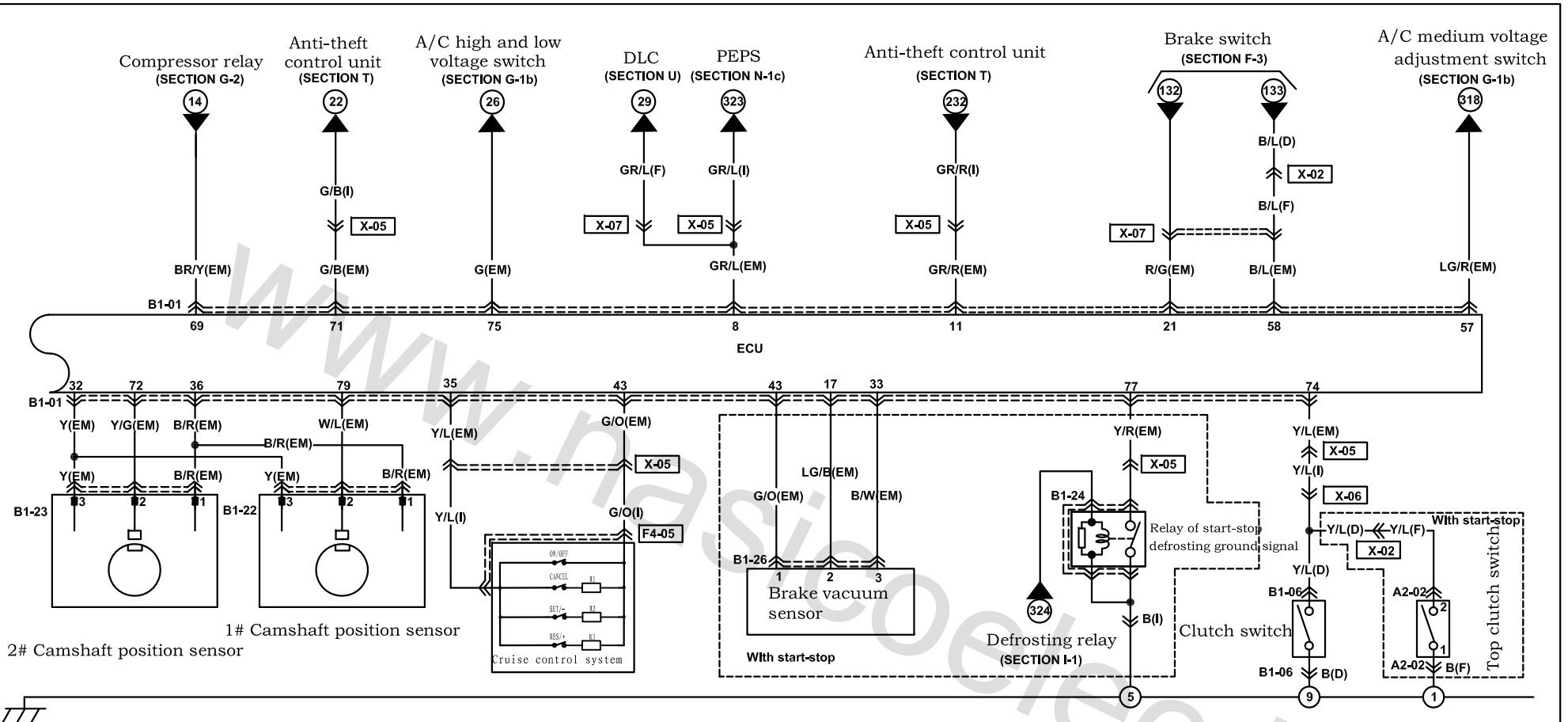

**B1-01 ECU(EM)**

< > AT Model & Start-stop model

63	W	B/R	B/R	G/L	G/L	LG	BR/Y	W/R	G/B	Y/G	Y	Y/L	G	*	&Y/R	P	W/L	B	L/O	81
	W	W	B/O	R/L	Y/G	*	L/R	B	&B/R	B	V	O	&W	LG/R	B/L	&O/L	&B/W	B	B/G	62
44																				62
25	*	R/G	R/B	G/W	Y/L	&Q/W	*	Y	B/W	Y/G	Y/L	B/R	BR	P/L	L	B/Y	&G/R	V/W	&P/G	43
	R/W	R/Y	GR/L	*	*	&GR/F	G/W	W/B	W/G	W/R	GR	LG/B	R/W	L/B	L/W	R/G	&V/G	*	*	24
6																				24

2

1

3

4

5

**B1-22**  
1# Camshaft position sensor(EM)

**B1-23**  
2# Camshaft position sensor(EM)

**F4-05** Clock spring (I) [ ] With cruise

**B1-26**  
Brake vacuum sensor (EM)

**B1-06**  
Clutch switch (EM)

**B1-24** Relay of start-stop defrosting ground signal(I)

**A2-02** Clutch switch (EM)

E D C B A

Harness mark:  (F)  (E)  (D)  (R)

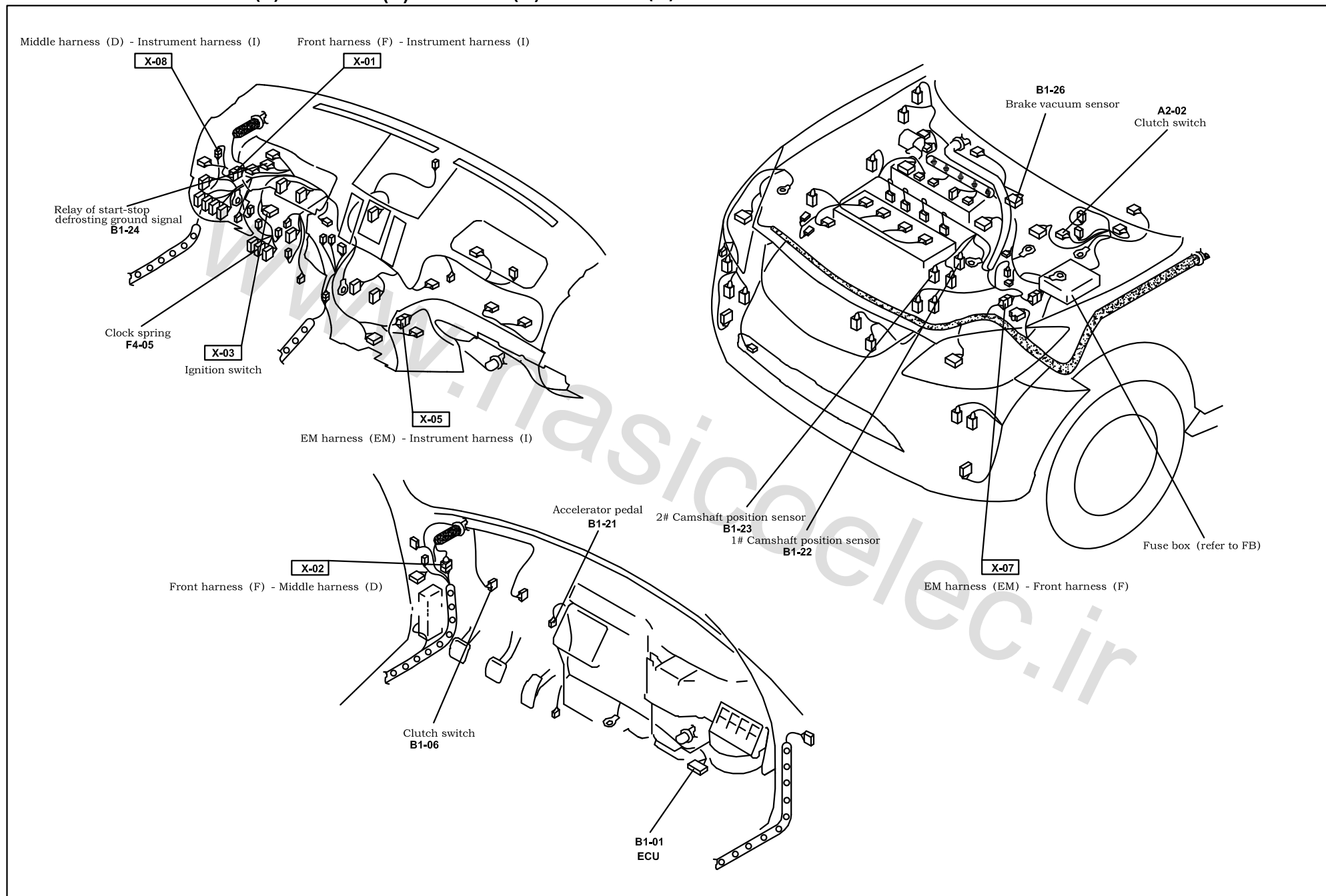

# Transmission control system (AT)

B-2a

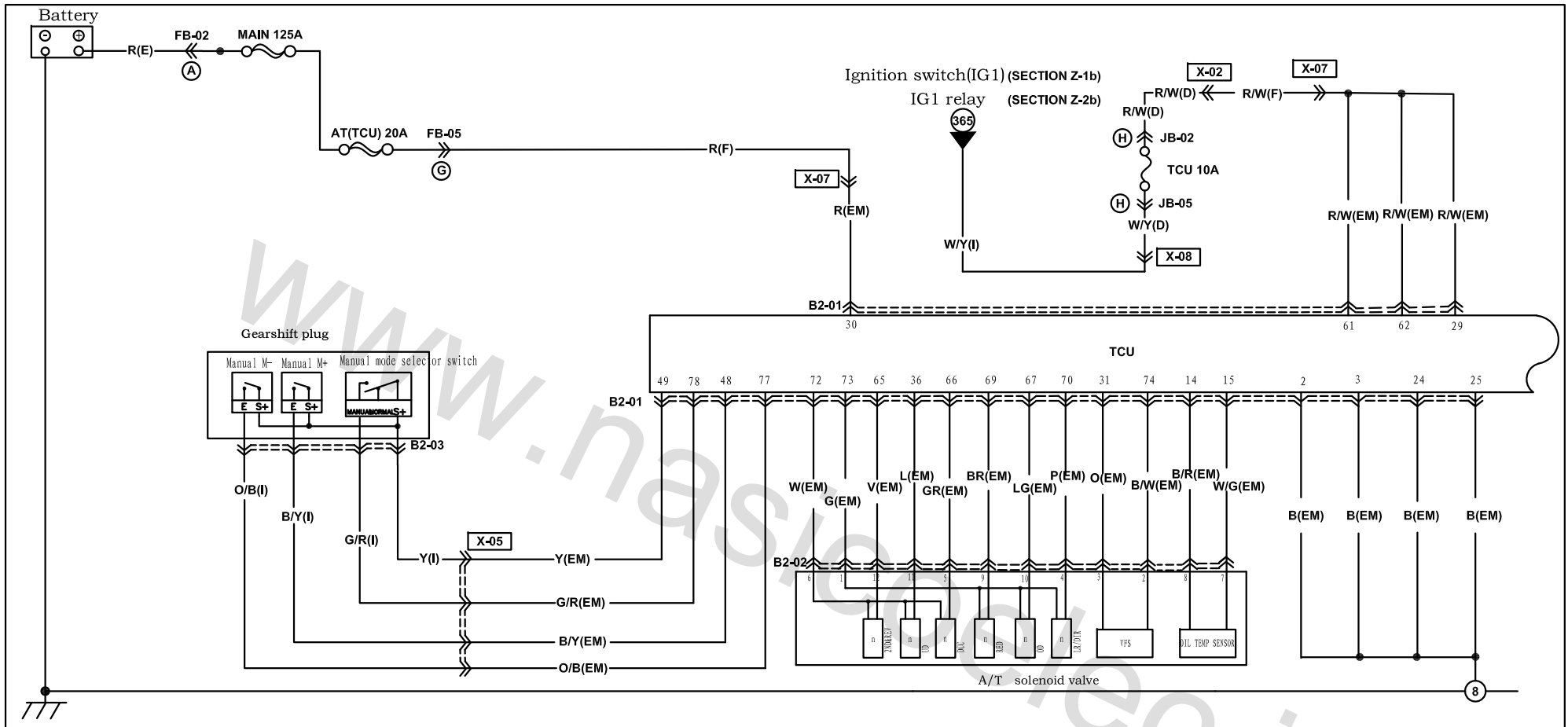

B2-01 TCU(EM)

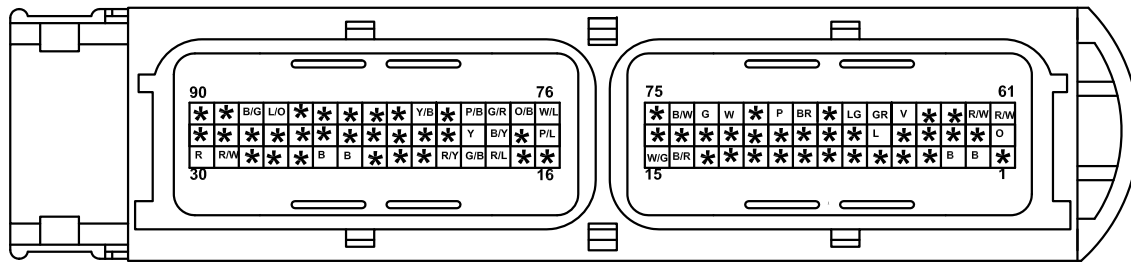

B2-02 A/T solenoid valve (EM)

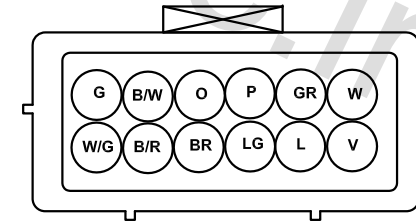

B2-03 Gearshift plug (I)



Harness mark:  (F)  (E)  (D)  (R)

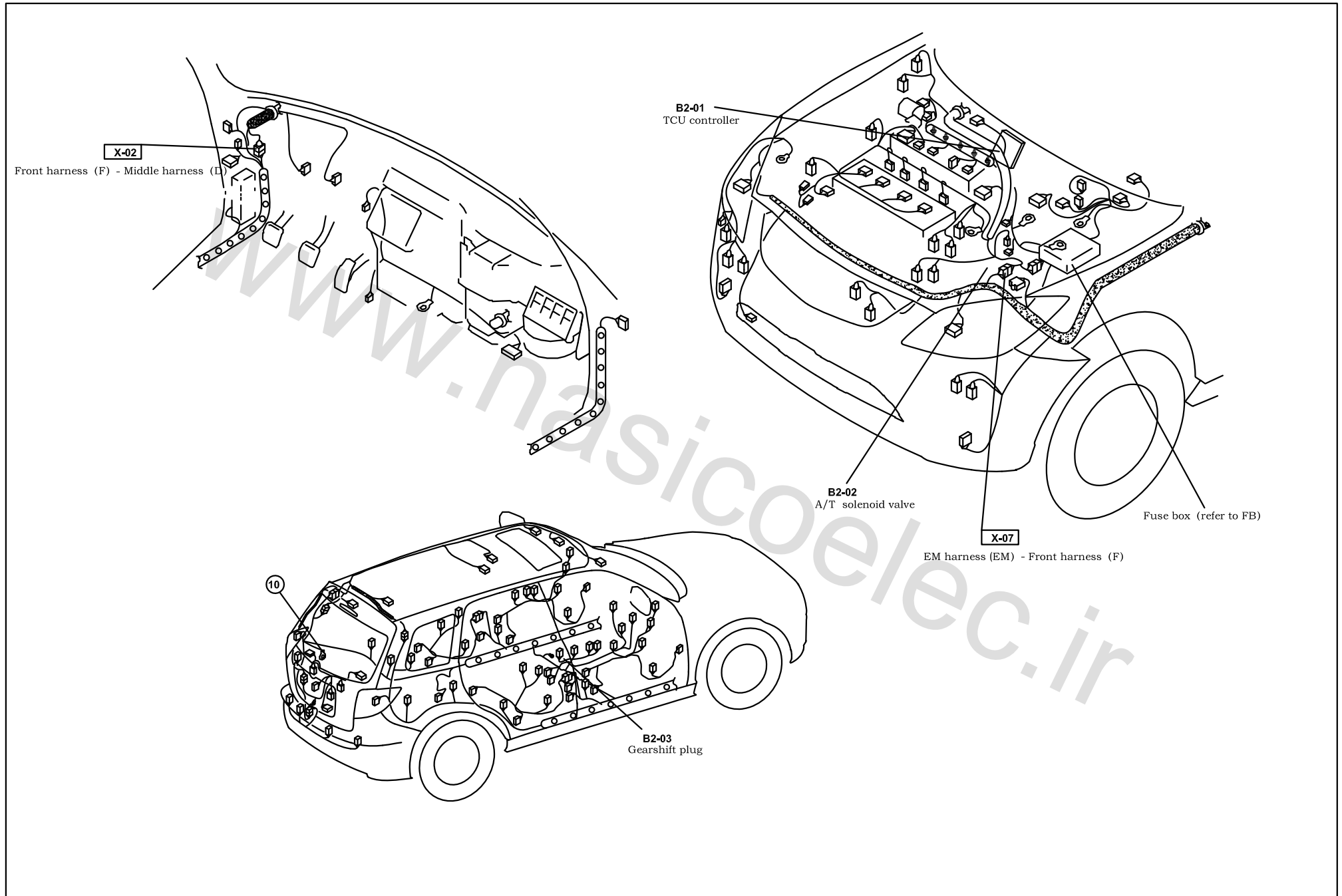

# Transmission control system (AT)

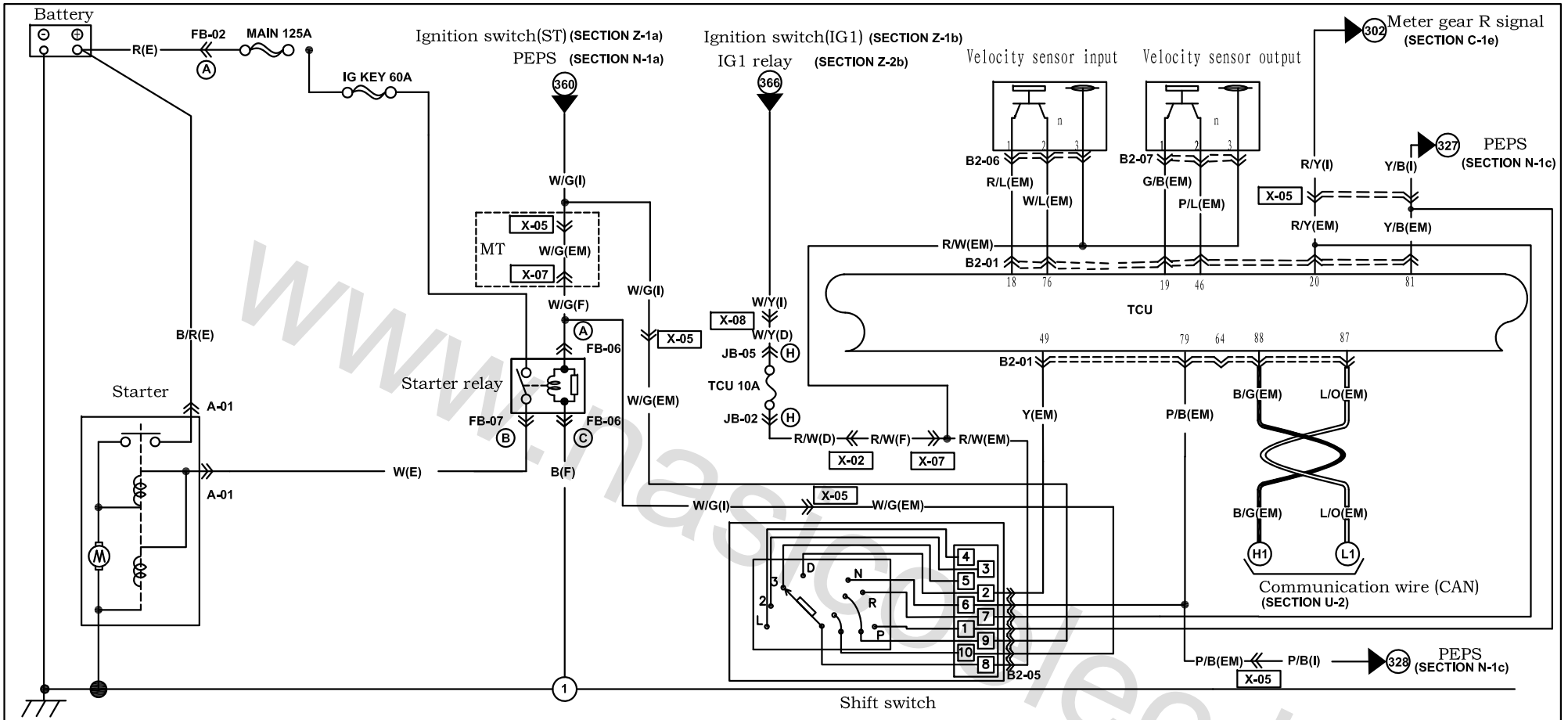

B2-01 TCU(EM)

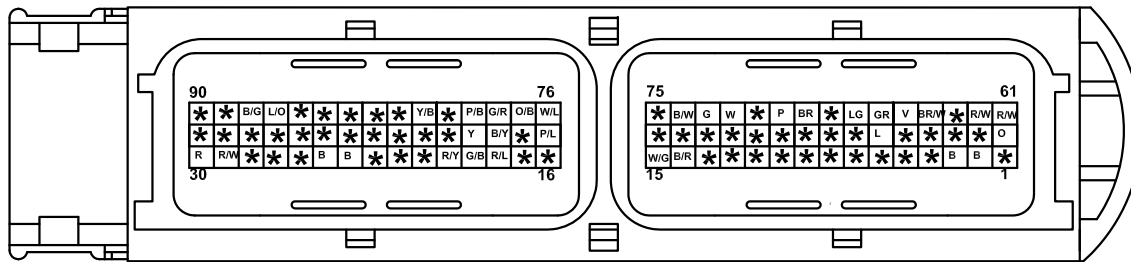

B2-05 Shift switch (EM)

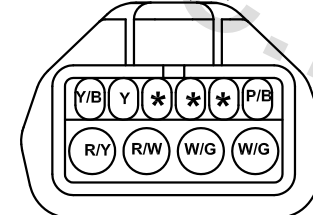

B2-06 Velocity sensor input (EM)

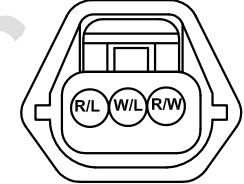

B2-07 Velocity sensor output (EM)

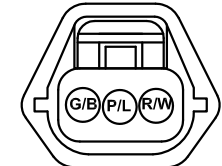

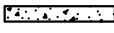
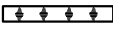
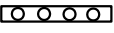
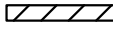

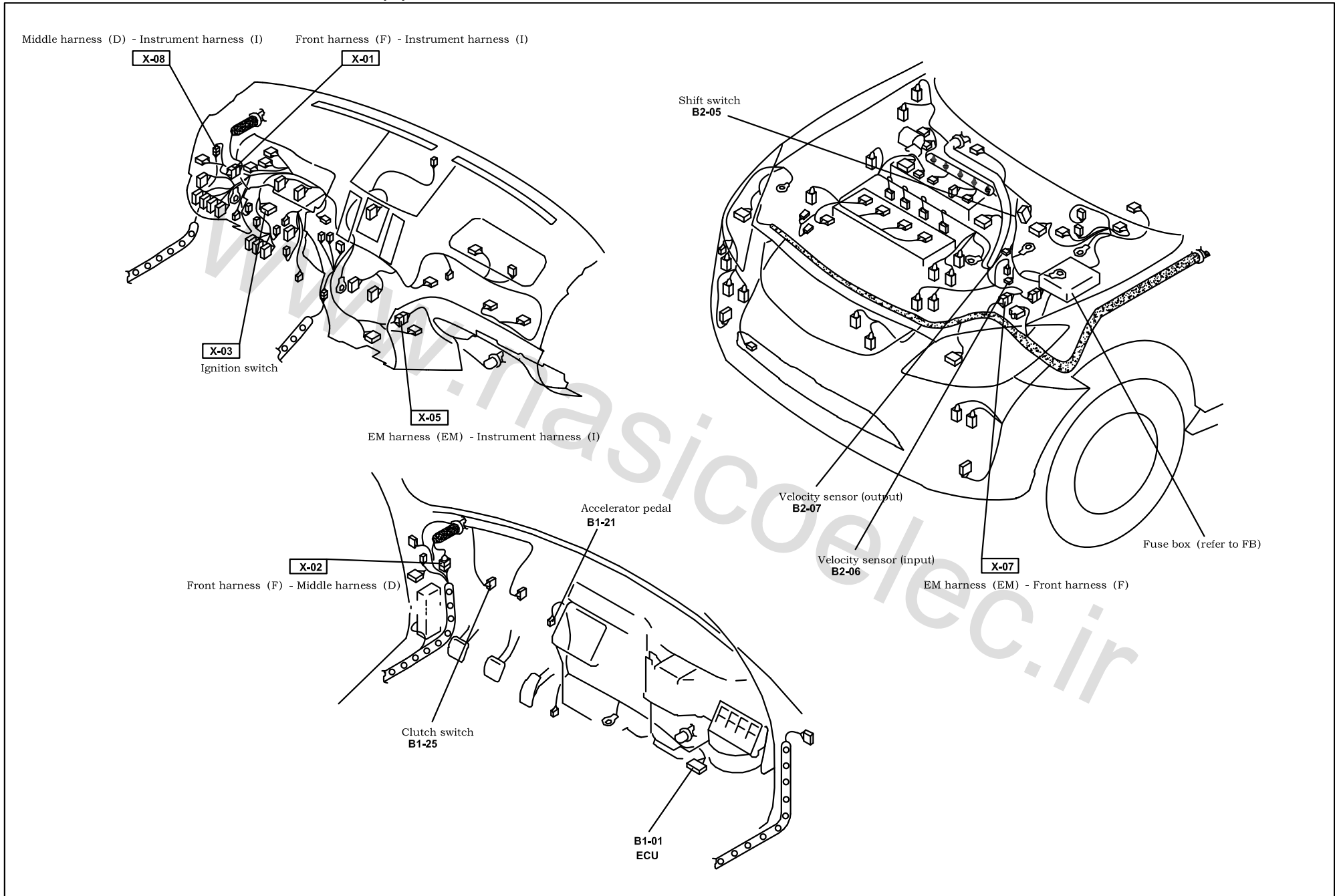
Harness mark:  (F)  (E)  (D)  (R)

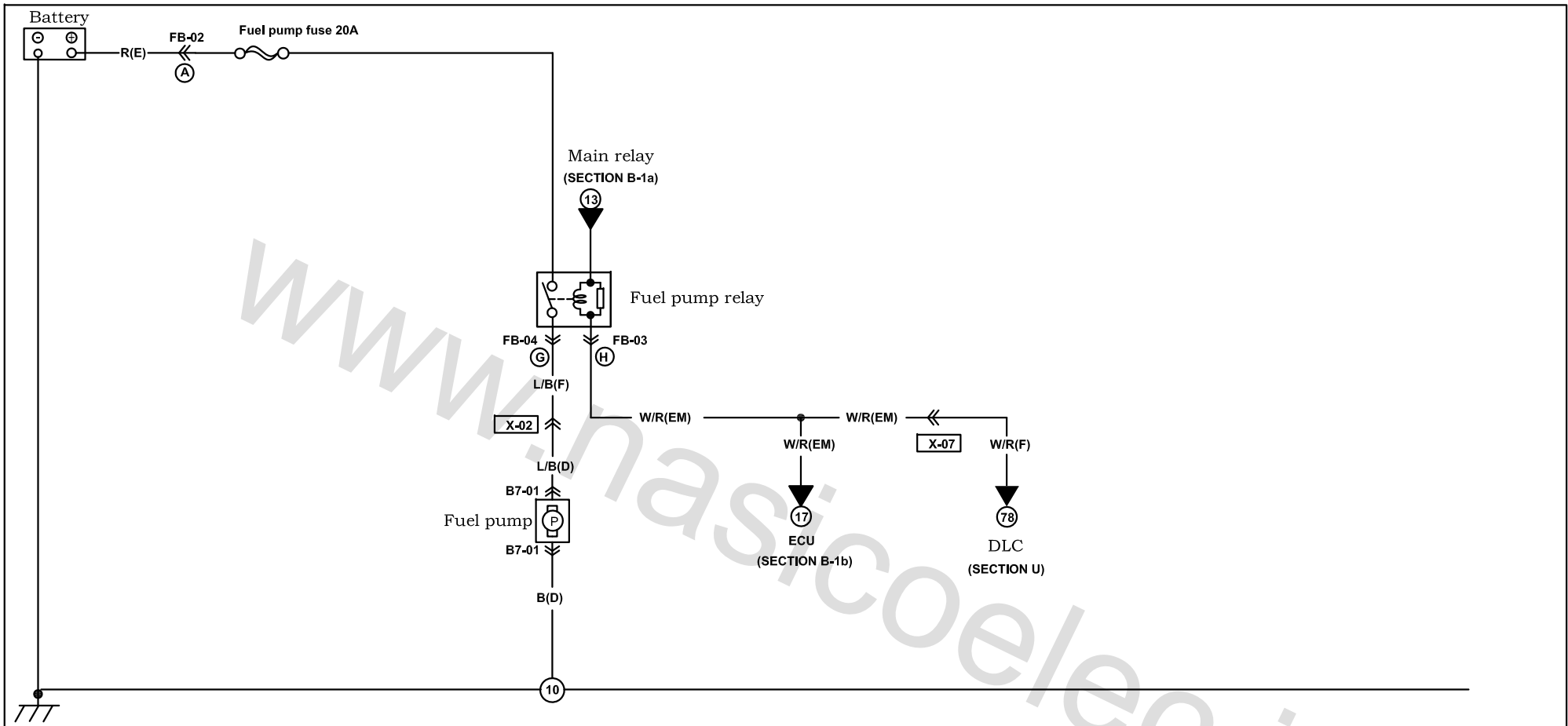

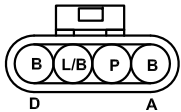

<p><b>B7-01</b> Fuel pump (D)</p> 					

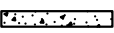

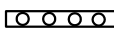
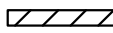

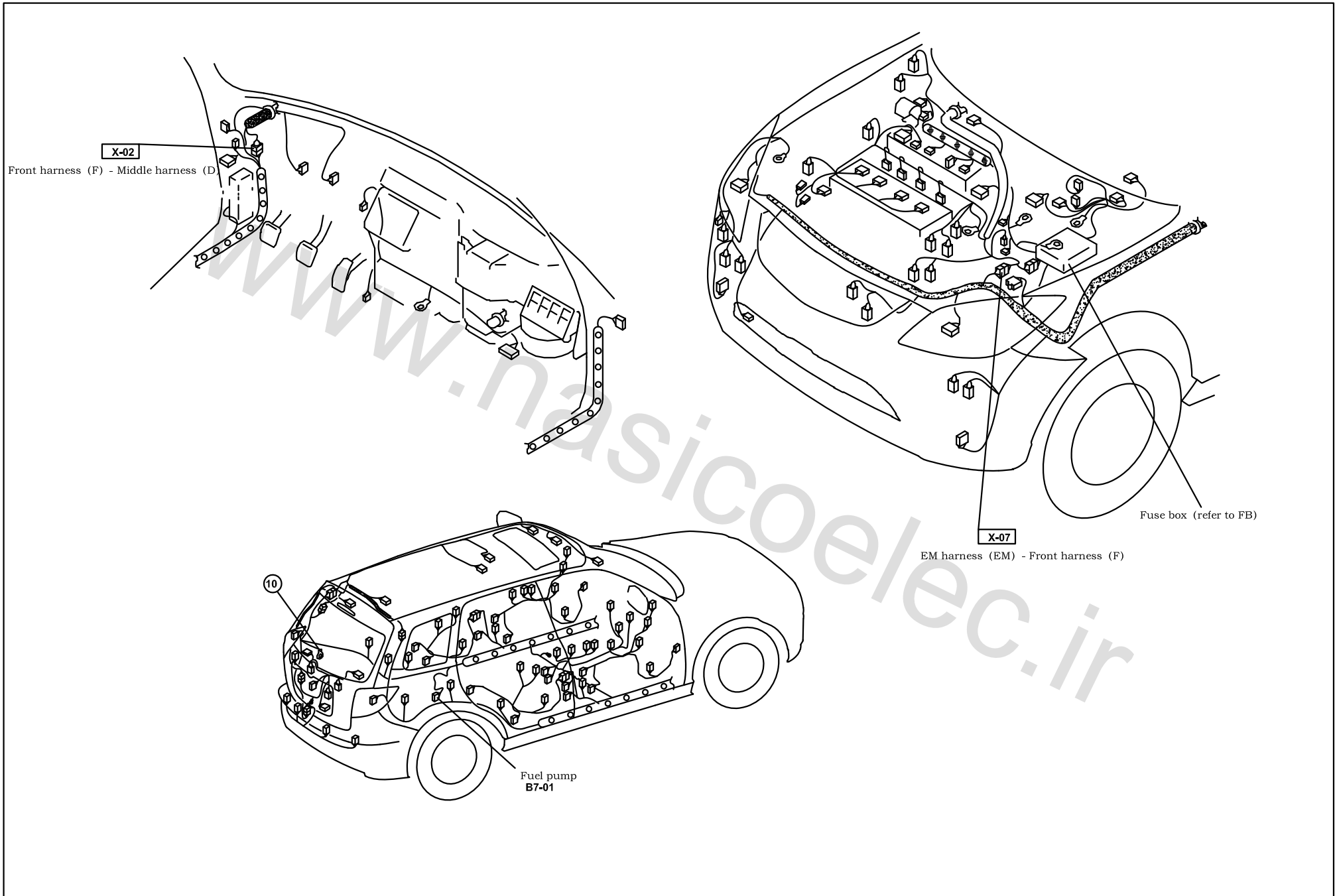
Harness mark:  (F)  (E)  (D)  (R)

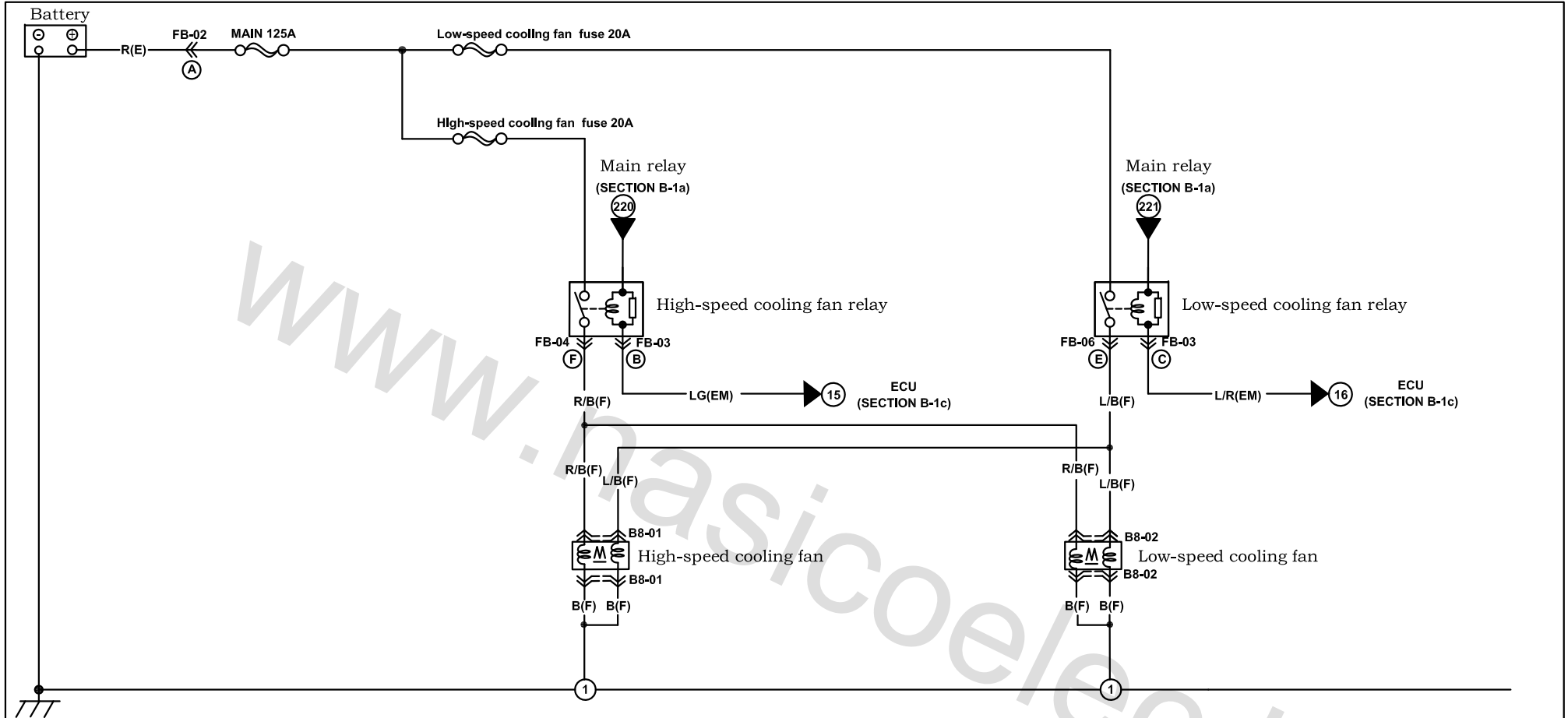

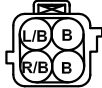
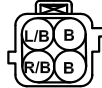

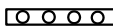
<p><b>B8-01</b> High-speed cooling fan (F)</p> 	<p><b>B8-02</b> Low-speed cooling fan (F)</p> 					

Harness mark:  (F)  (E)  (D)  (R)

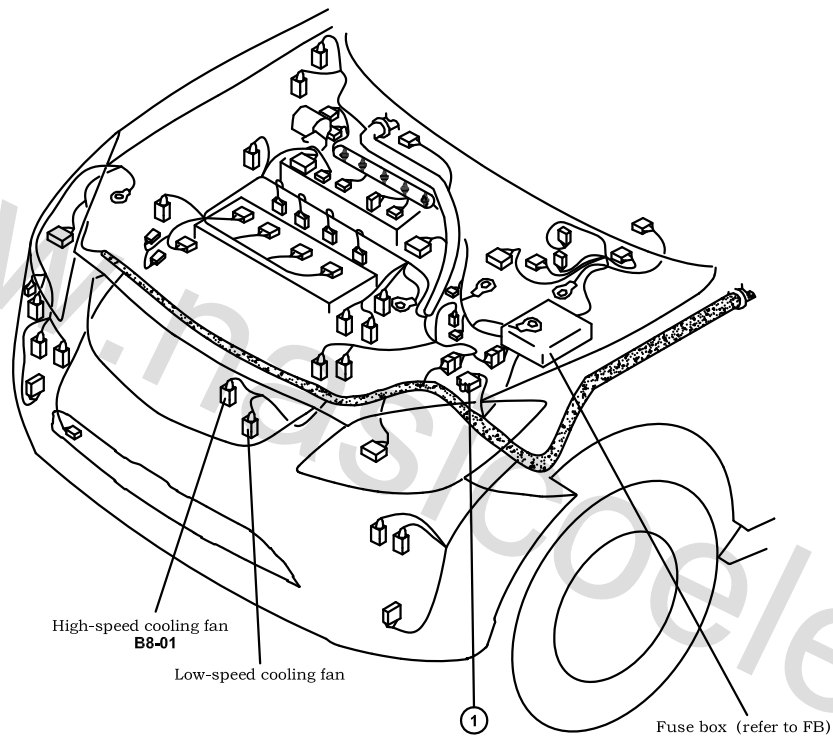

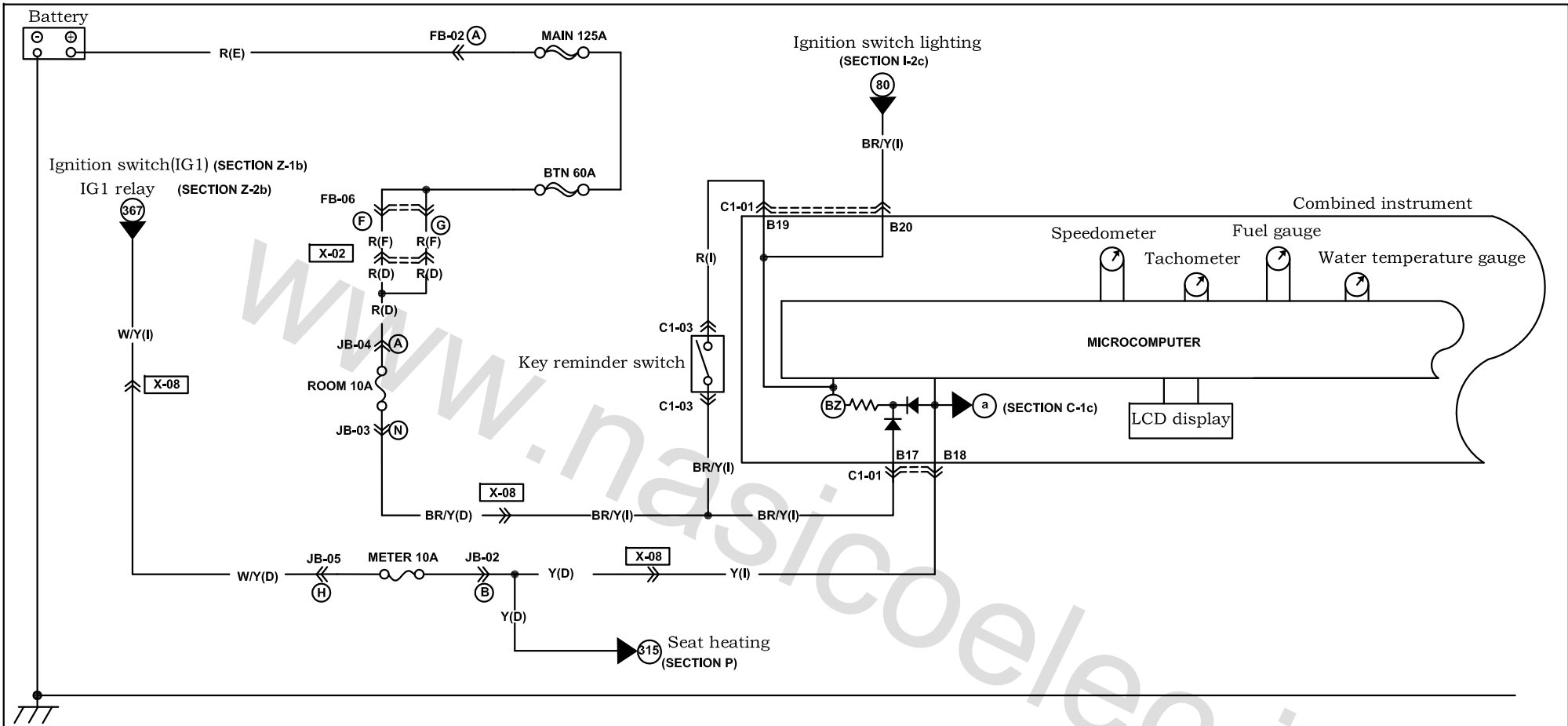

C1-01 Combined instrument (I)

( ) with ESP

A1	B/Y	B/L	B/W	B/R	R/Y	P	Y/G	(G/O)	(V/W)	*	*	*	*	*	*	*	A16
A17	LG	LG/B	*	*	*	*	*	*	*	*	*	G/B	LG/R	G/W	G/R	Y/L	A32

C1-01 Combined instrument (I)

\$ with PEPS  
@ with ignition switch

B1	B	B/G	L/O	*	BR/G	\$L/B	\$L/W	G/Y	B/W	GR	GR/Y	Y/R	BR/W	L/R	V	Y/B	B16
B17	BR/Y	Y	@R	@V/W	BR/E	*	*	*	*	*	*	*	*	*	*	*	B32

C1-03 Key reminder switch (I)

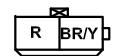

Harness mark:  (F)  (E)  (D)  (R)

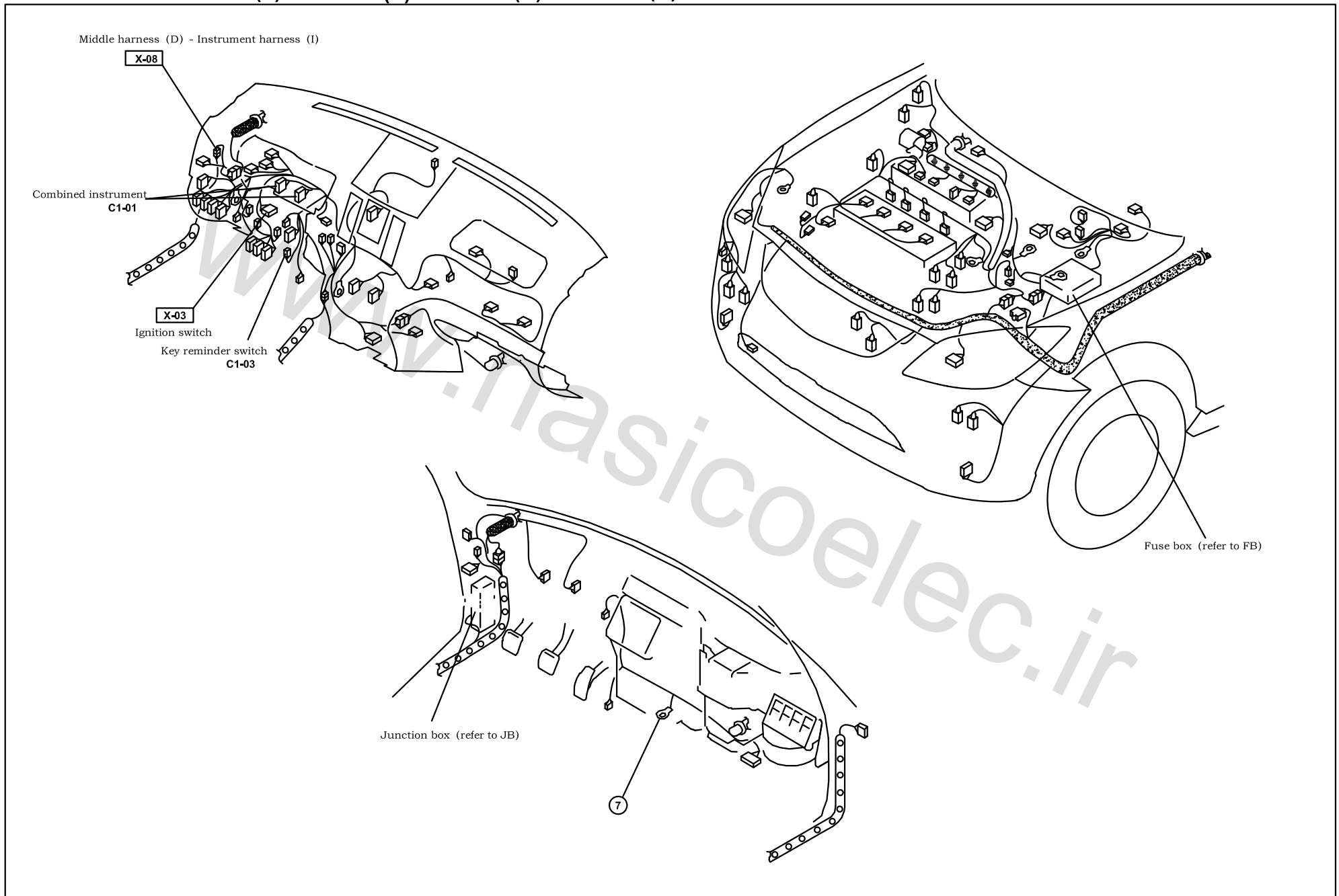

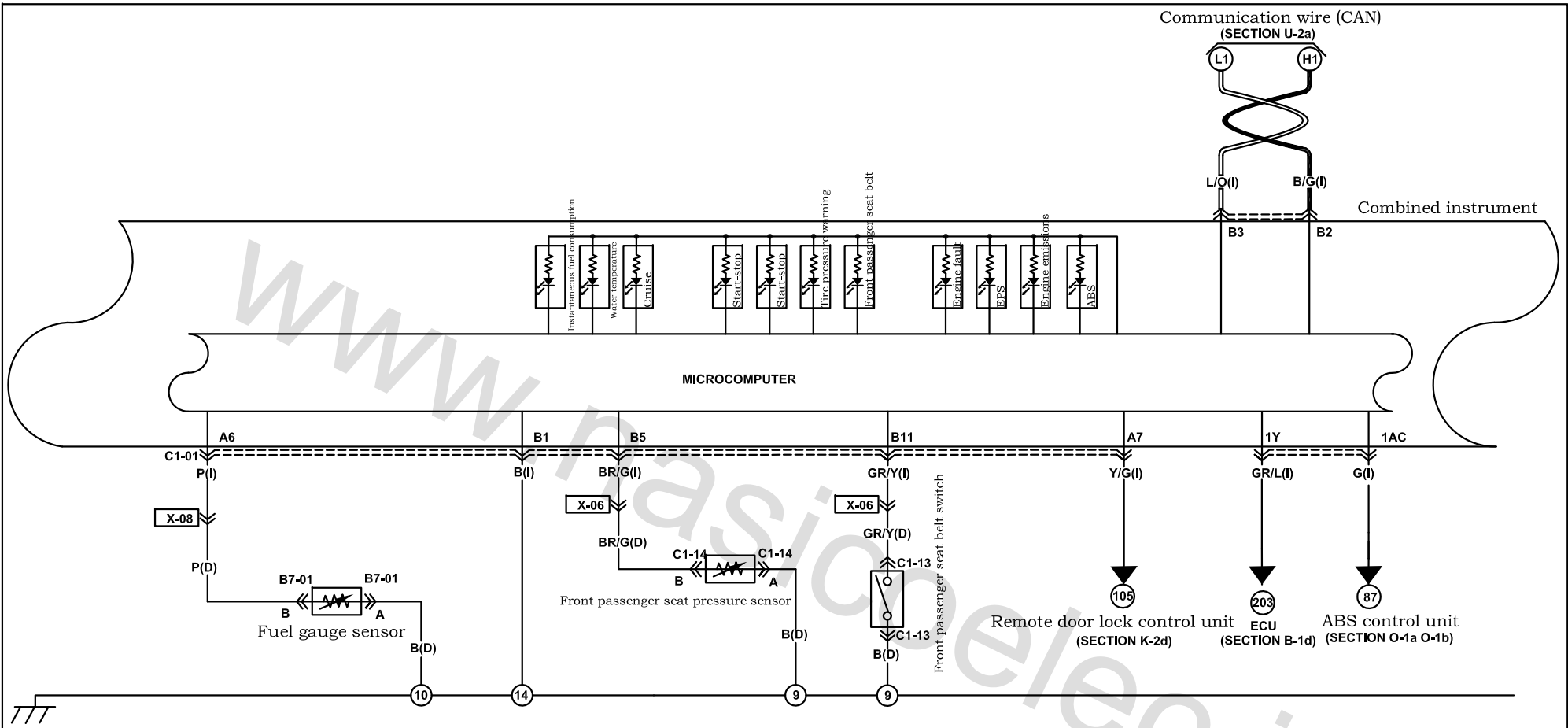

C1-01 Combined instrument (I)

( ) with ESP

A1	B/Y	B/L	B/W	B/R	R/Y	P	Y/G	(G/O)	(V/W)	*	*	*	*	*	*	A16
A17	LG	LG/B	*	*	*	*	*	*	*	*	*	G/B	LG/R	G/W	G/R	Y/L

C1-01 Combined instrument (I)

\$ with PEPS  
@ with ignition switch

B1	B	B/G	L/O	*	BR/G	\$/L/B	\$/L/W	G/Y	B/W	GR	GR/Y	Y/R	BR/W	L/R	V	Y/B	B16
B17	BR/Y	Y	@/R	@/V/W	BR/E	*	*	*	*	*	*	*	*	*	*	*	B32

B7-01 Fuel gauge sensor (D)

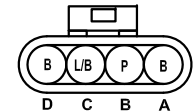



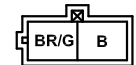

C1-13 Front passenger seat belt switch(D)

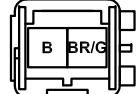

C1-14 Front passenger seat pressure sensor(D)

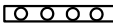

Harness mark:  (F)  (E)  (D)  (R)

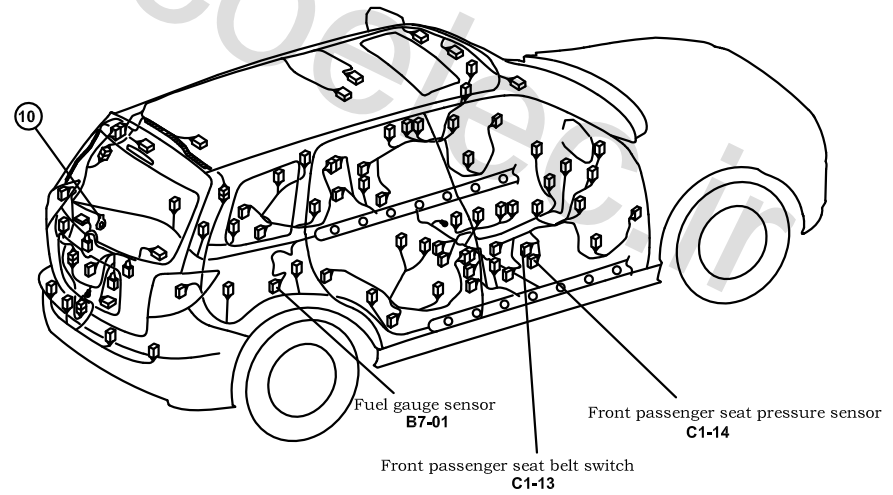
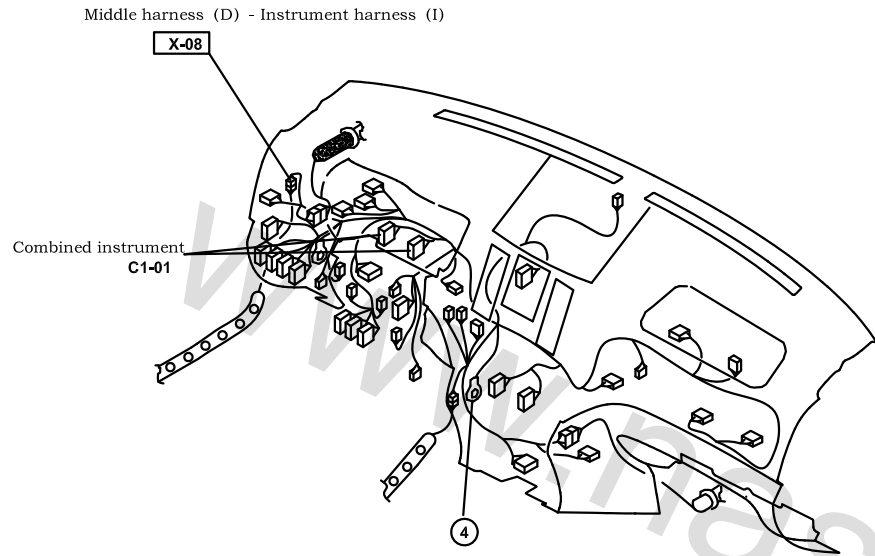

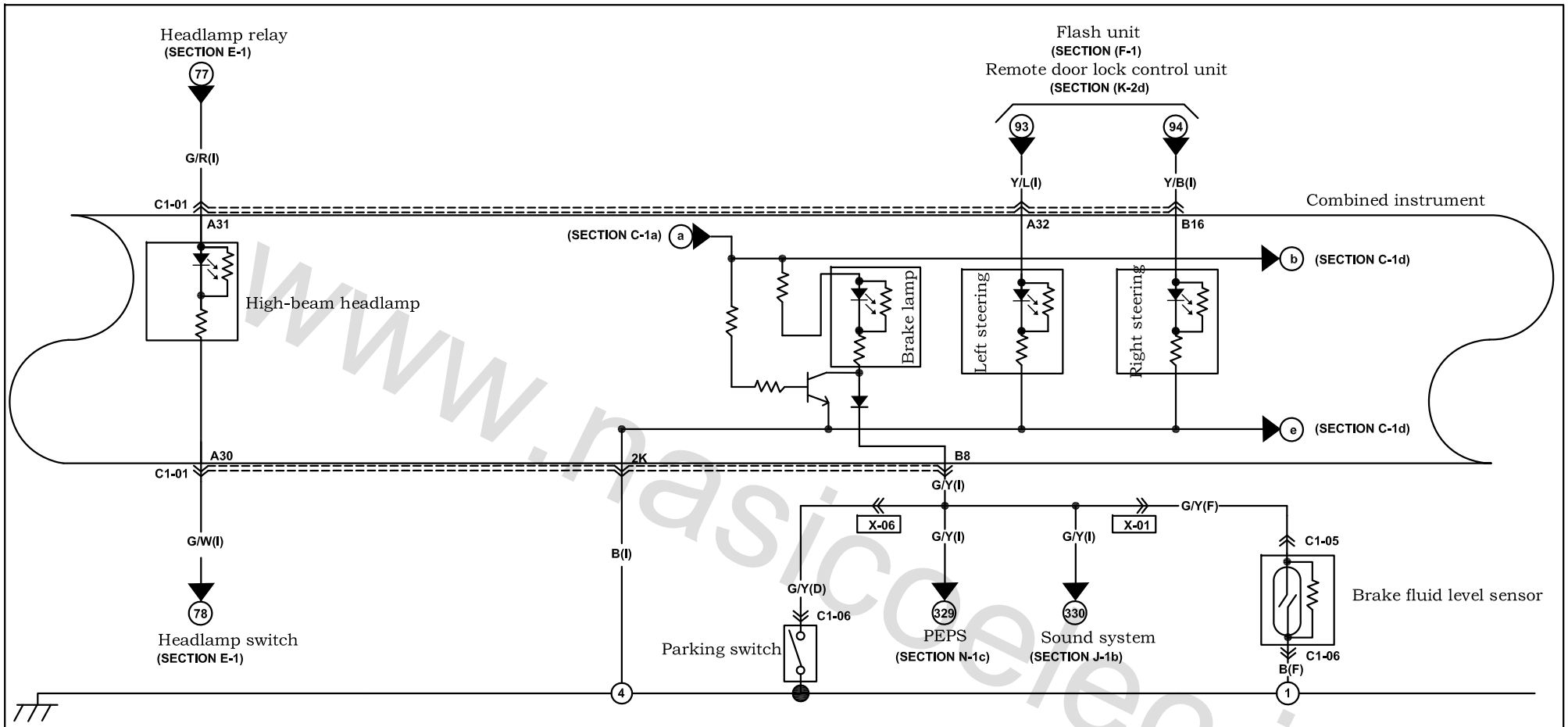

C1-01 Combined instrument (I) ( ) with ESP



A1	B/Y	B/L	B/W	B/R	R/Y	P	Y/G	(G/O)	(V/W)	*	*	*	*	*	*	*	A16
A17	LG	LG/B	*	*	*	*	*	*	*	*	*	G/B	LG/R	G/W	G/R	Y/L	A32

C1-01 Combined instrument (I) \$ with PEPS @ with ignition switch

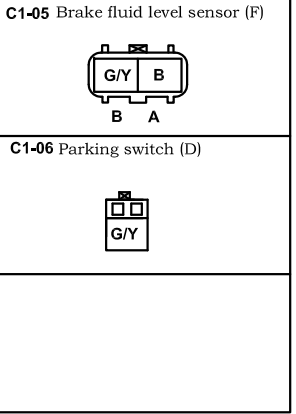
B1	B	B/G	L/O	*	BR/G	\$L/B	\$L/W	G/Y	B/W	GR	GR/Y	Y/R	BR/W	L/R	V	Y/B	B16
B17	BR/Y	Y	@R	@V/W	BR/E	*	*	*	*	*	*	*	*	*	*	*	B32



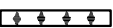
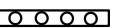

Harness mark:  (F)  (E)  (D)  (R)

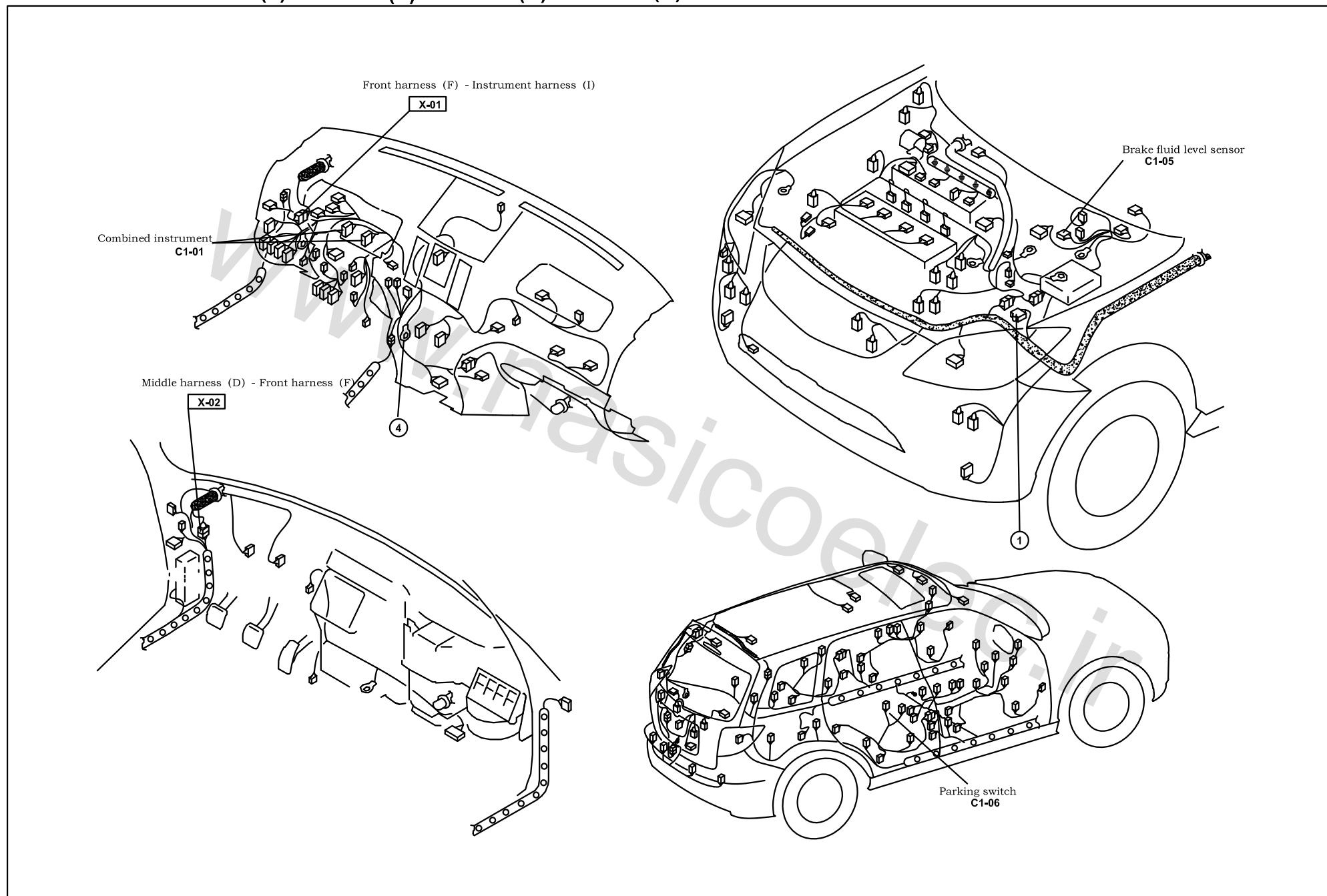

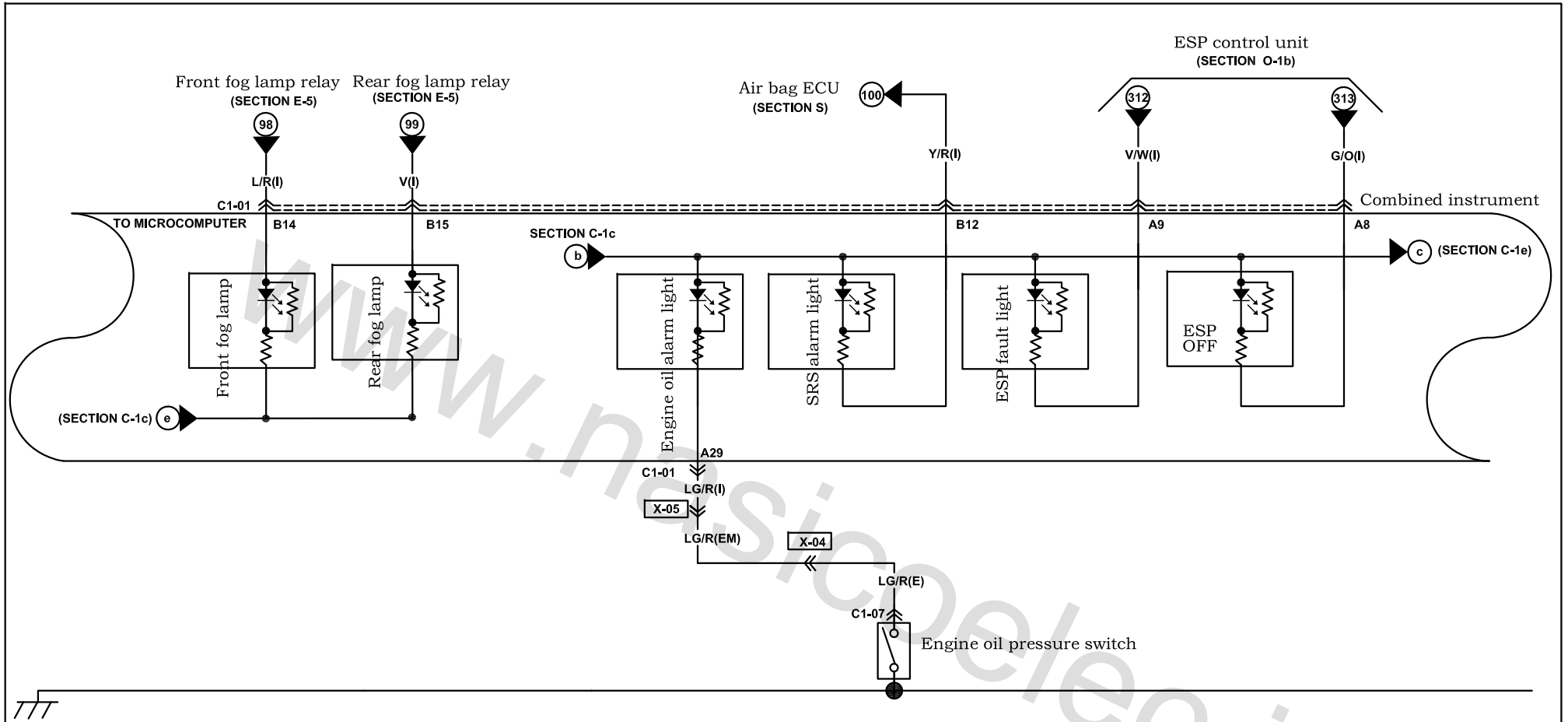

C1-01 Combined instrument (I)

( ) with ESP

A1	B/Y	B/L	B/W	B/R	R/Y	P	Y/G	(G/O)	(V/W)	*	*	*	*	*	*	A16
A17	LG	LG/B	*	*	*	*	*	*	*	*	*	G/B	LG/R	G/W	G/R	Y/L

C1-01 Combined instrument (I)

\$ with PEPS  
@ with ignition switch

B1	B	B/G	L/O	*	BR/G	\$L/B	\$L/W	G/Y	B/W	GR	GR/Y	Y/R	BR/W	L/R	V	Y/B	B16
B17	BR/Y	Y	@R	@V/W	BR/E	*	*	*	*	*	*	*	*	*	*	*	B32

C1-07 Engine oil pressure switch(E)



Harness mark:  (F)  (E)  (D)  (R)

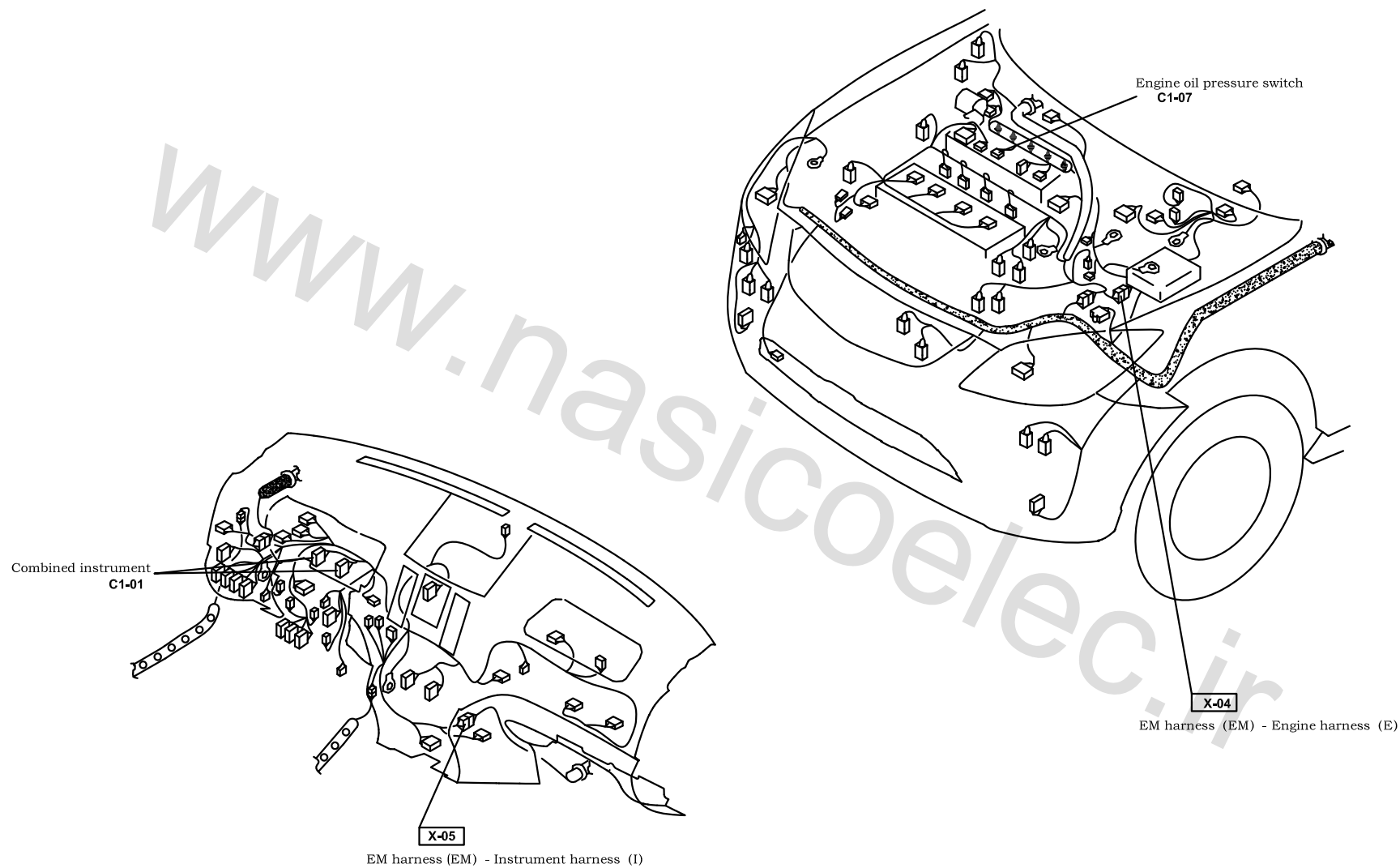

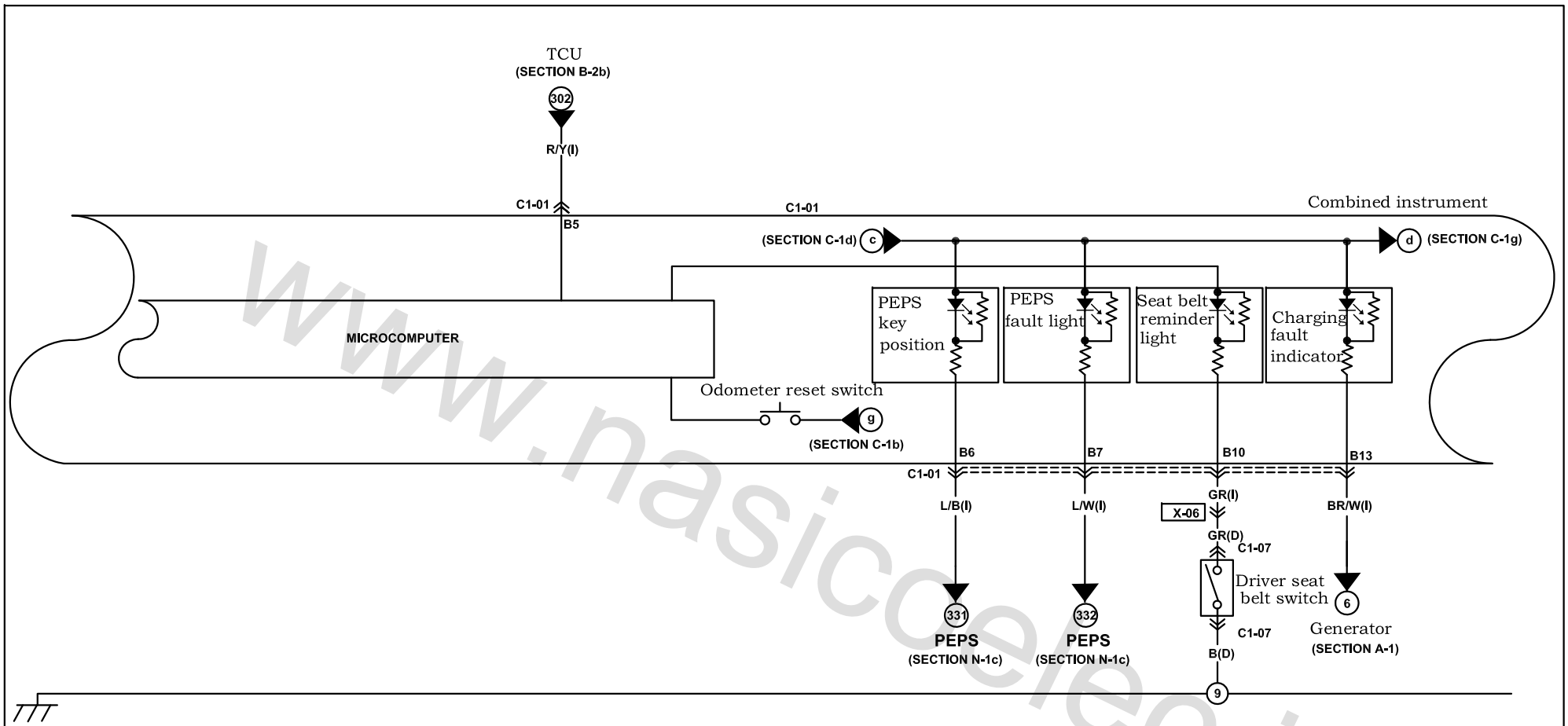

C1-01 Combined instrument (I)

( ) with ESP

A1	B/Y	B/L	B/W	B/R	R/Y	P	Y/G	(G/O)	(V/W)	*	*	*	*	*	*	*	A16
A17	LG	LG/B	*	*	*	*	*	*	*	*	G/B	LG/R	G/W	G/R	Y/L	A32	

C1-01 Combined instrument (I)

\$ with PEPS  
@ with ignition switch

B1	B	B/G	L/O	*	BR/G	\$L/B	\$L/W	G/Y	B/W	GR	GR/Y	Y/R	BR/W	L/R	V	Y/B	B16
B17	BR/Y	Y	@	@	@	BR/E	*	*	*	*	*	*	*	*	*	*	B32

C1-07 Driver seat belt switch (D)

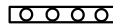
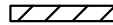

Harness mark:  (F)  (E)  (D)  (R)

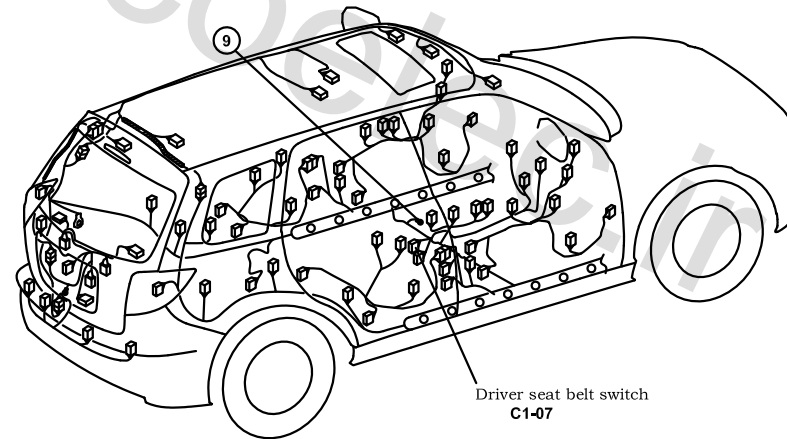
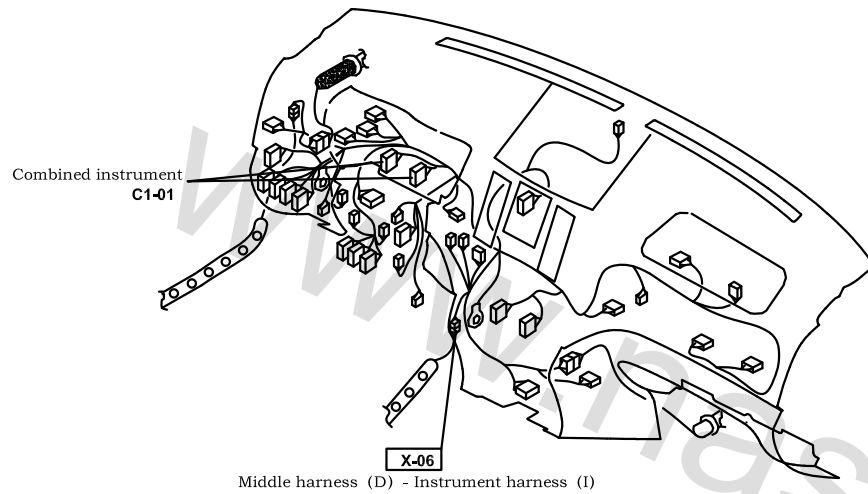

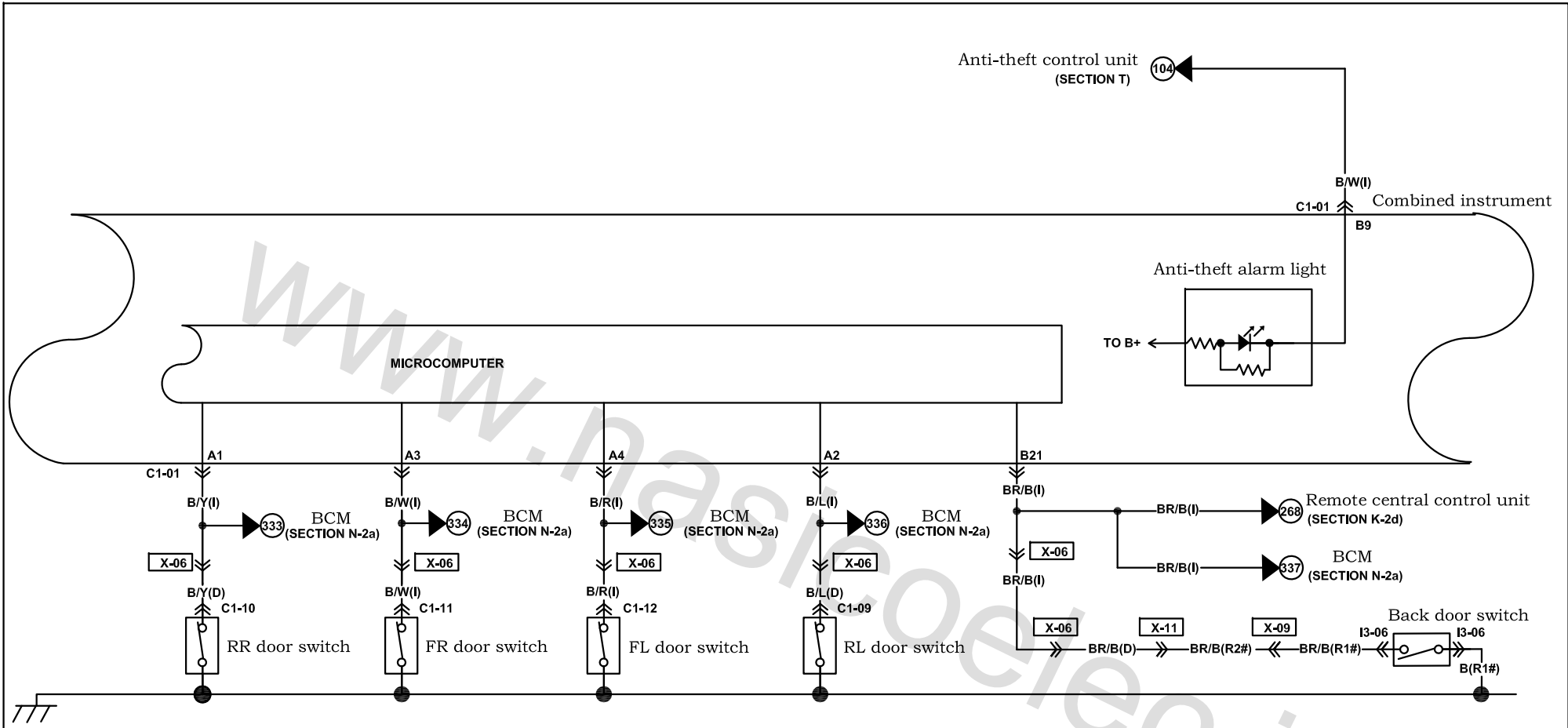

C1-01 Combined instrument (I) ( ) with ESP

C1-01 Combined instrument (I) \$ with PEPS @ with ignition switch

C1-10 RR door switch(D) C1-11 FR door switch(D)

C1-12 FL door switch(D) C1-09 RL door switch(D)

I3-06 Back door switch (R1#)

A1	B/Y	B/L	B/W	B/R	R/Y	P	Y/G	(G/O)	(V/W)	*	*	*	*	*	*	A16
A17	LG	LG/B	*	*	*	*	*	*	*	*	*	G/B	LG/R	G/W	G/R	Y/L

B1	B	B/G	L/O	*	BR/G	\$L/B	\$L/W	G/Y	B/W	GR	GR/Y	Y/R	BR/W	L/R	V	Y/B	B16
B17	BR/Y	Y	@R	@V/W	BR/E	*	*	*	*	*	*	*	*	*	*	*	B32

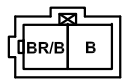

Harness mark:  (F)  (E)  (D)  (R)

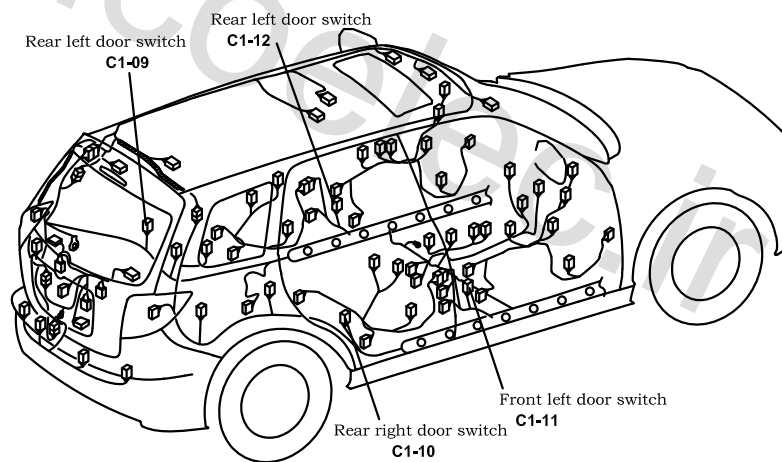
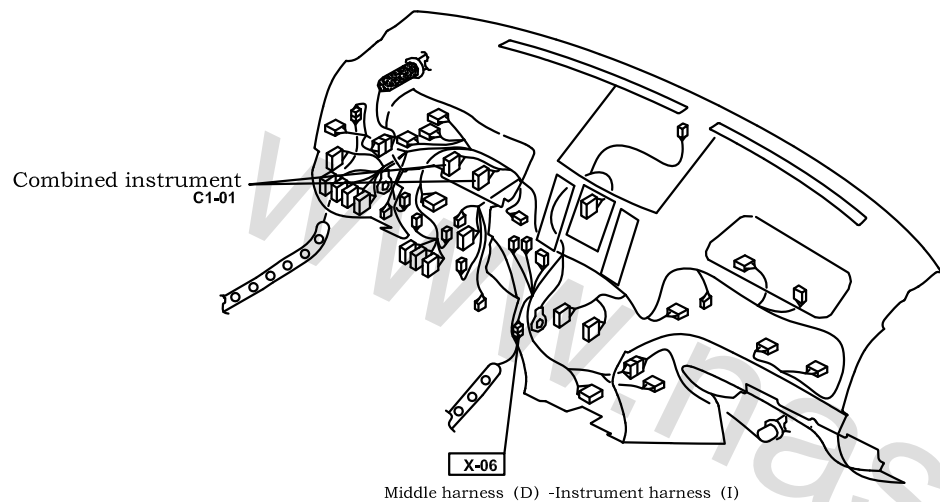

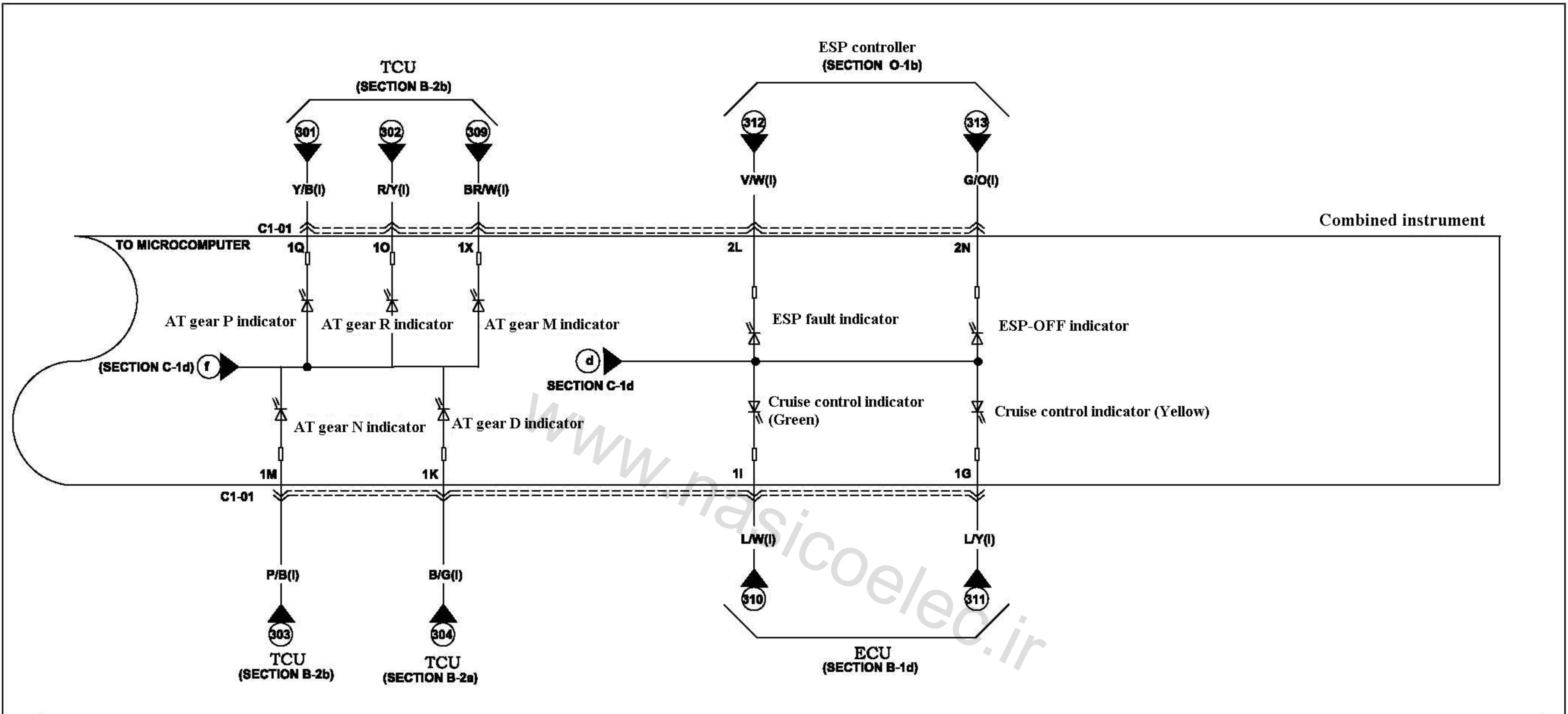

**C1-01 Combined instrument (I)**

( ) With ESP  
 [ ] With cruise control  
 <> AT

1AE	BR/Y	G	Y	GR/L	B	R/G	P	<Y/B>	* <R/Y>	* <P/B>	* <B/G>	* <L/W>	* <L/Y>	*	*	W	1A
1AF	LG/B	*	LG	*	<BR/W>	V/W	*	*	*	R	*	B/W	GR	P/L	Y/G	Y/R	1B

**C1-01 Combined instrument (I)**

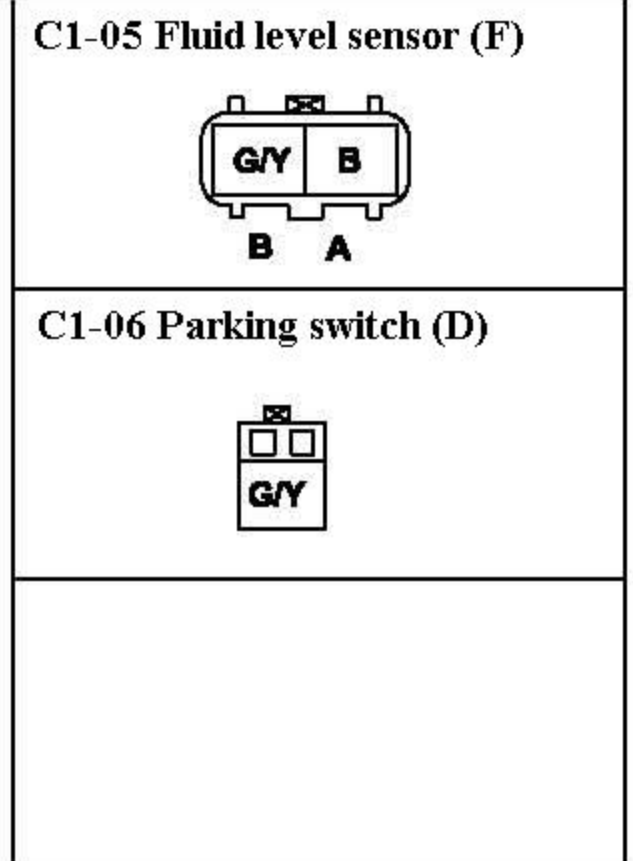

( ) With ESP  
 [ ] With cruise control  
 <> AT

2Q	Y/L	B/W	BR/B	B	GR/R	*	LG/R	BR/W	G/Y	2A
2R	Y/B	*	(G/O)	(V/W)	L/R	G/R	V	GW	*	2B



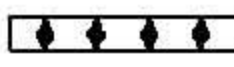
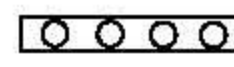

Harness

identification:  (F)  (E)  (D)  (R)

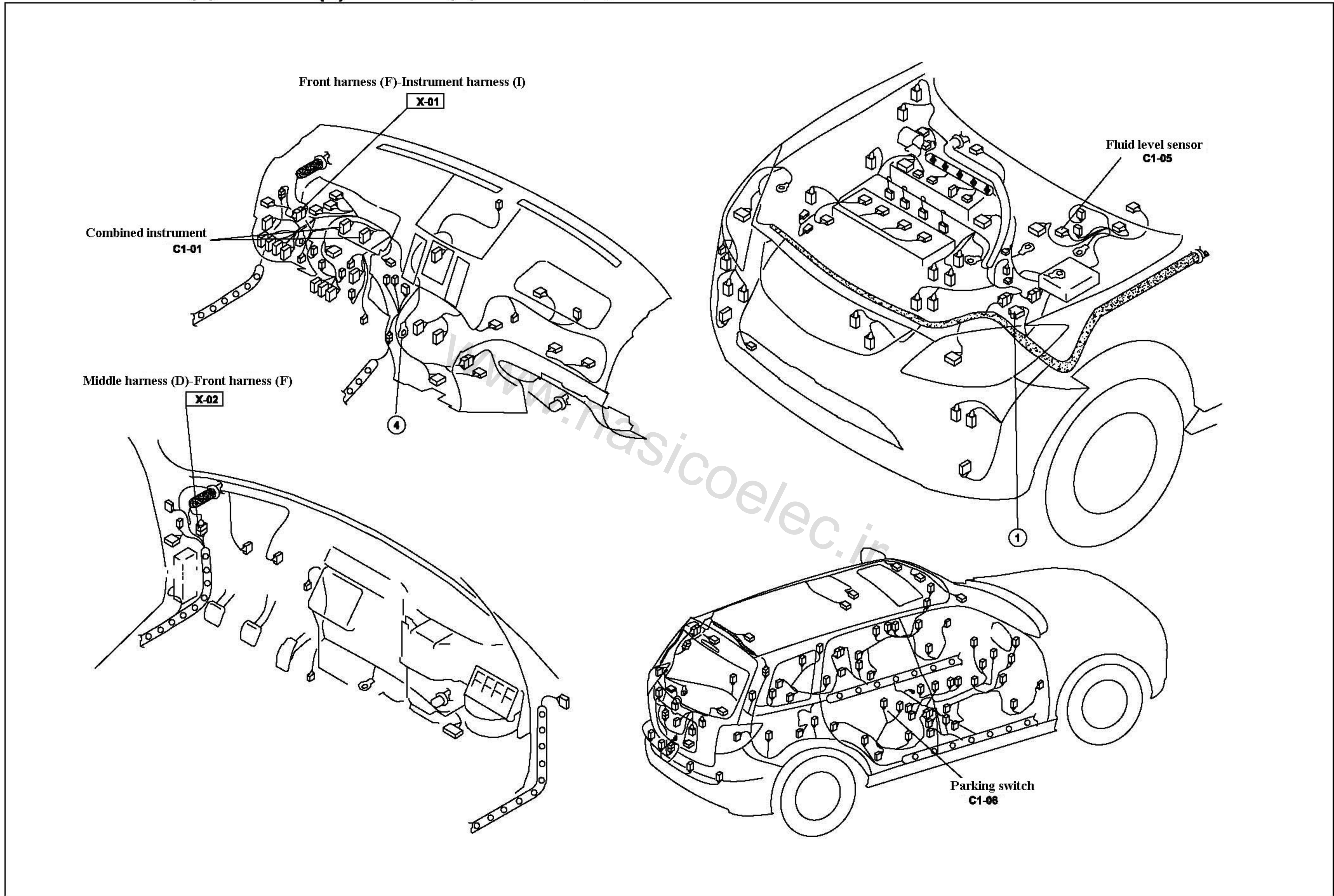

# Windshield wiper and washer

D-1a

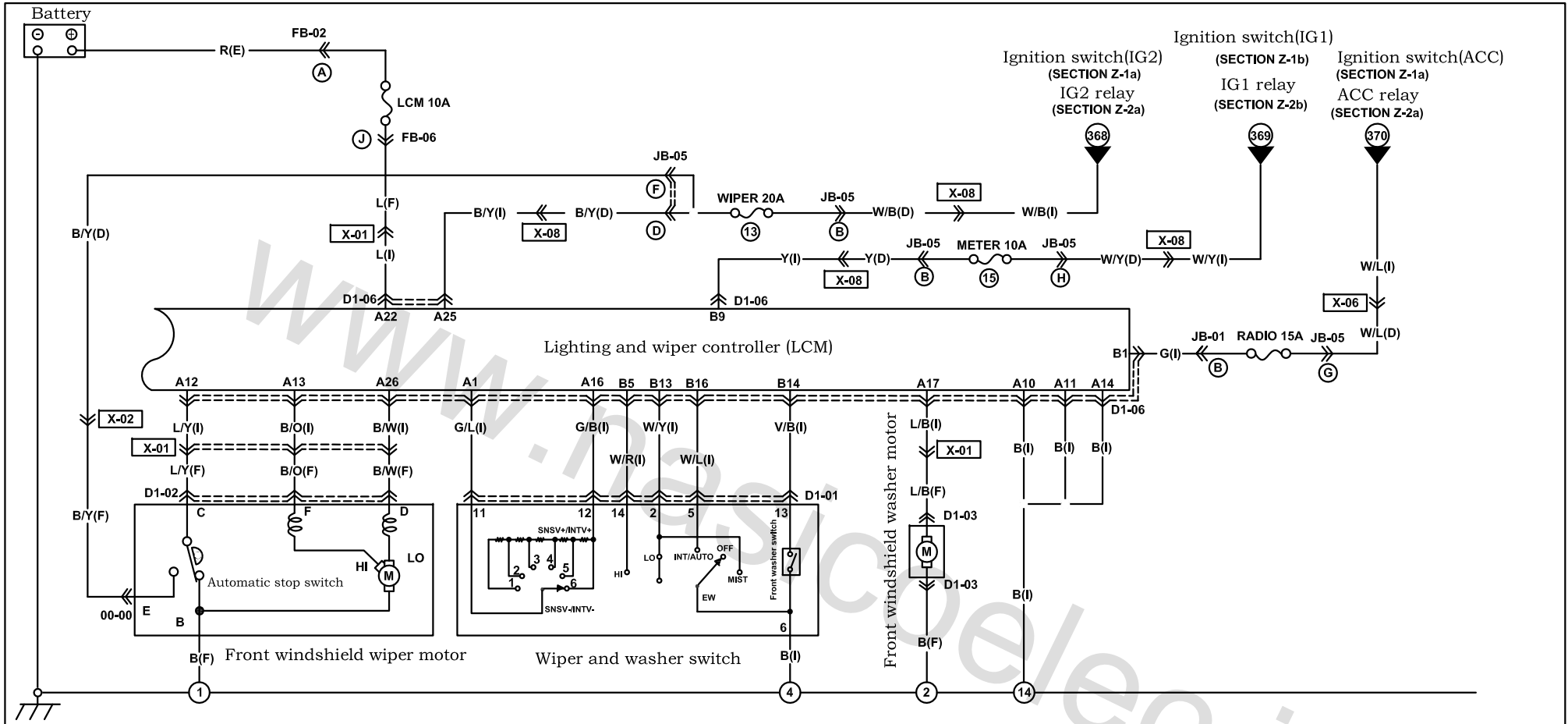

D1-01 Windshield wiper and washer switch (I)

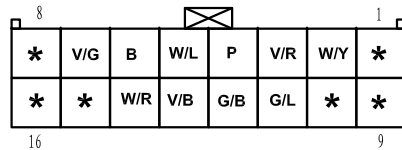

D1-02 Front windshield wiper motor (F)

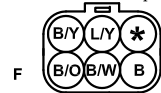

D1-03 Front windshield washer motor (F)

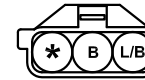



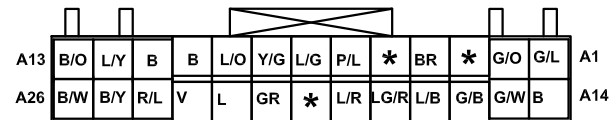

D1-06 Lighting and wiper controller (I)

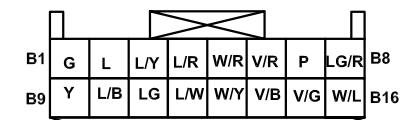

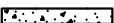
D1-06 Lighting and wiper controller (I)



Harness mark:  (F)  (E)  (D)  (R)

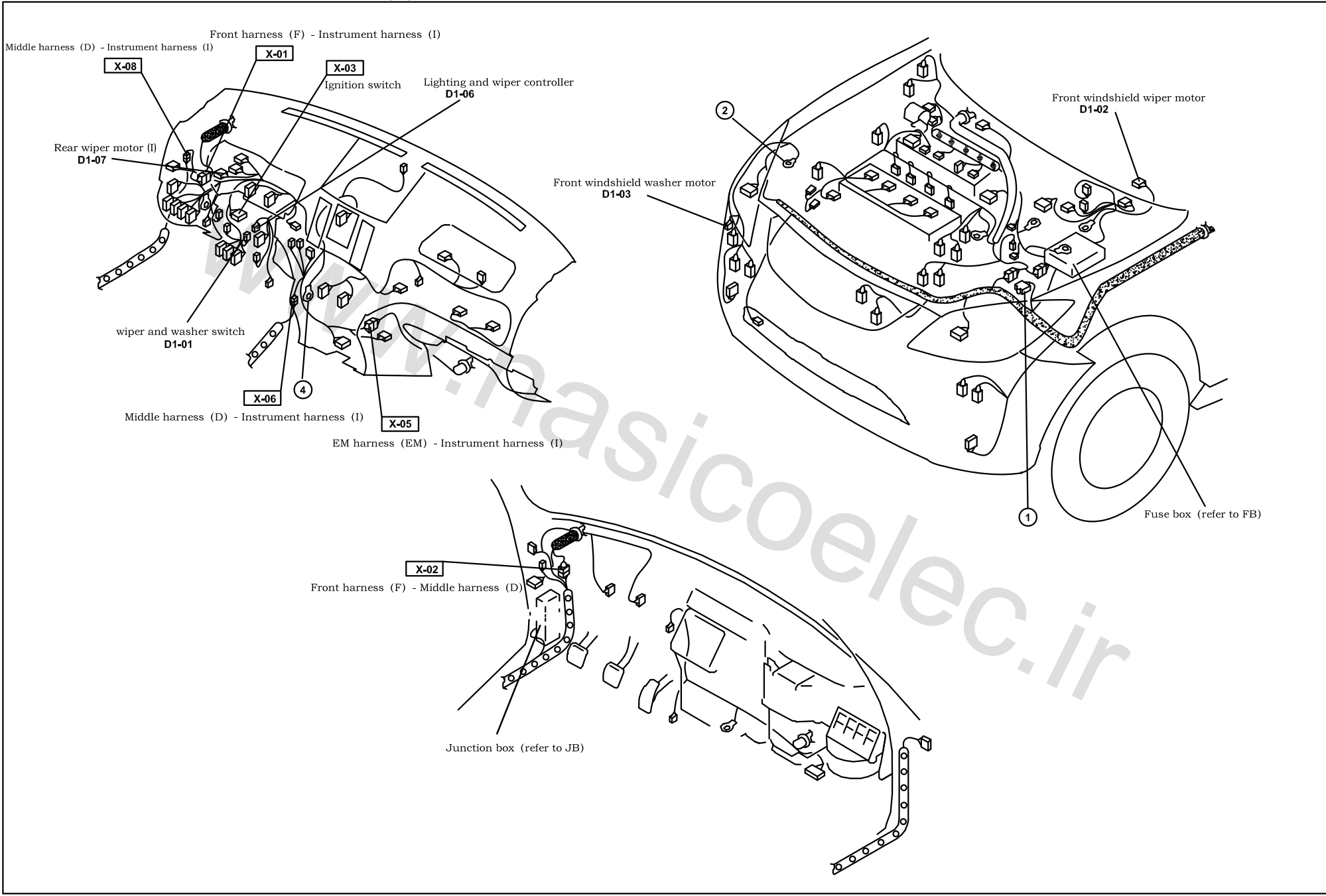

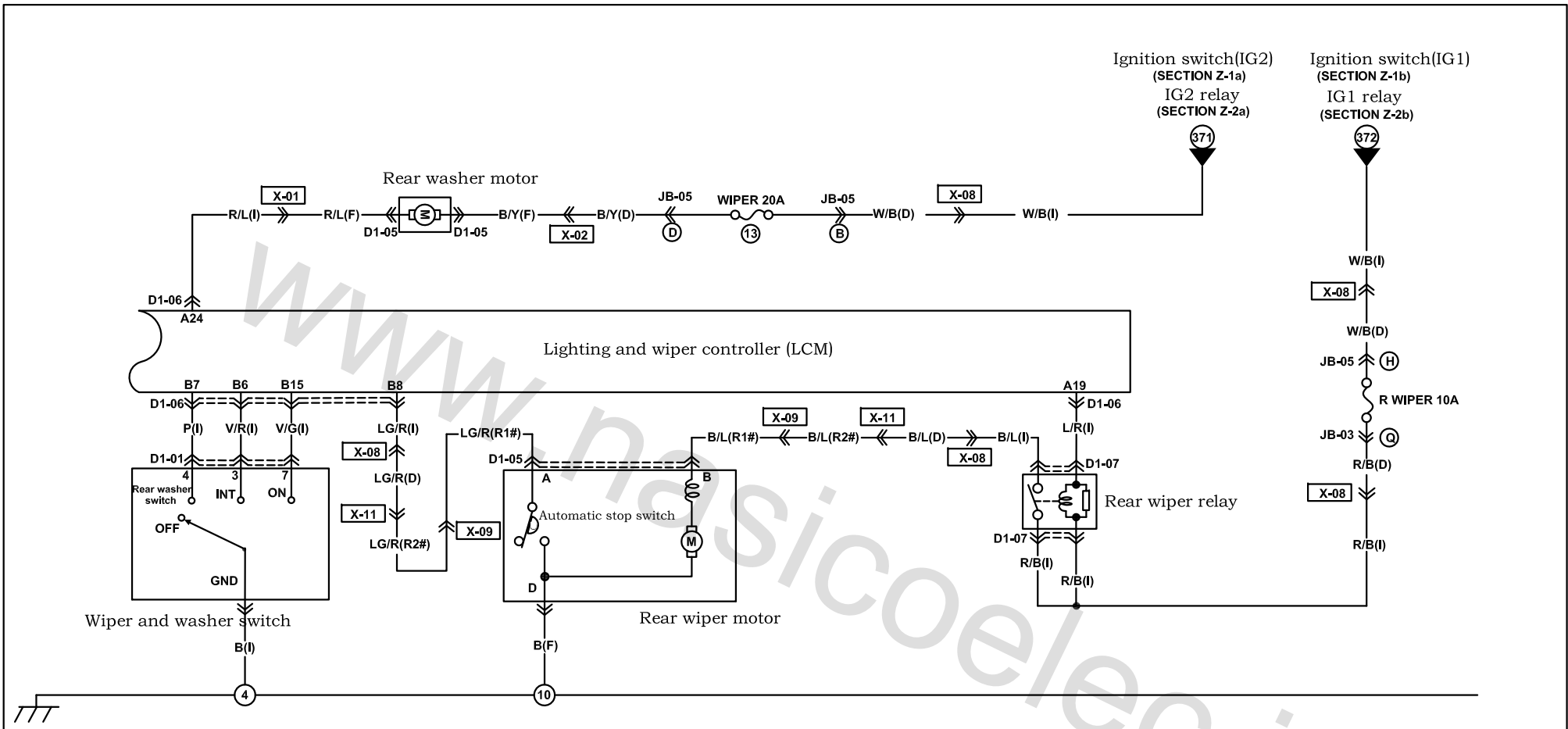

D1-01 Wiper and washer switch (I)

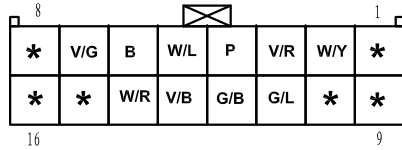

D1-04 Rear-window wiper motor



D1-05 Rear-window washer motor (F)



D1-07 Rear wiper relay (I)

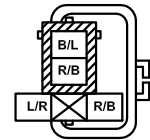

D1-06 Lighting and wiper controller (I)

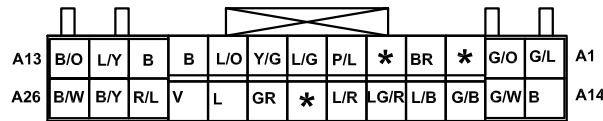

D1-06 Lighting and wiper controller (I)

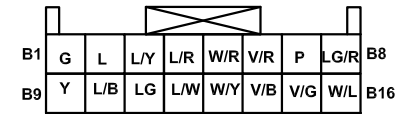

Harness mark:  (F)  (E)  (D)  (R)

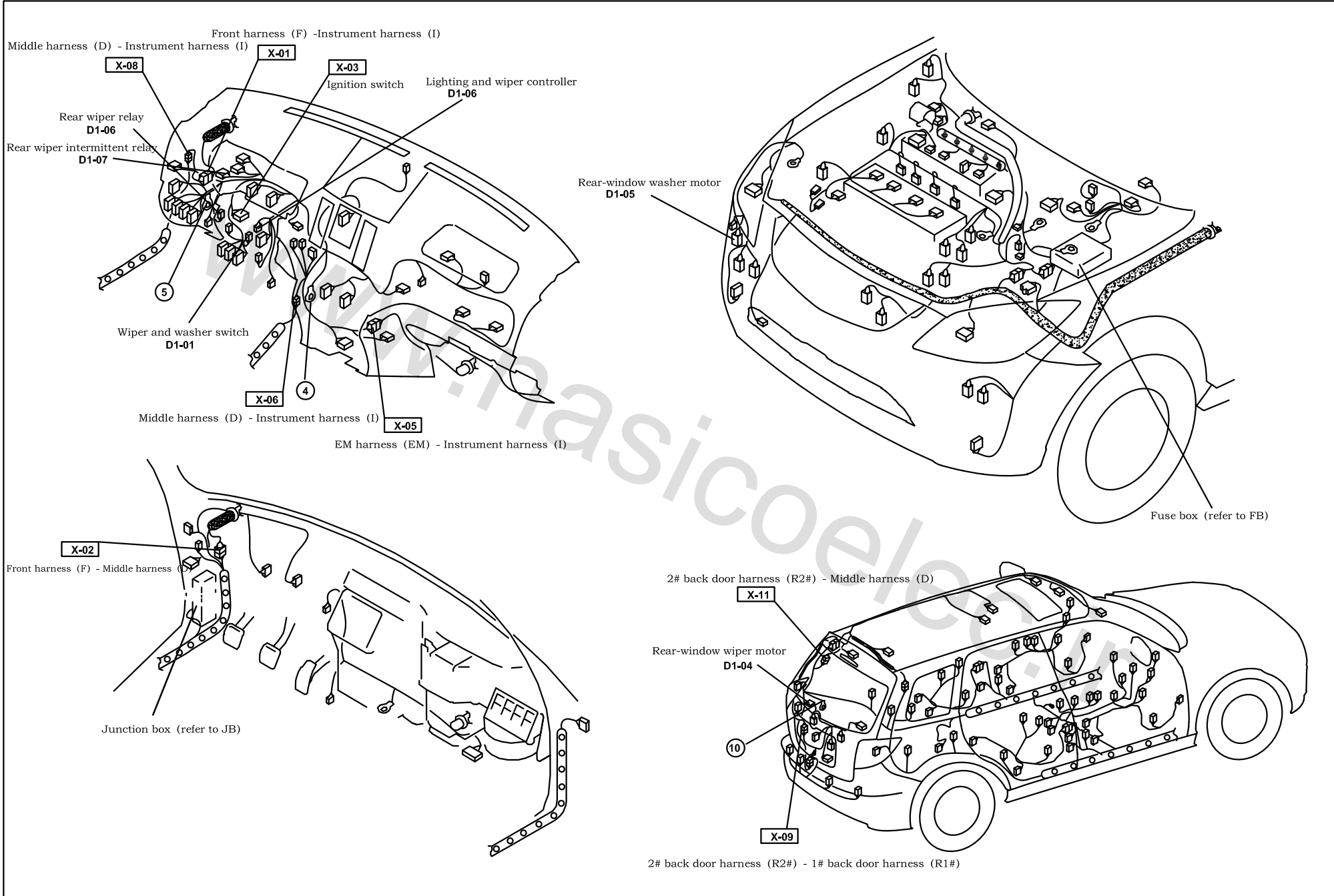

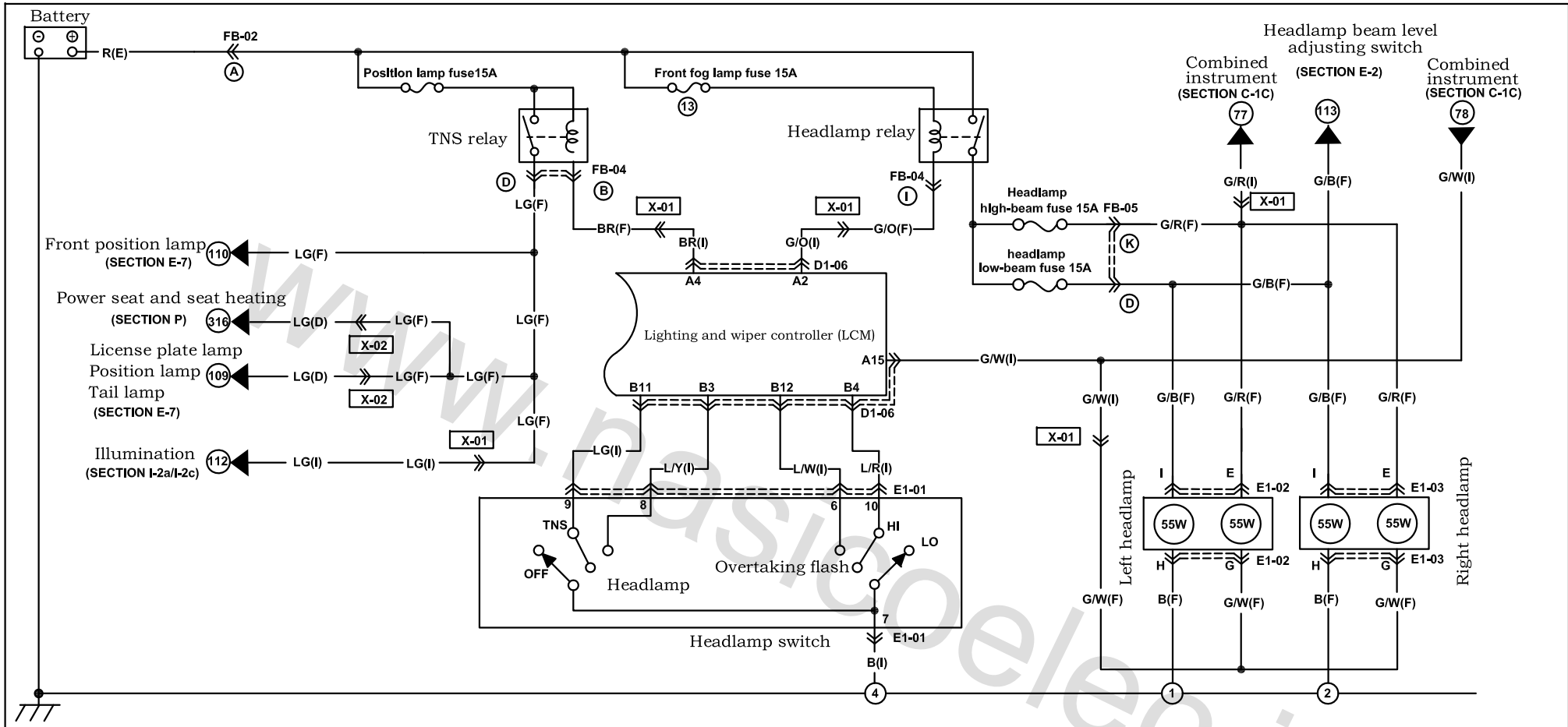

E1-01 Headlamp switch (I)

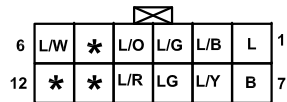

E1-02 Left headlamp (F)

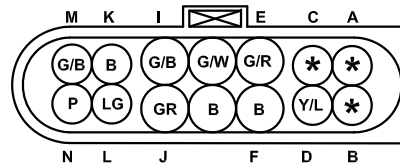

E1-03 Right headlamp (F)

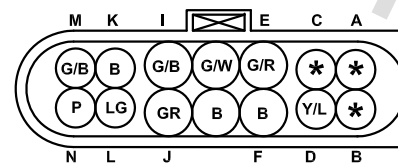

Harness mark:  (F)  (E)  (D)  (R)

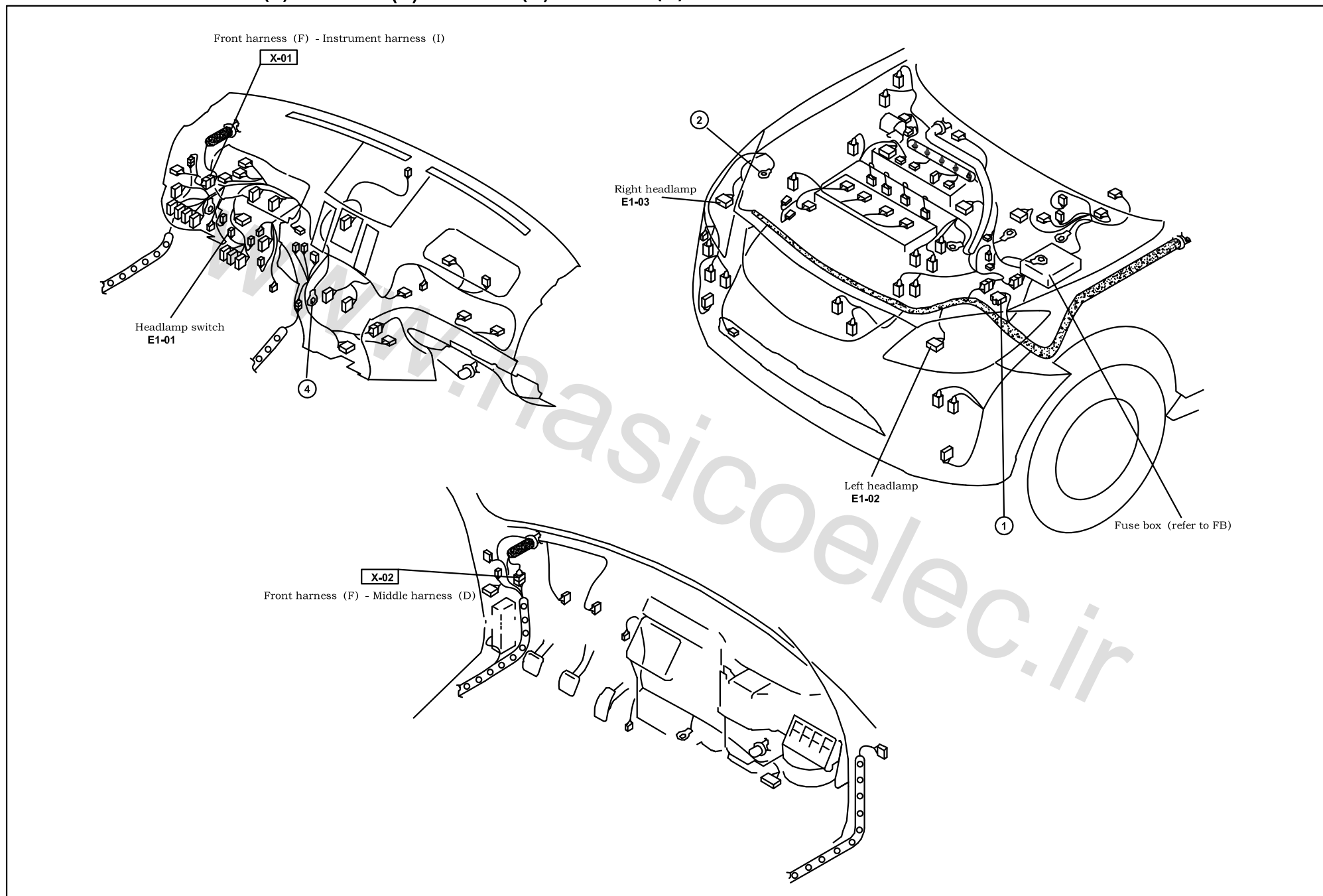

Headlamp beam level adjusting switch

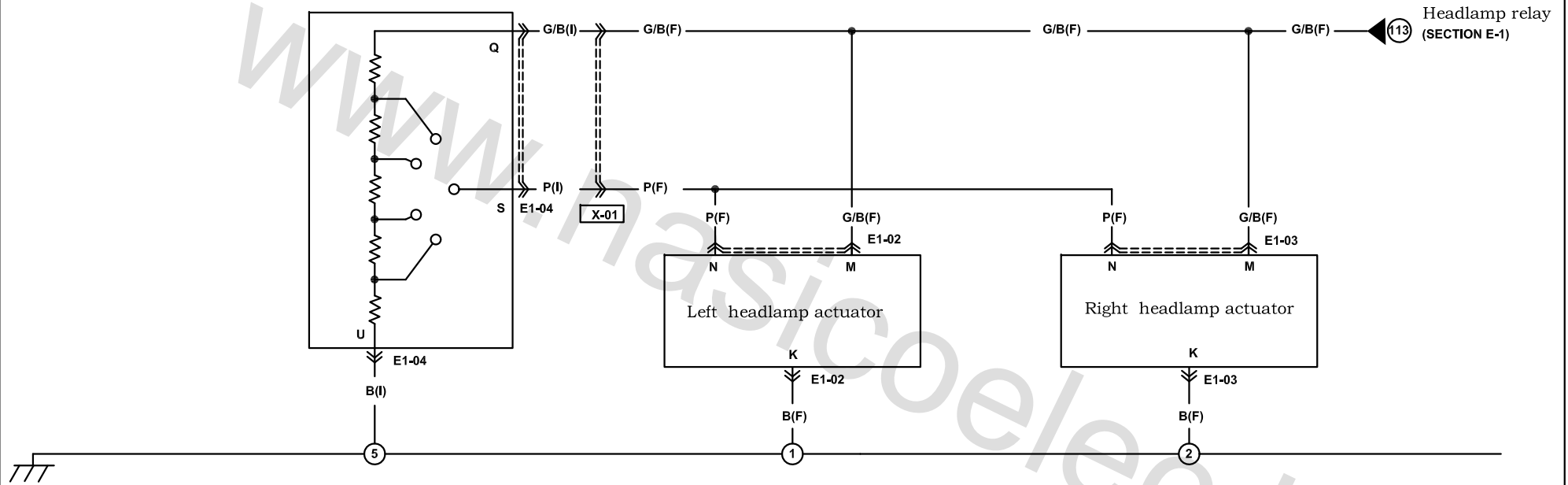

E1-01 Headlamp switch (D)

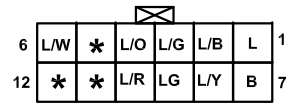

E1-02 Left headlamp (F)

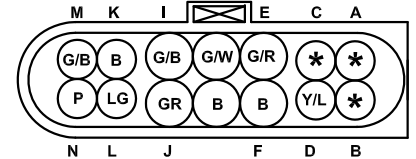

E1-03 Right headlamp (F)

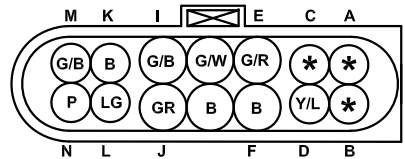

L1-01 Headlamp beam level adjusting switch (I)

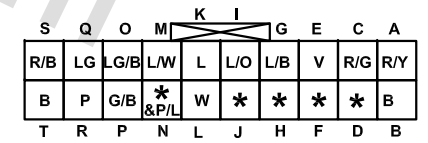



Harness mark:  (F)  (E)  (D)  (R)

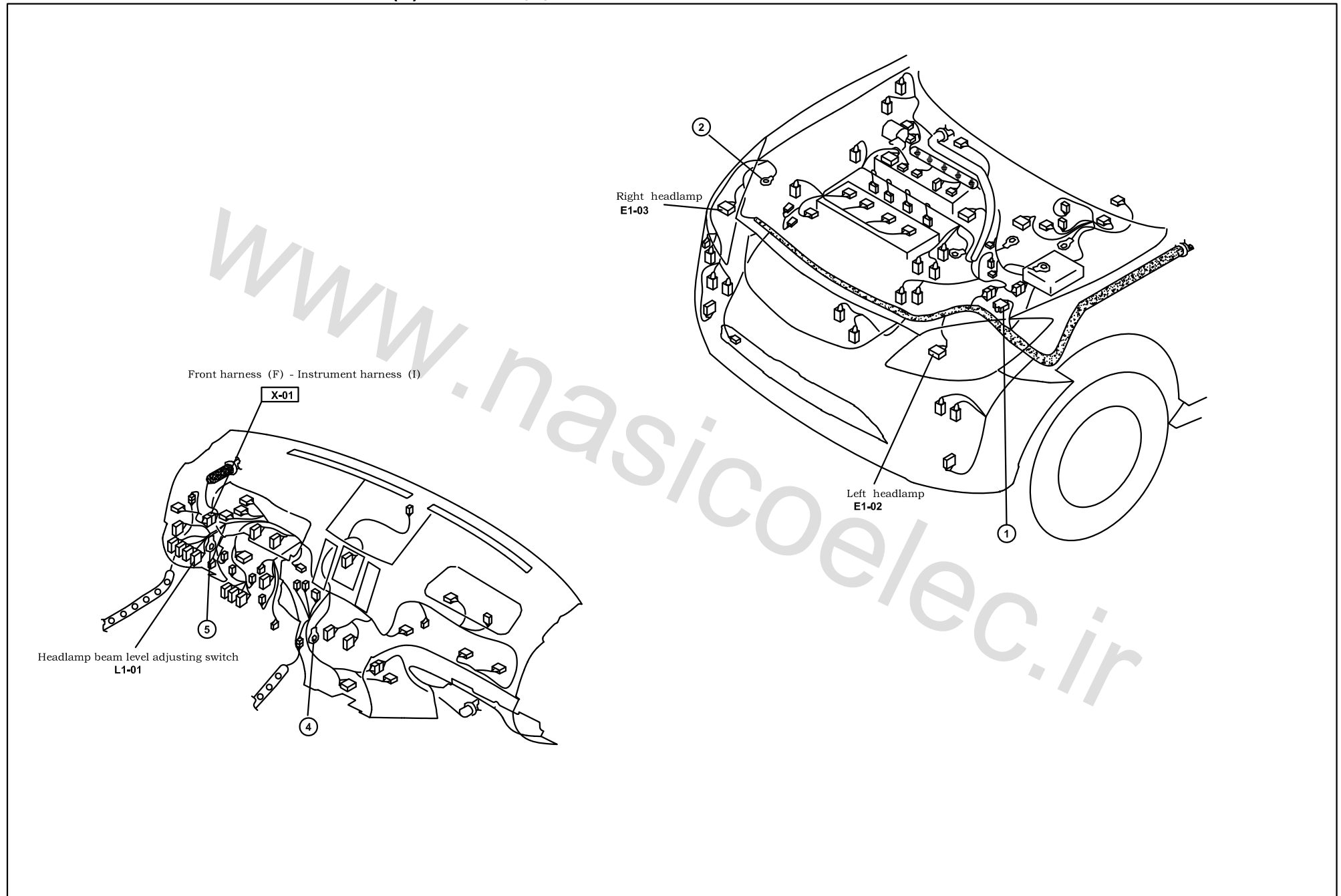

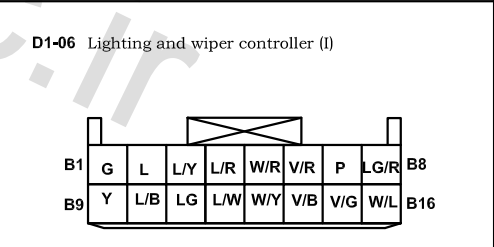
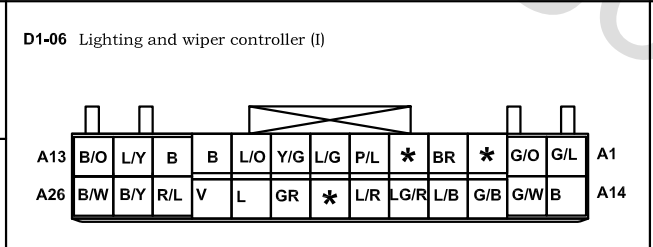
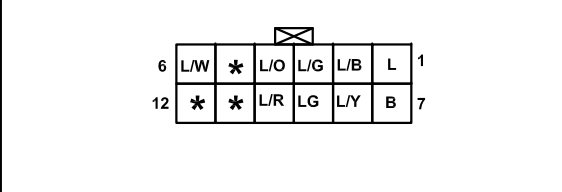
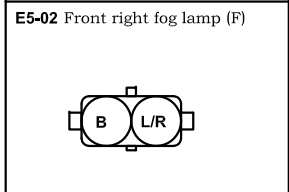
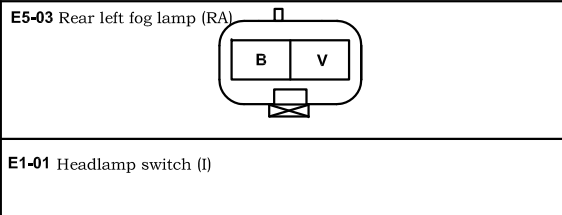
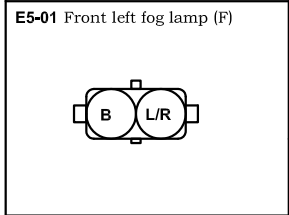
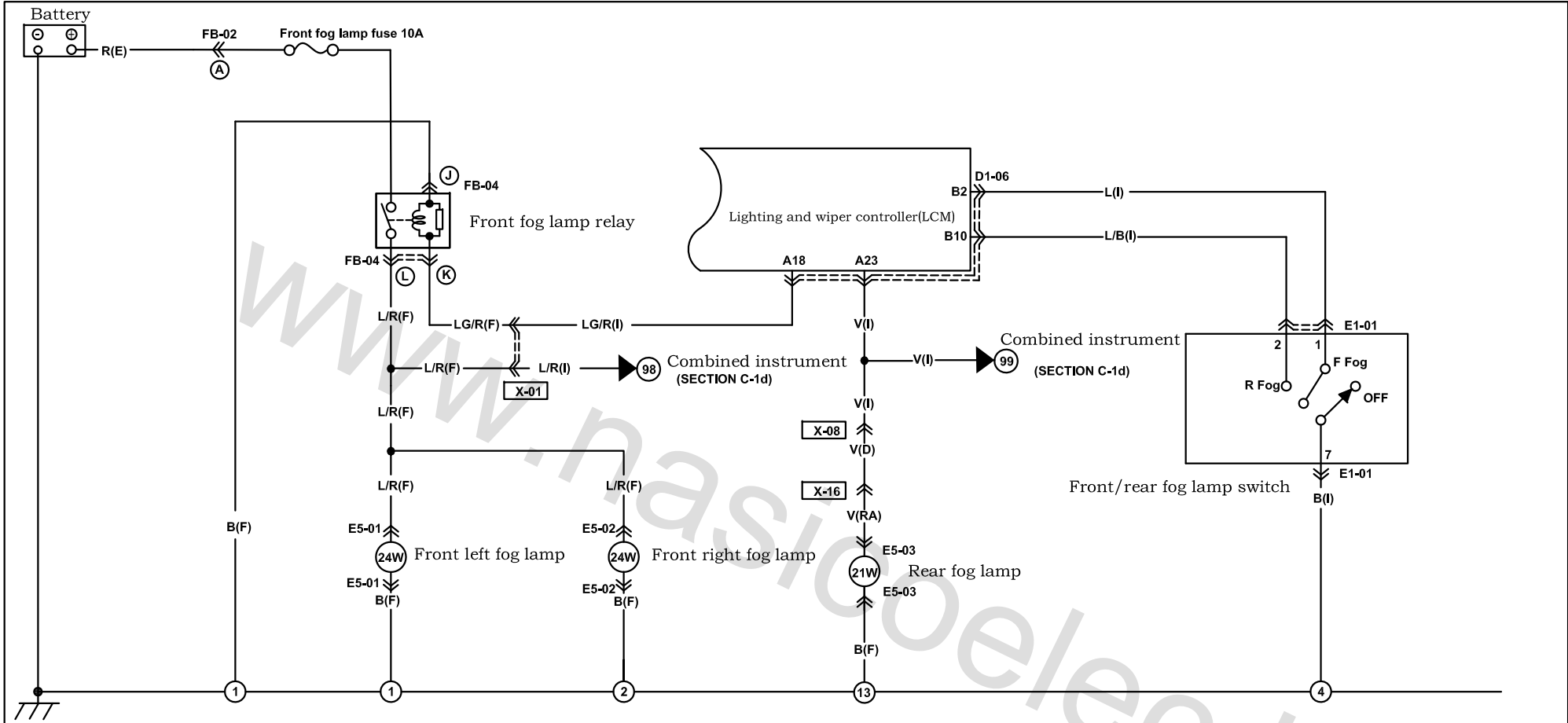

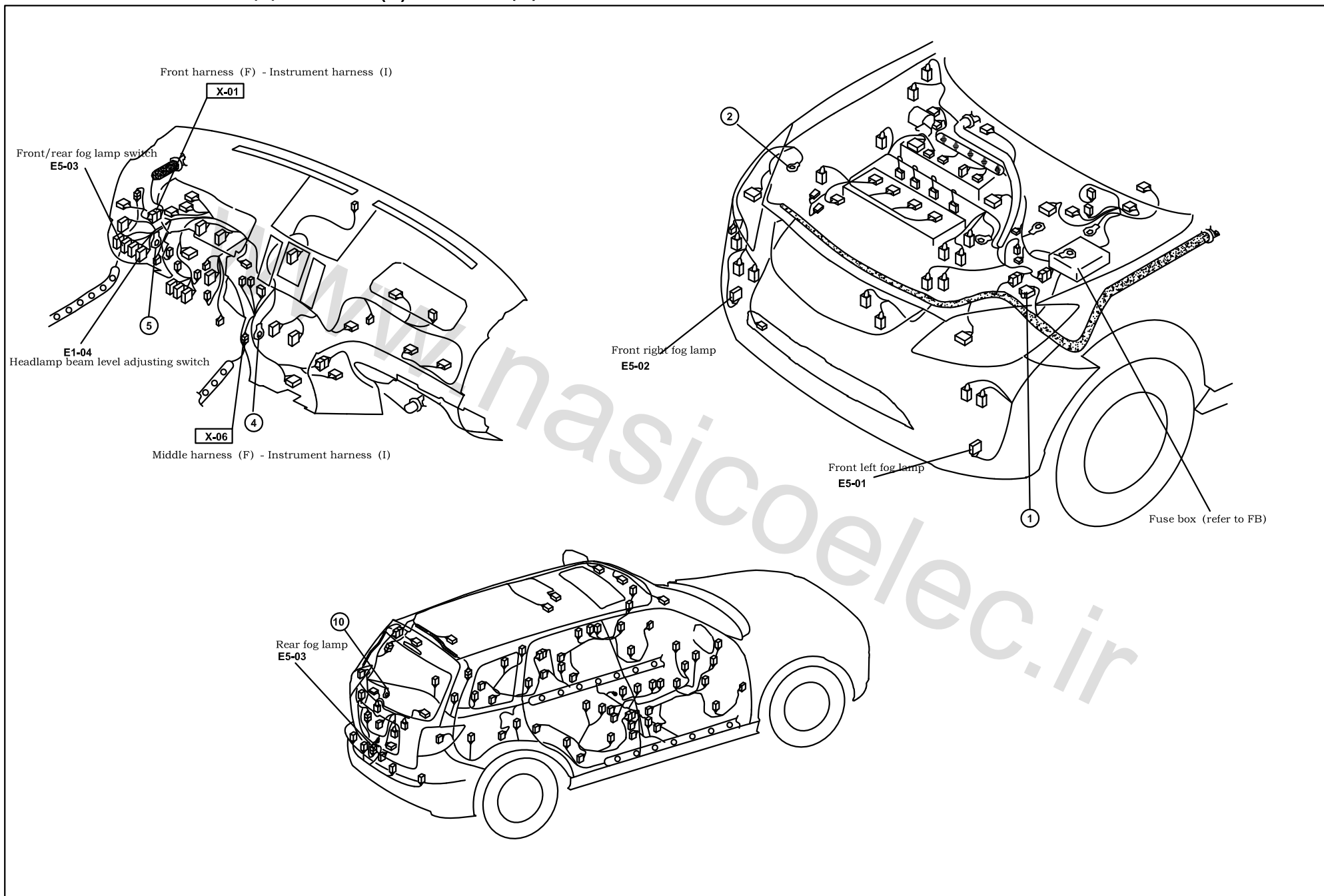

Harness mark:  (F)  (E)  (D)  (R)

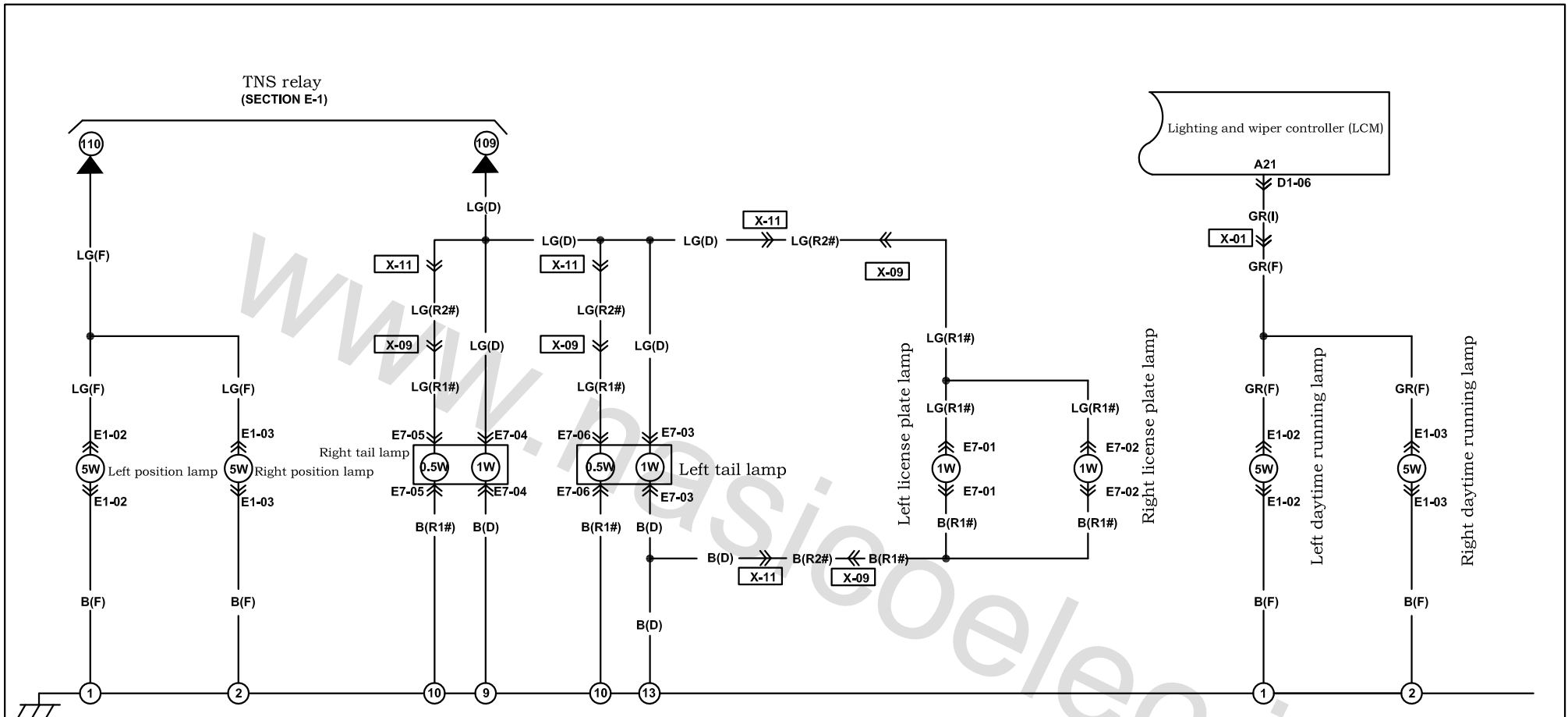

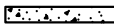
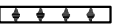
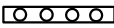

<p><b>E7-01</b> Left license plate lamp (R1#)</p>	<p><b>E7-02</b> Right license plate lamp (R1#)</p>	<p><b>E7-03</b> Left tail lamp (D)</p>	<p><b>E7-04</b> Right tail lamp (D)</p>	<p><b>E1-02</b> Left position lamp (F)</p>	
<p><b>E1-03</b> Right position lamp (F)</p>		<p><b>E7-05</b> Left trim lamp(tail lamp)(R2#)</p>	<p><b>E7-06</b> Right trim lamp(tail lamp)(R2#)</p>		

Harness mark:  (F)  (E)  (D)  (R)

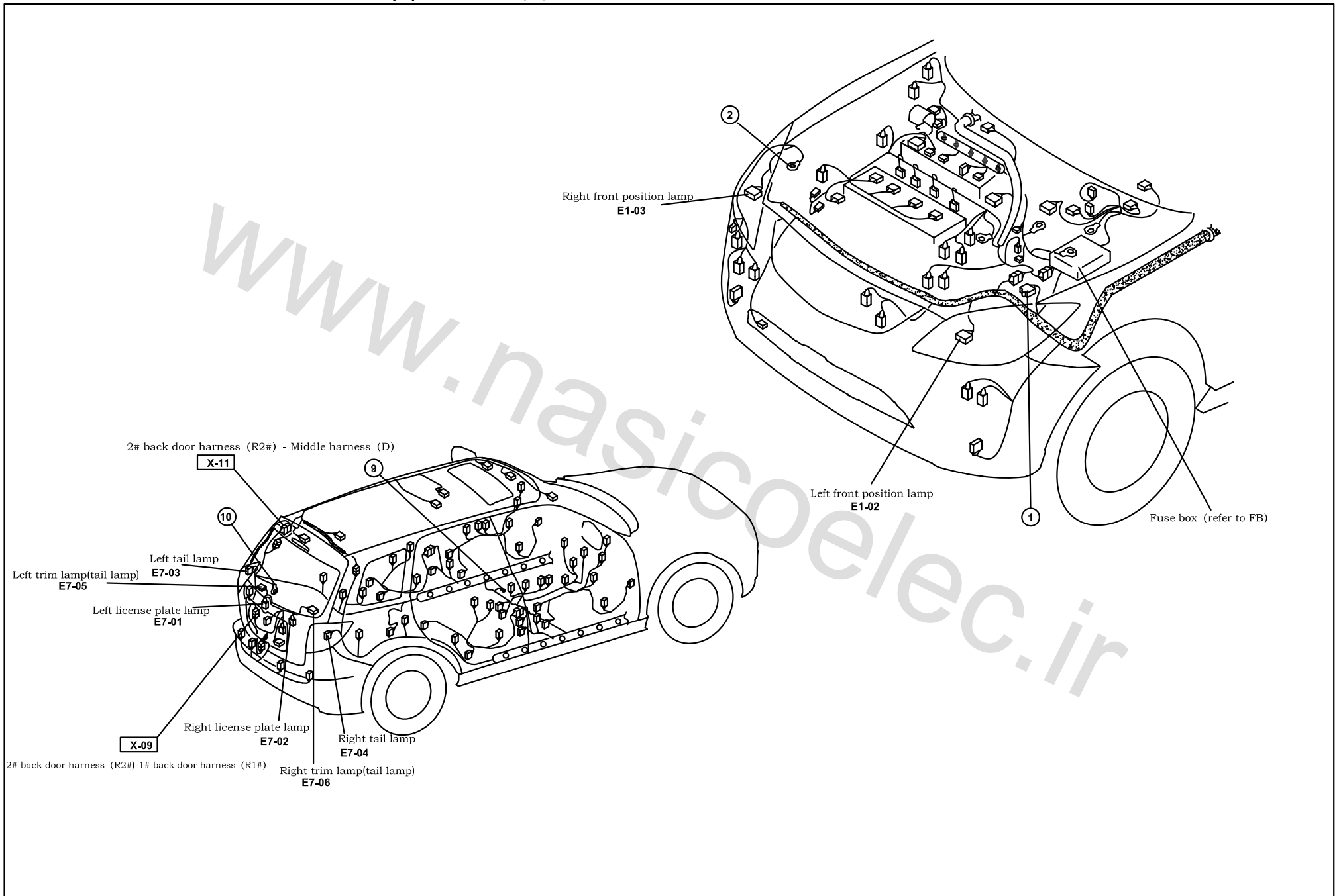

# Turn indicator and hazard warning lamp

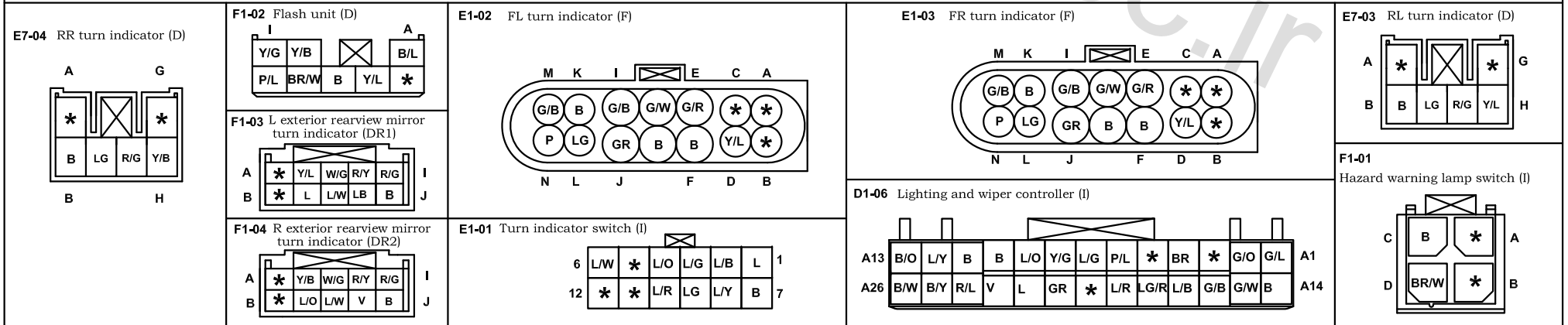
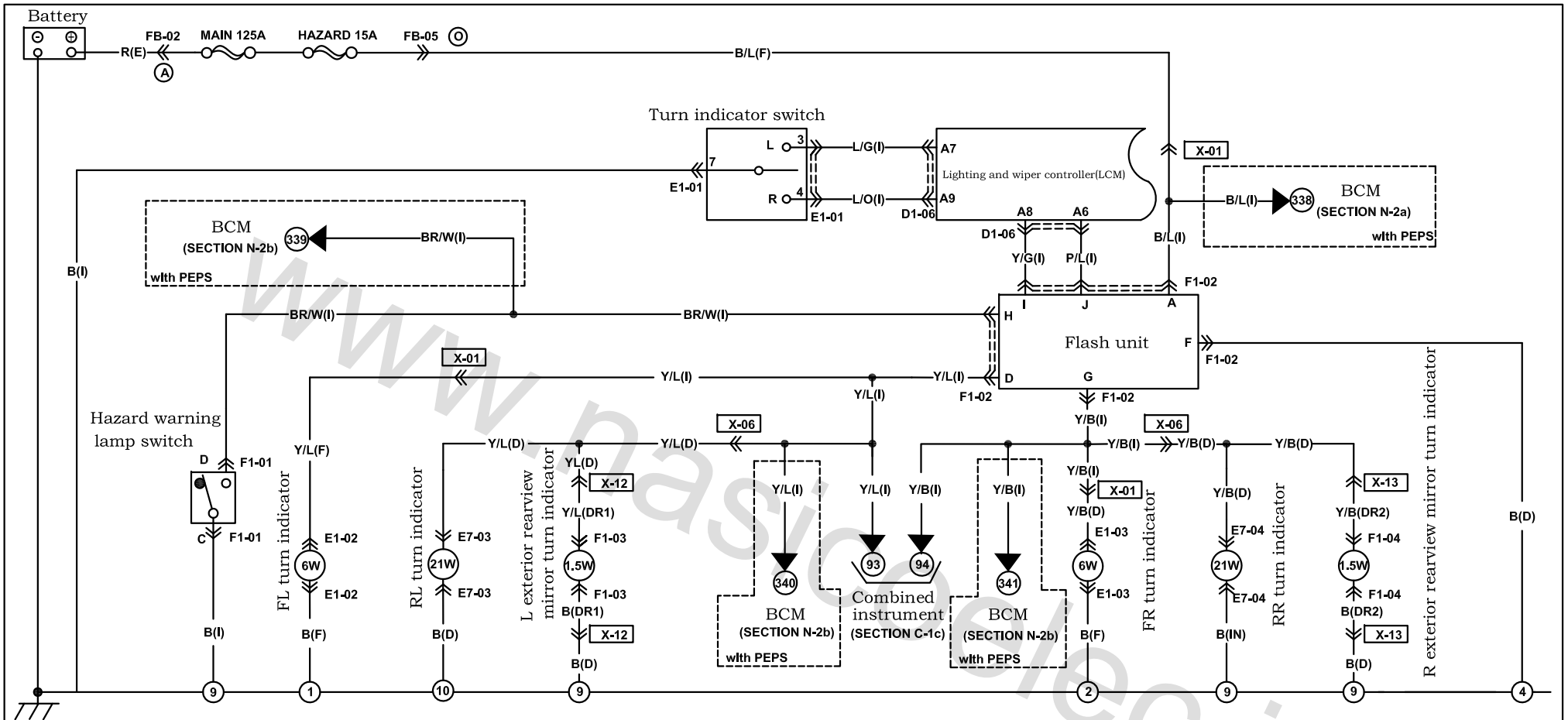

Harness mark:  (F)  (E)  (D)  (R)

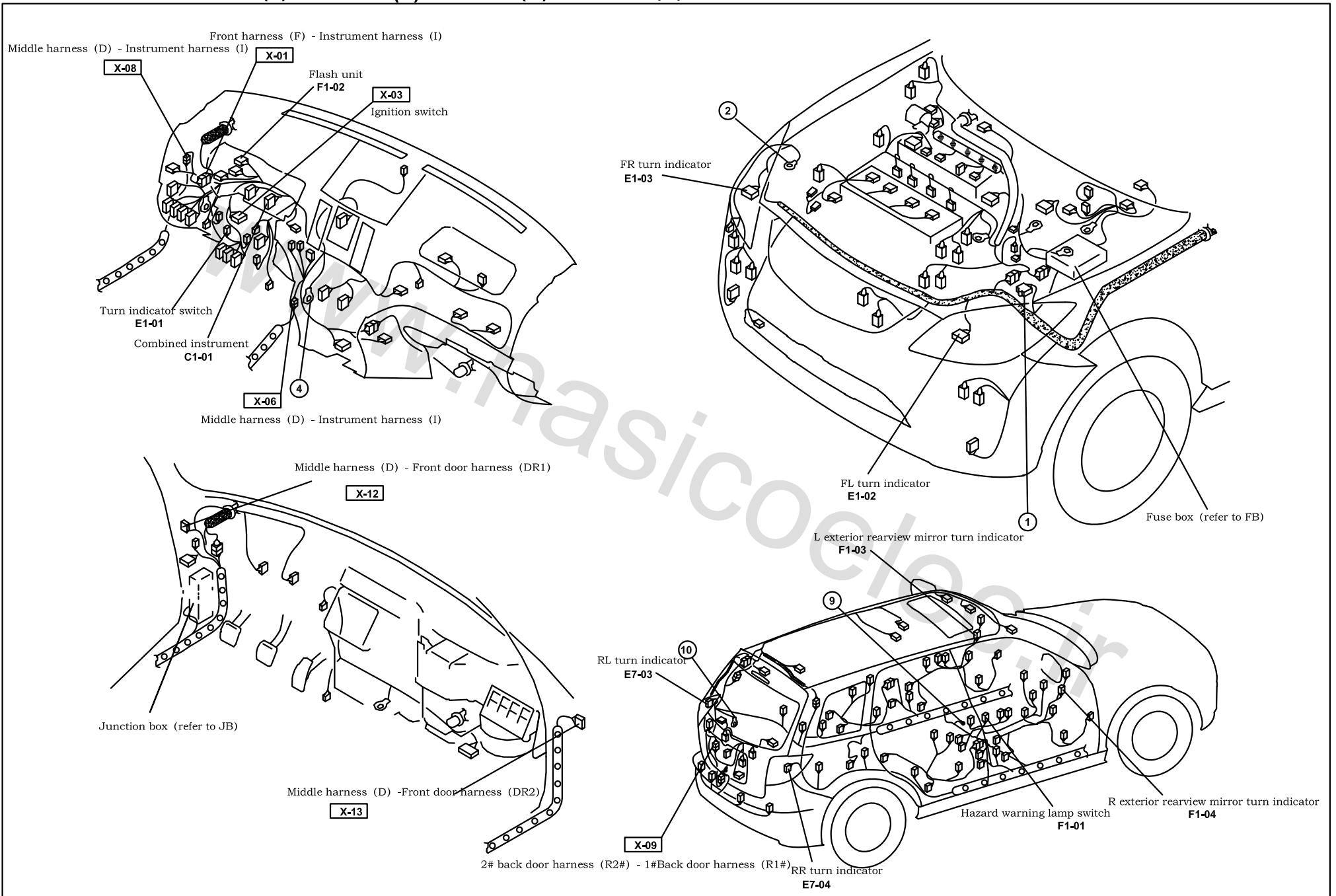

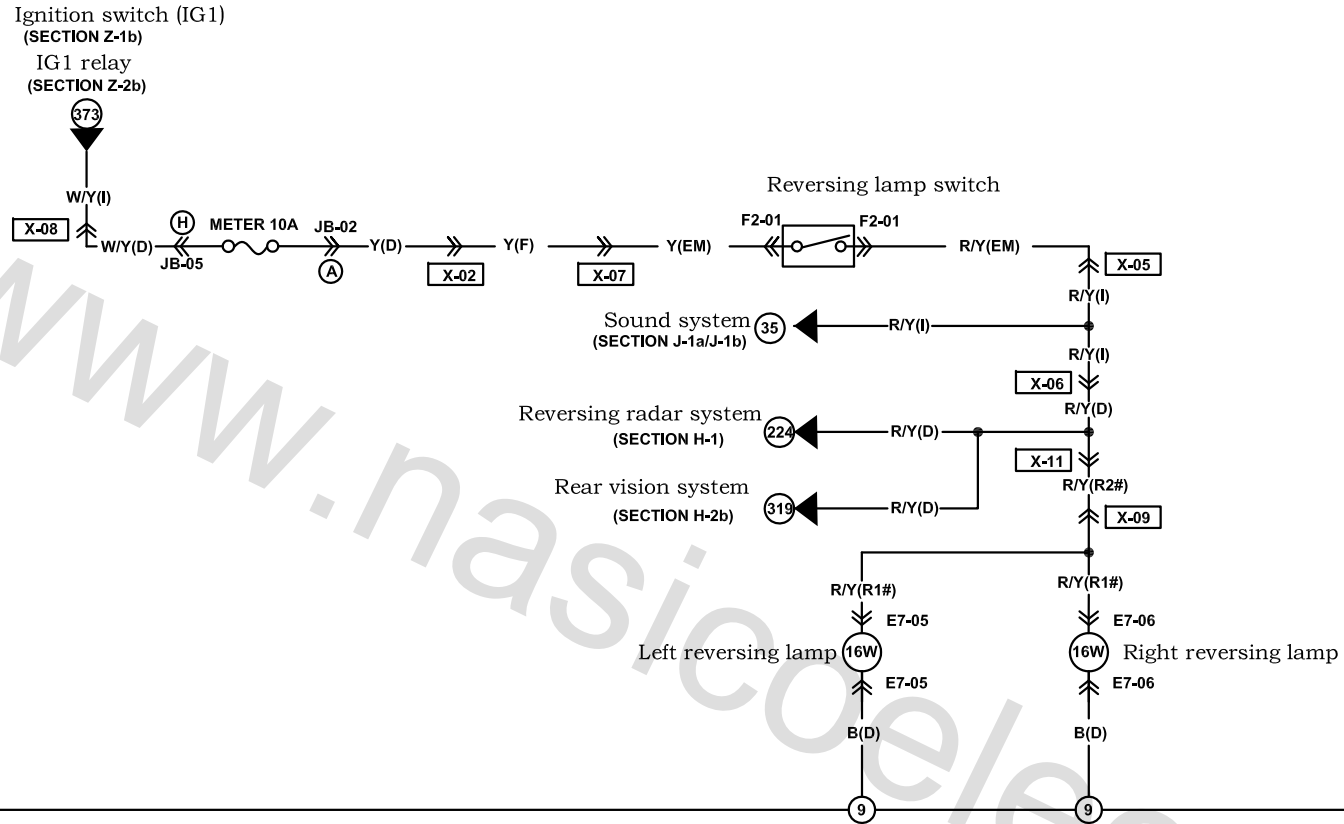

<b>F2-01</b> Reversing lamp switch (EM) 	<b>E7-05</b> Left trim lamp(tail lamp)(R2#) 	<b>E7-06</b> Right trim lamp(tail lamp)(R2#) 				



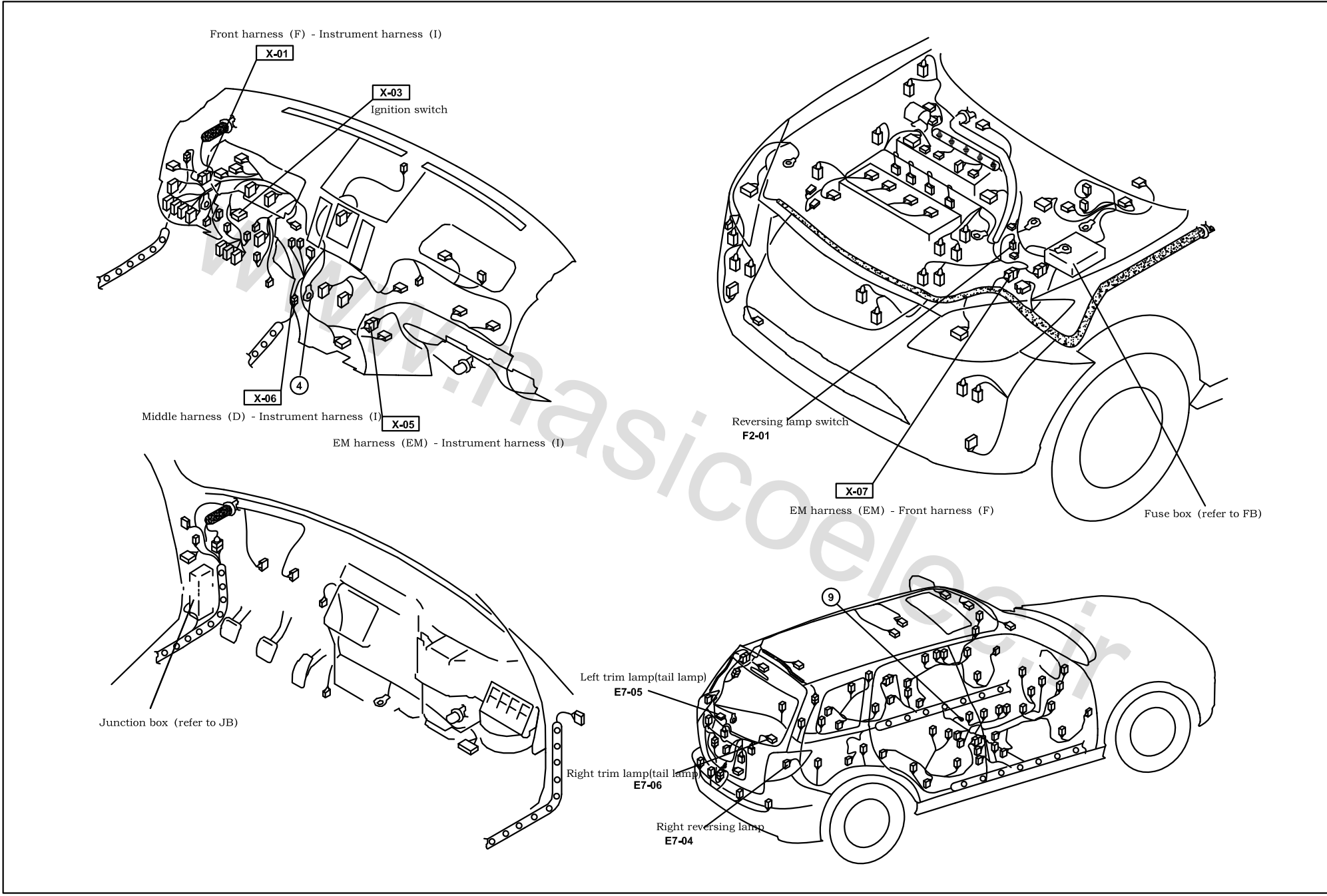

Harness mark:  (F)  (E)  (D)  (R)

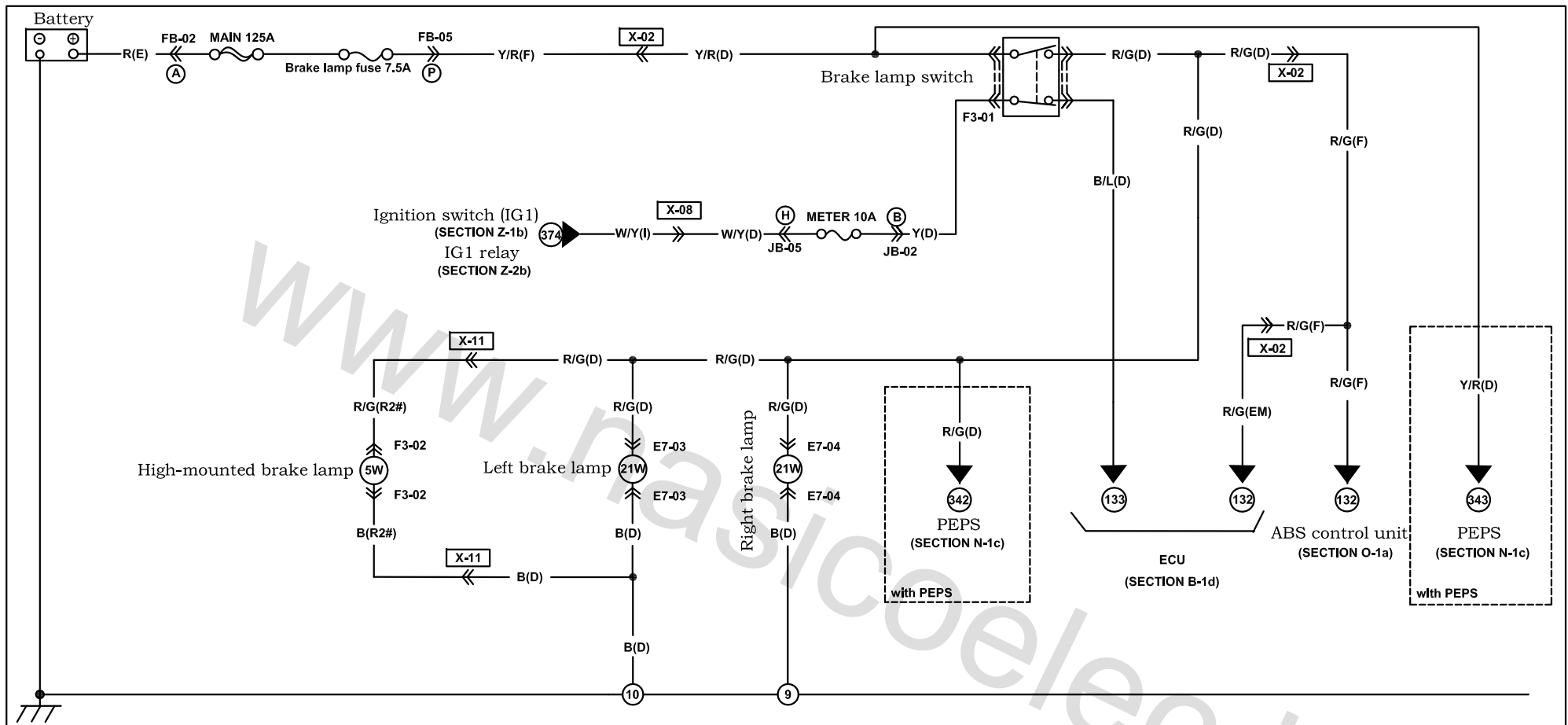



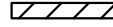

<p><b>F3-01</b> Brake switch (D)</p>	<p><b>F3-02</b> High-mounted brake lamp(R2#)</p>					
<p><b>E7-03</b> Left brake lamp(D)</p>	<p><b>E7-04</b> Right brake lamp(D)</p>					

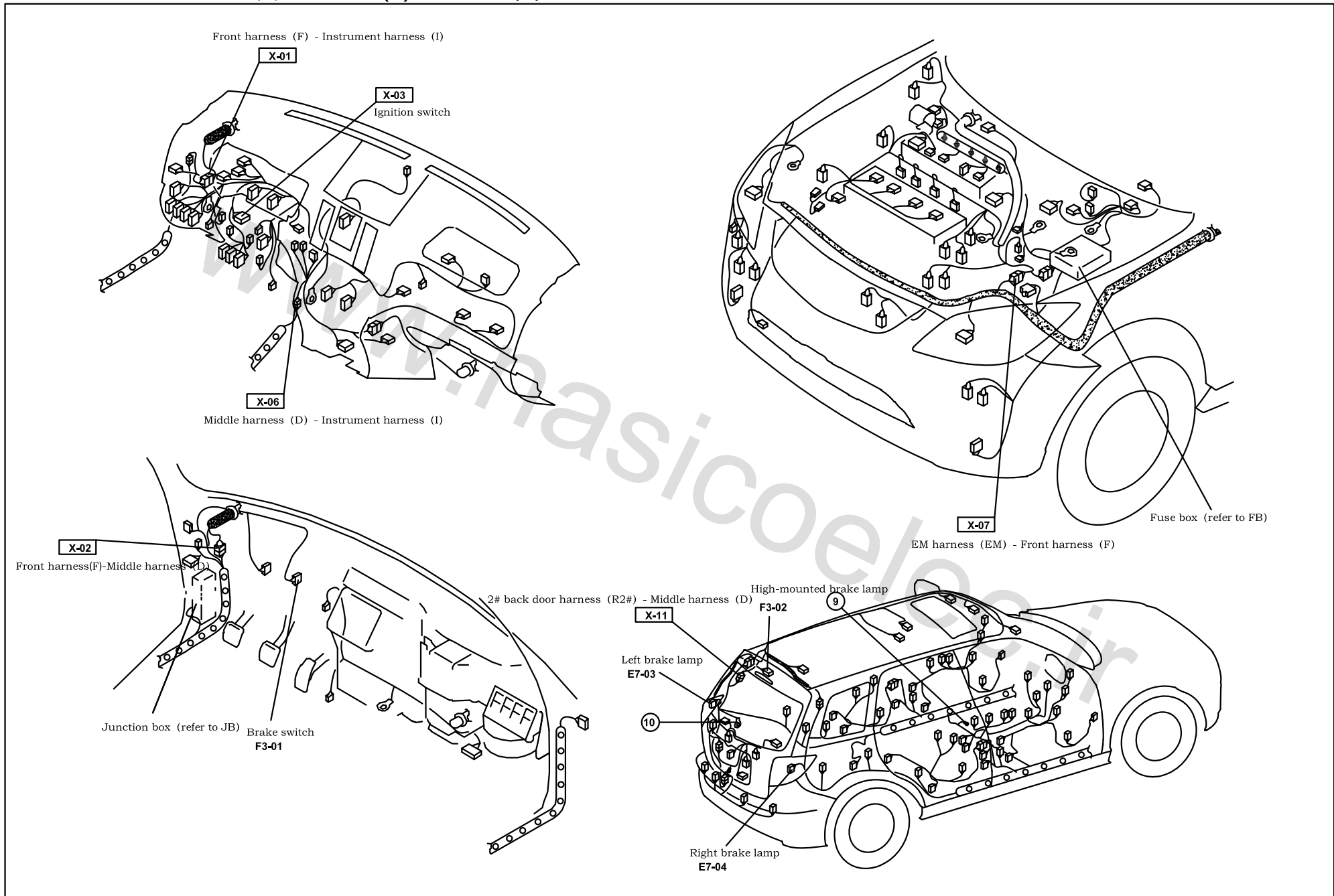
Harness mark:  (F)  (E)  (D)  (R)

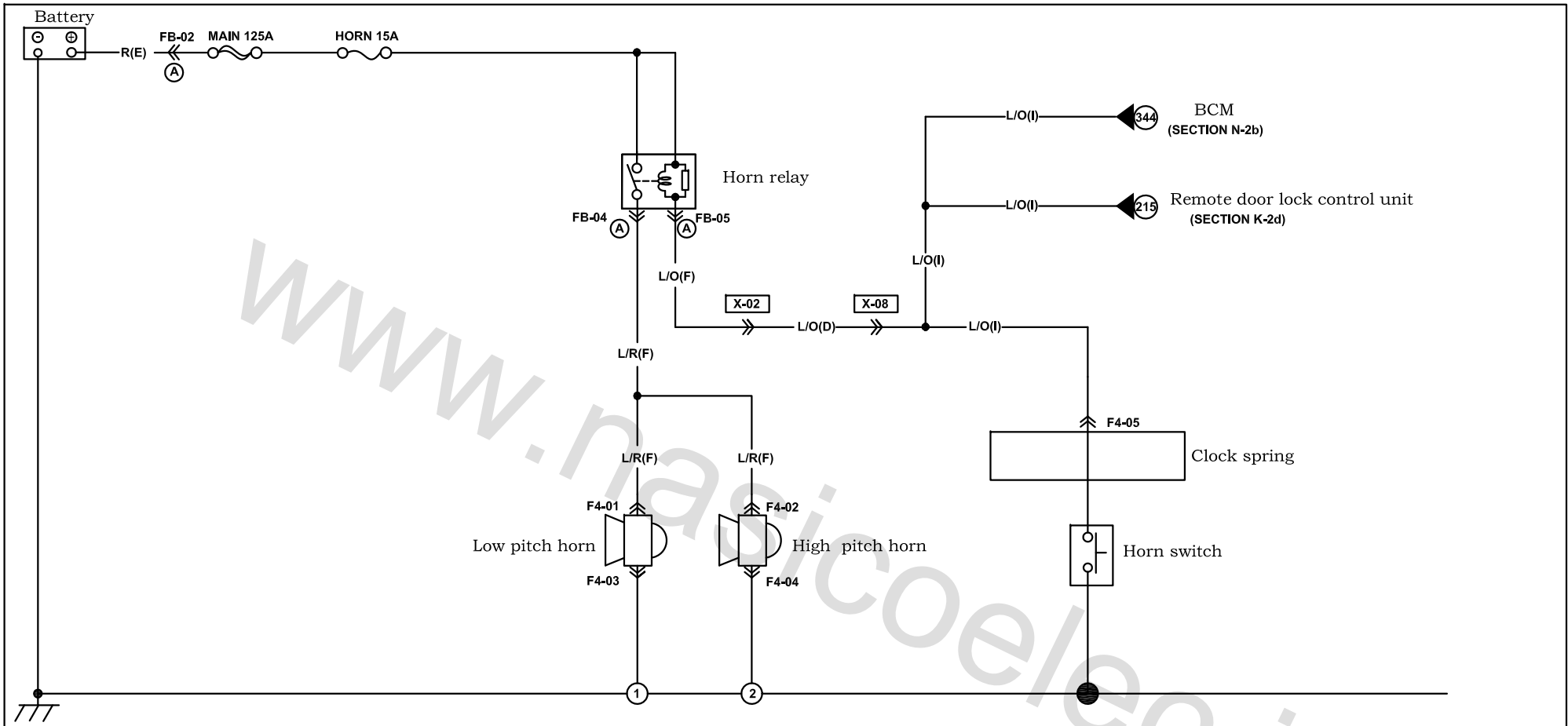

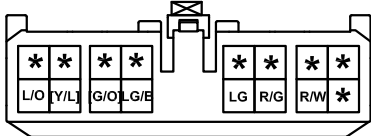

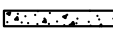
<p><b>F4-01</b> Low pitch horn (F)</p> <p>L/R <input type="checkbox"/></p>	<p><b>F4-02</b> High pitch horn(F)</p> <p>L/R <input type="checkbox"/></p>	<p><b>F4-05</b> Clock spring ( 1 ) <input type="checkbox"/> With cruise</p> 		
<p><b>F4-03</b> Low pitch horn (F)</p> <p>B <input type="checkbox"/></p>	<p><b>F4-04</b> High pitch horn(F)</p> <p>B <input type="checkbox"/></p>			

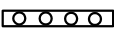
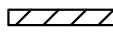
Harness mark:  (F)  (E)  (D)  (R)

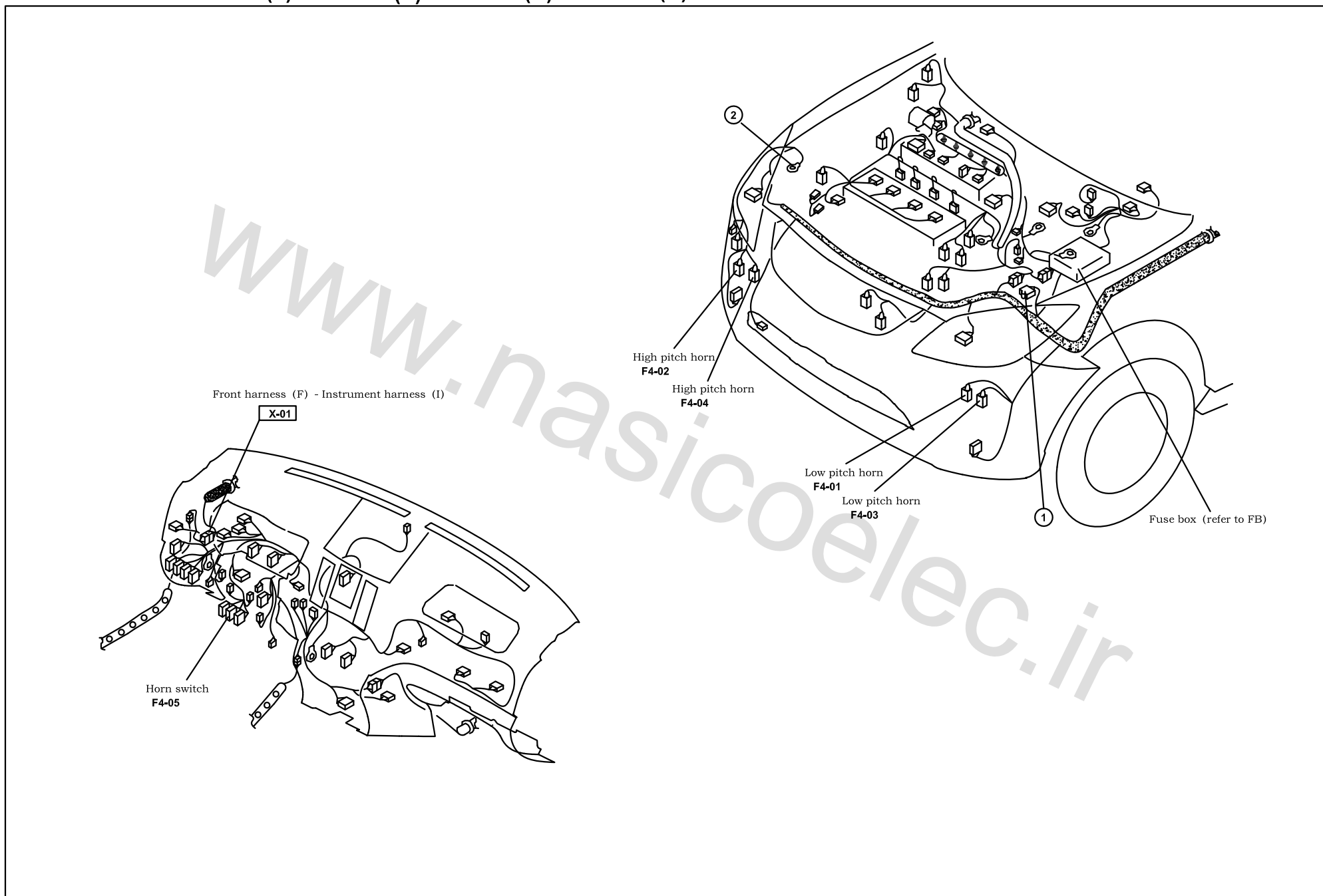

# Air conditioning system

G-1a

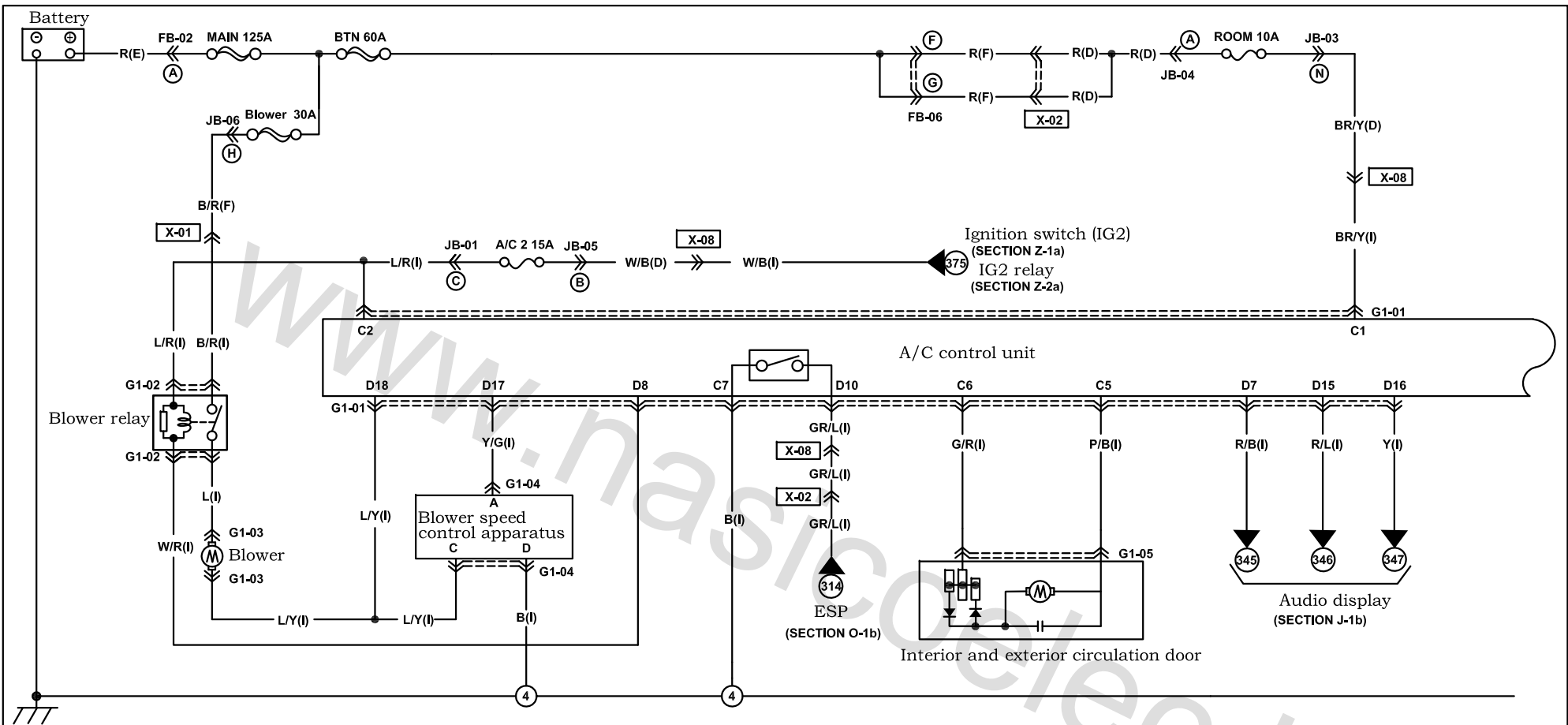

<p><b>G1-01</b> A/C control unit (I)</p> <p>( ) with ESP</p> <table border="1" style="width: 100%; text-align: center;"> <tr> <td colspan="3">C1</td> <td colspan="3">C6</td> </tr> <tr> <td>BR/Y</td> <td>L/R</td> <td>Y/R</td> <td>Y/L</td> <td>P/B</td> <td>G/R</td> </tr> <tr> <td>B</td> <td>W</td> <td>W/B</td> <td>W/G</td> <td>G</td> <td>B/W</td> </tr> <tr> <td colspan="3">C7</td> <td colspan="3">C12</td> </tr> </table> <table border="1" style="width: 100%; text-align: center;"> <tr> <td colspan="3">D1</td> <td colspan="3">D10</td> </tr> <tr> <td>LG</td> <td>L/R</td> <td>L/W</td> <td>R/G</td> <td>L</td> <td>O</td> <td>R/B</td> <td>W/R</td> <td>*</td> <td>GR/L</td> </tr> <tr> <td>LG/B</td> <td>V</td> <td>Y/B</td> <td>WL</td> <td>R/L</td> <td>Y</td> <td>Y/G</td> <td>L/Y</td> <td>*</td> <td>*</td> </tr> <tr> <td colspan="3">D11</td> <td colspan="3">D20</td> </tr> </table>	C1			C6			BR/Y	L/R	Y/R	Y/L	P/B	G/R	B	W	W/B	W/G	G	B/W	C7			C12			D1			D10			LG	L/R	L/W	R/G	L	O	R/B	W/R	*	GR/L	LG/B	V	Y/B	WL	R/L	Y	Y/G	L/Y	*	*	D11			D20			<p><b>G1-02</b> Blower relay (I)</p>	<p><b>G1-03</b> Blower (I)</p>	<p><b>G1-04</b> Blower speed control apparatus(I)</p>	
C1			C6																																																									
BR/Y	L/R	Y/R	Y/L	P/B	G/R																																																							
B	W	W/B	W/G	G	B/W																																																							
C7			C12																																																									
D1			D10																																																									
LG	L/R	L/W	R/G	L	O	R/B	W/R	*	GR/L																																																			
LG/B	V	Y/B	WL	R/L	Y	Y/G	L/Y	*	*																																																			
D11			D20																																																									
		<p><b>G1-05</b> Interior and exterior circulation door (I)</p>																																																										

Harness mark:  (F)  (E)  (D)  (R)

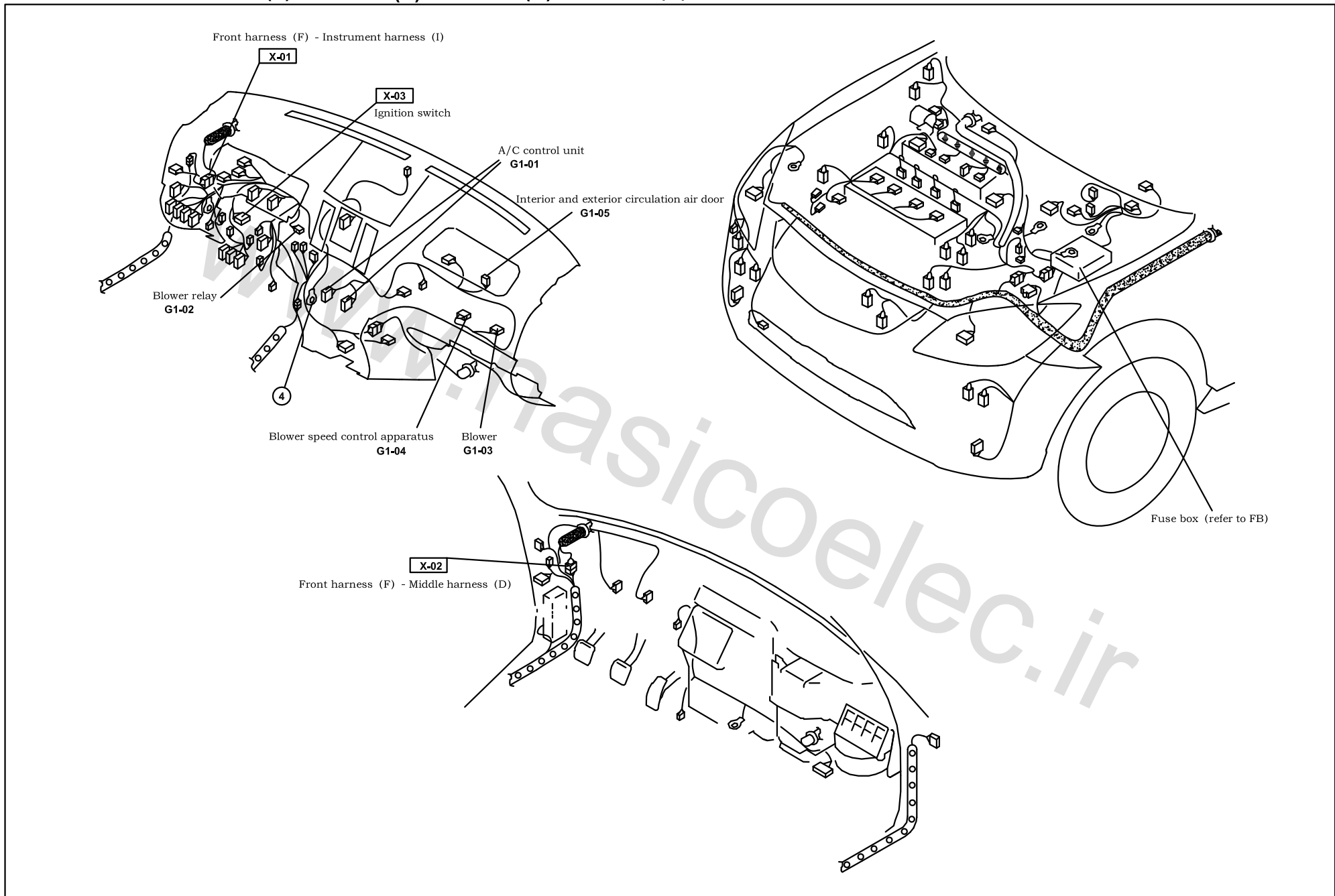

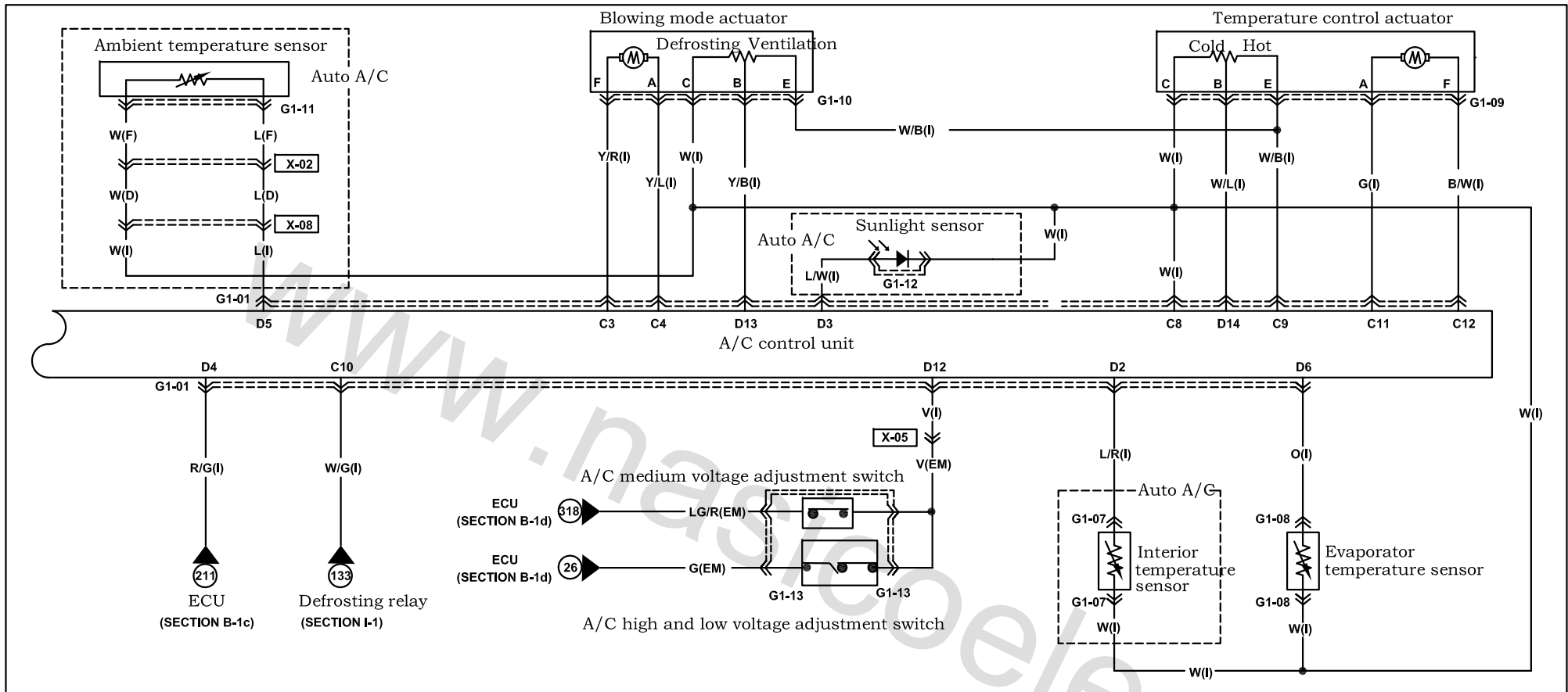

<p><b>G1-01</b> A/C control unit (I)</p> <p>( ) with ESP</p> <table border="1" style="width: 100%;"> <tr> <td style="width: 50%;"> <table border="1"> <tr><td>C1</td><td>BR/Y</td><td>L/R</td><td>Y/R</td><td>Y/L</td><td>P/B</td><td>G/R</td></tr> <tr><td>C6</td><td>B</td><td>W</td><td>W/B</td><td>W/G</td><td>G</td><td>B/W</td></tr> <tr><td>C7</td><td></td><td></td><td></td><td></td><td></td><td>C12</td></tr> </table> </td> <td style="width: 50%;"> <table border="1"> <tr><td>D1</td><td>LG</td><td>L/R</td><td>L/W</td><td>R/G</td><td>L</td><td>O</td><td>R/B</td><td>W/R</td><td>*</td><td>GR/L</td></tr> <tr><td>D10</td><td>LG/B</td><td>V</td><td>Y/B</td><td>W/L</td><td>R/L</td><td>Y</td><td>Y/G</td><td>L/Y</td><td>*</td><td>*</td></tr> <tr><td>D11</td><td></td><td></td><td></td><td></td><td></td><td></td><td></td><td></td><td></td><td>D20</td></tr> </table> </td> </tr> </table>	<table border="1"> <tr><td>C1</td><td>BR/Y</td><td>L/R</td><td>Y/R</td><td>Y/L</td><td>P/B</td><td>G/R</td></tr> <tr><td>C6</td><td>B</td><td>W</td><td>W/B</td><td>W/G</td><td>G</td><td>B/W</td></tr> <tr><td>C7</td><td></td><td></td><td></td><td></td><td></td><td>C12</td></tr> </table>	C1	BR/Y	L/R	Y/R	Y/L	P/B	G/R	C6	B	W	W/B	W/G	G	B/W	C7						C12	<table border="1"> <tr><td>D1</td><td>LG</td><td>L/R</td><td>L/W</td><td>R/G</td><td>L</td><td>O</td><td>R/B</td><td>W/R</td><td>*</td><td>GR/L</td></tr> <tr><td>D10</td><td>LG/B</td><td>V</td><td>Y/B</td><td>W/L</td><td>R/L</td><td>Y</td><td>Y/G</td><td>L/Y</td><td>*</td><td>*</td></tr> <tr><td>D11</td><td></td><td></td><td></td><td></td><td></td><td></td><td></td><td></td><td></td><td>D20</td></tr> </table>	D1	LG	L/R	L/W	R/G	L	O	R/B	W/R	*	GR/L	D10	LG/B	V	Y/B	W/L	R/L	Y	Y/G	L/Y	*	*	D11										D20	<p><b>G1-07</b> Interior temperature sensor(I)</p>	<p><b>G1-08</b> Evaporator temperature sensor(I)</p>	<p><b>G1-09</b> Temperature control actuator (I)</p> <table border="1"> <tr><td>B/W</td><td>W/B</td><td>*</td><td>W</td><td>W/L</td><td>G</td></tr> <tr><td>F</td><td></td><td></td><td></td><td></td><td>A</td></tr> </table>	B/W	W/B	*	W	W/L	G	F					A	<p><b>G1-10</b> Blowing mode actuator (I)</p> <table border="1"> <tr><td>G</td><td>A</td></tr> <tr><td>W</td><td>*</td><td>W/B</td><td>*</td></tr> <tr><td>Y/L</td><td>Y/B</td><td>Y/R</td><td>*</td></tr> <tr><td>H</td><td></td><td></td><td>B</td></tr> </table>	G	A	W	*	W/B	*	Y/L	Y/B	Y/R	*	H			B
<table border="1"> <tr><td>C1</td><td>BR/Y</td><td>L/R</td><td>Y/R</td><td>Y/L</td><td>P/B</td><td>G/R</td></tr> <tr><td>C6</td><td>B</td><td>W</td><td>W/B</td><td>W/G</td><td>G</td><td>B/W</td></tr> <tr><td>C7</td><td></td><td></td><td></td><td></td><td></td><td>C12</td></tr> </table>	C1	BR/Y	L/R	Y/R	Y/L	P/B	G/R	C6	B	W	W/B	W/G	G	B/W	C7						C12	<table border="1"> <tr><td>D1</td><td>LG</td><td>L/R</td><td>L/W</td><td>R/G</td><td>L</td><td>O</td><td>R/B</td><td>W/R</td><td>*</td><td>GR/L</td></tr> <tr><td>D10</td><td>LG/B</td><td>V</td><td>Y/B</td><td>W/L</td><td>R/L</td><td>Y</td><td>Y/G</td><td>L/Y</td><td>*</td><td>*</td></tr> <tr><td>D11</td><td></td><td></td><td></td><td></td><td></td><td></td><td></td><td></td><td></td><td>D20</td></tr> </table>	D1	LG	L/R	L/W	R/G	L	O	R/B	W/R	*	GR/L	D10	LG/B	V	Y/B	W/L	R/L	Y	Y/G	L/Y	*	*	D11										D20																															
C1	BR/Y	L/R	Y/R	Y/L	P/B	G/R																																																																																
C6	B	W	W/B	W/G	G	B/W																																																																																
C7						C12																																																																																
D1	LG	L/R	L/W	R/G	L	O	R/B	W/R	*	GR/L																																																																												
D10	LG/B	V	Y/B	W/L	R/L	Y	Y/G	L/Y	*	*																																																																												
D11										D20																																																																												
B/W	W/B	*	W	W/L	G																																																																																	
F					A																																																																																	
G	A																																																																																					
W	*	W/B	*																																																																																			
Y/L	Y/B	Y/R	*																																																																																			
H			B																																																																																			
	<p><b>G1-11</b> Ambient temperature sensor(F)</p>	<p><b>G1-12</b> Sunlight sensor (I)</p>	<p><b>G1-13</b> A/C pressure switch (EM)</p>																																																																																			



Harness mark:  (F)  (E)  (D)  (R)

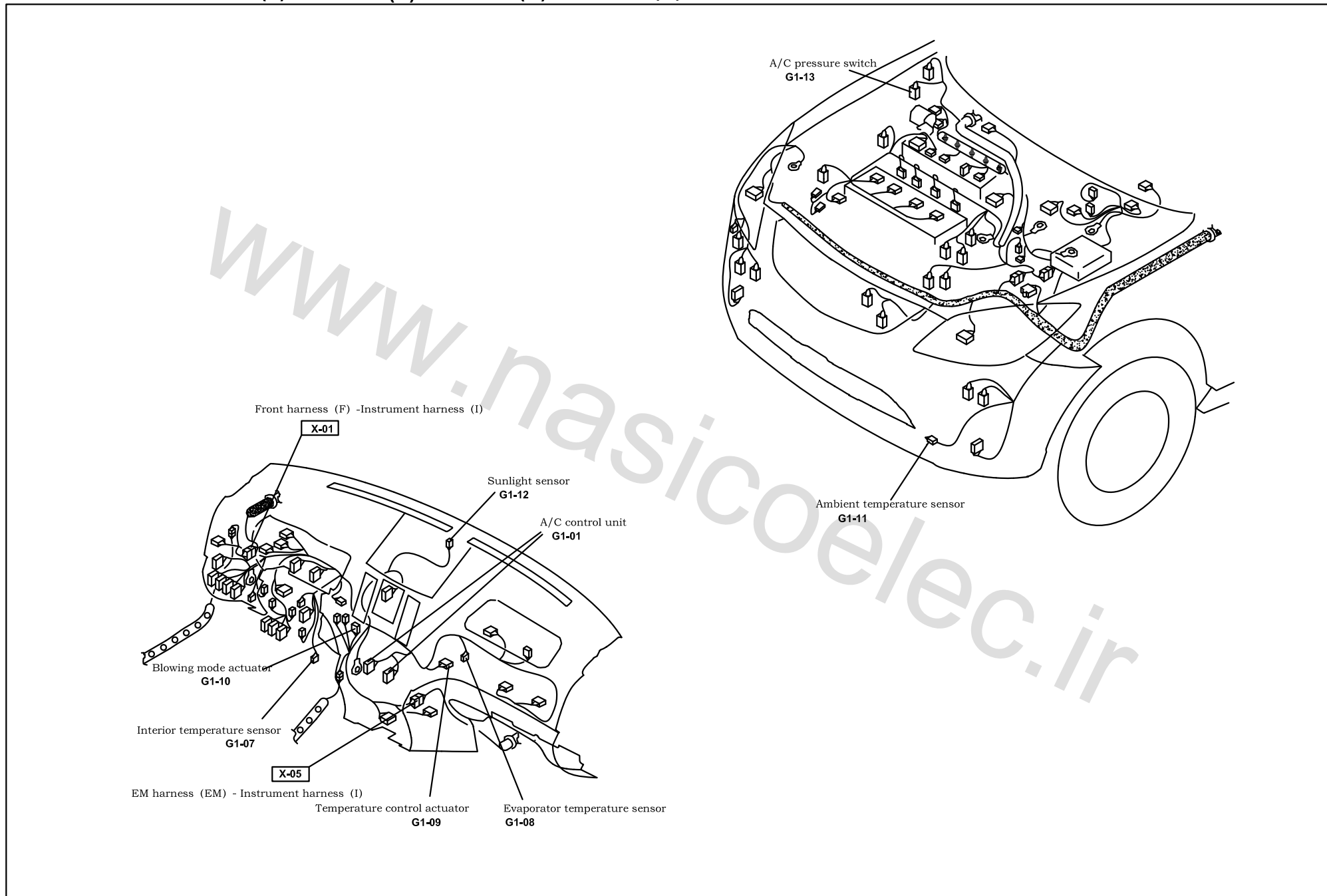

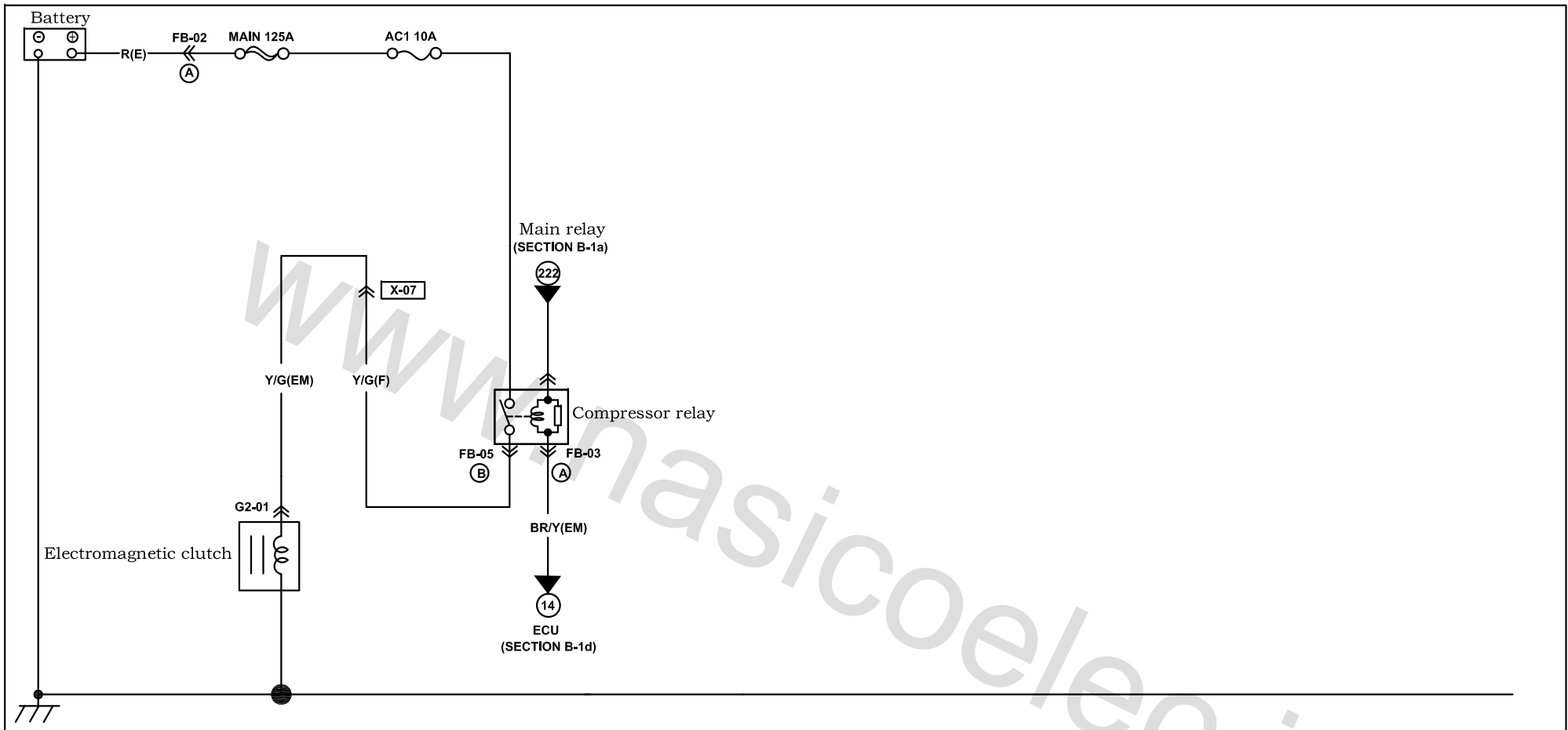

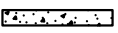
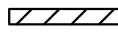

<p>G2-01 Electromagnetic clutch (EM)</p> 						

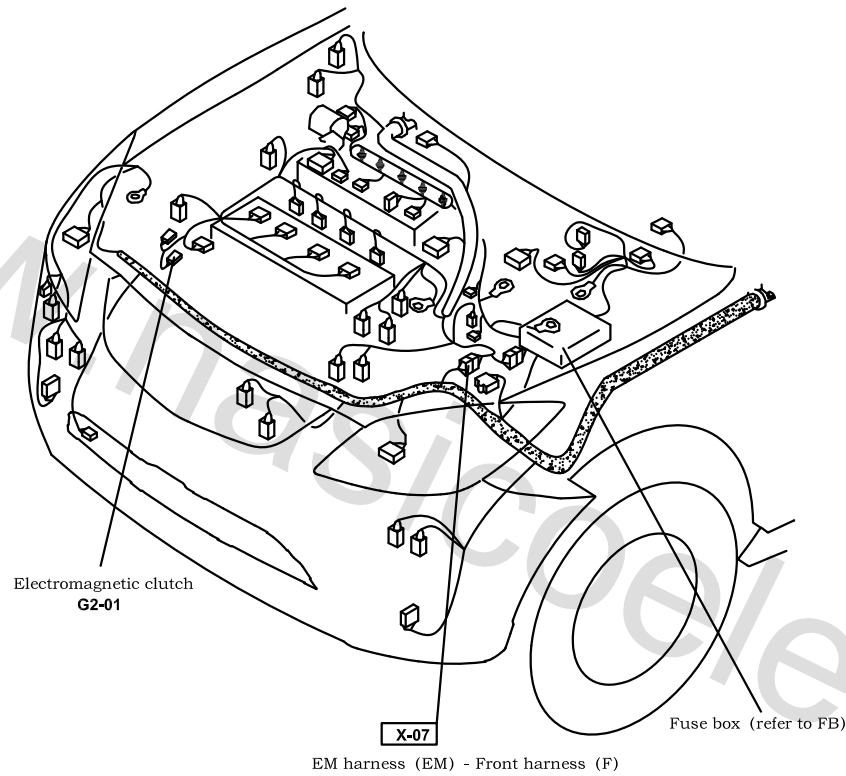
Harness mark:  (F)  (E)  (D)  (R)

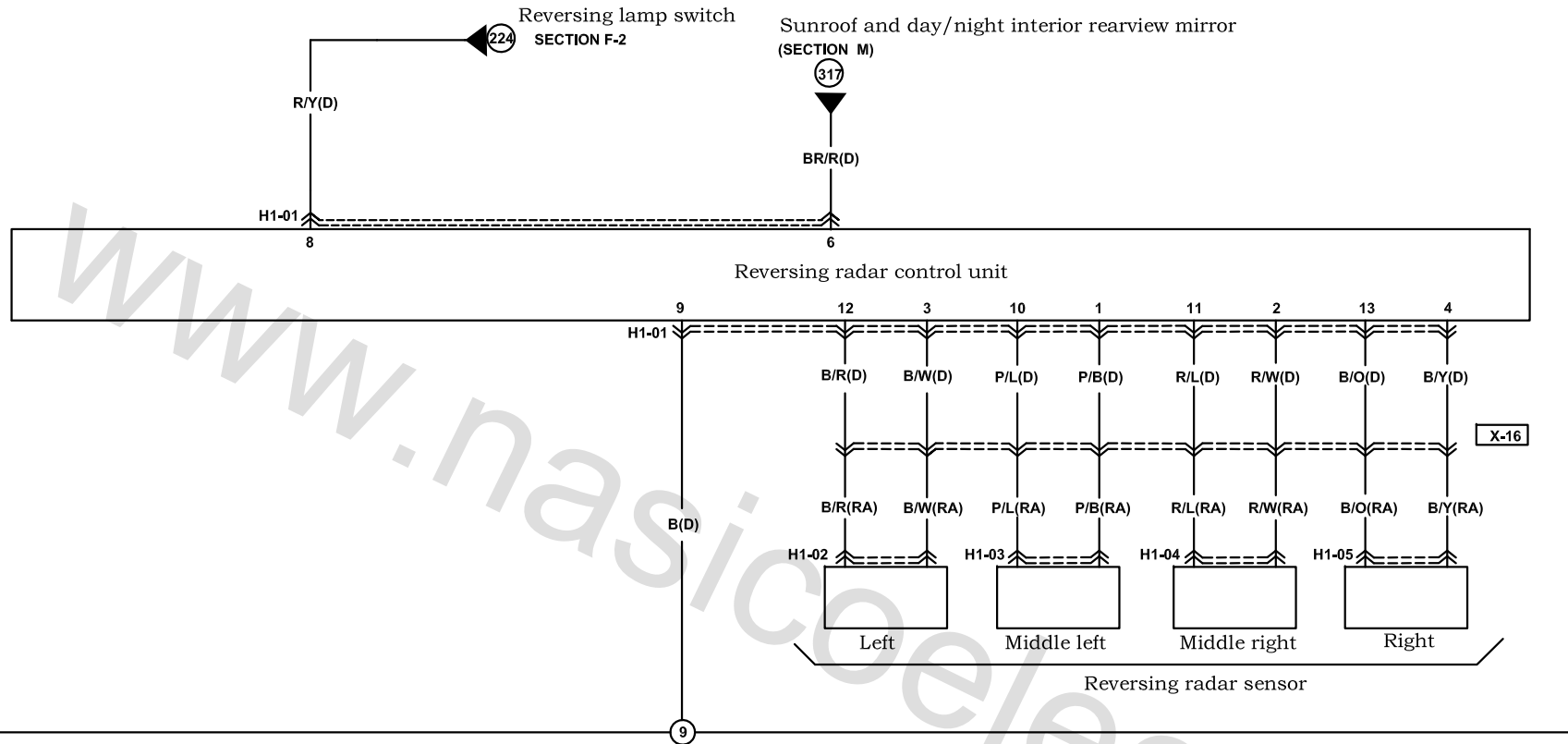



<p><b>H1-01</b> Reversing radar control unit (IN)</p> <table border="1" style="margin-left: auto; margin-right: auto;"> <tr> <td style="text-align: center;">1</td> <td style="text-align: center;">8</td> </tr> <tr> <td style="text-align: center;">P/B</td> <td style="text-align: center;">R/Y</td> </tr> <tr> <td style="text-align: center;">R/W</td> <td style="text-align: center;">*</td> </tr> <tr> <td style="text-align: center;">B/W</td> <td style="text-align: center;">BR/R</td> </tr> <tr> <td style="text-align: center;">B/Y</td> <td style="text-align: center;">*</td> </tr> <tr> <td style="text-align: center;">*</td> <td style="text-align: center;">*</td> </tr> <tr> <td style="text-align: center;">BR/R</td> <td style="text-align: center;">*</td> </tr> <tr> <td style="text-align: center;">*</td> <td style="text-align: center;">*</td> </tr> <tr> <td style="text-align: center;">R/Y</td> <td style="text-align: center;">*</td> </tr> <tr> <td style="text-align: center;">B</td> <td style="text-align: center;">*</td> </tr> <tr> <td style="text-align: center;">P/L</td> <td style="text-align: center;">*</td> </tr> <tr> <td style="text-align: center;">R/L</td> <td style="text-align: center;">*</td> </tr> <tr> <td style="text-align: center;">B/R</td> <td style="text-align: center;">*</td> </tr> <tr> <td style="text-align: center;">B/O</td> <td style="text-align: center;">*</td> </tr> <tr> <td style="text-align: center;">9</td> <td style="text-align: center;">16</td> </tr> </table>	1	8	P/B	R/Y	R/W	*	B/W	BR/R	B/Y	*	*	*	BR/R	*	*	*	R/Y	*	B	*	P/L	*	R/L	*	B/R	*	B/O	*	9	16	<p><b>H1-02</b> Left reversing radar sensor (RA)</p> <table border="1" style="margin-left: auto; margin-right: auto;"> <tr> <td style="text-align: center;">B/R</td> <td style="text-align: center;">B/W</td> </tr> </table>	B/R	B/W	<p><b>H1-03</b> Middle left reversing radar sensor (RA)</p> <table border="1" style="margin-left: auto; margin-right: auto;"> <tr> <td style="text-align: center;">P/L</td> <td style="text-align: center;">P/B</td> </tr> </table>	P/L	P/B	<p><b>H1-04</b> Middle right reversing radar sensor (RA)</p> <table border="1" style="margin-left: auto; margin-right: auto;"> <tr> <td style="text-align: center;">R/L</td> <td style="text-align: center;">R/W</td> </tr> </table>	R/L	R/W	<p><b>H1-05</b> Right reversing radar sensor (RA)</p> <table border="1" style="margin-left: auto; margin-right: auto;"> <tr> <td style="text-align: center;">B/O</td> <td style="text-align: center;">B/Y</td> </tr> </table>	B/O	B/Y	
1	8																																										
P/B	R/Y																																										
R/W	*																																										
B/W	BR/R																																										
B/Y	*																																										
*	*																																										
BR/R	*																																										
*	*																																										
R/Y	*																																										
B	*																																										
P/L	*																																										
R/L	*																																										
B/R	*																																										
B/O	*																																										
9	16																																										
B/R	B/W																																										
P/L	P/B																																										
R/L	R/W																																										
B/O	B/Y																																										

Harness mark:  (F)  (E)  (D)  (R)

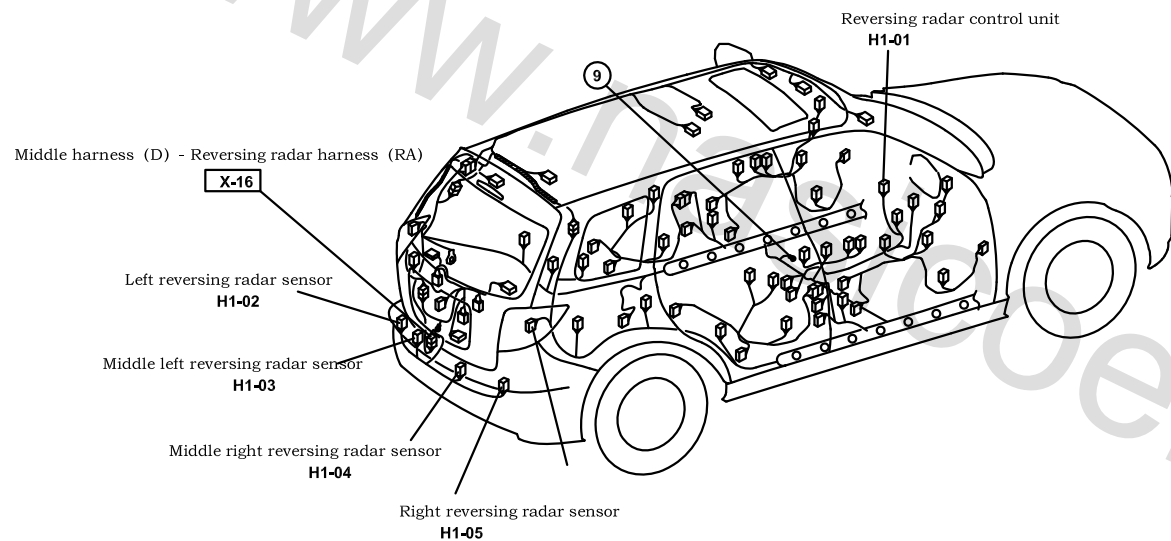

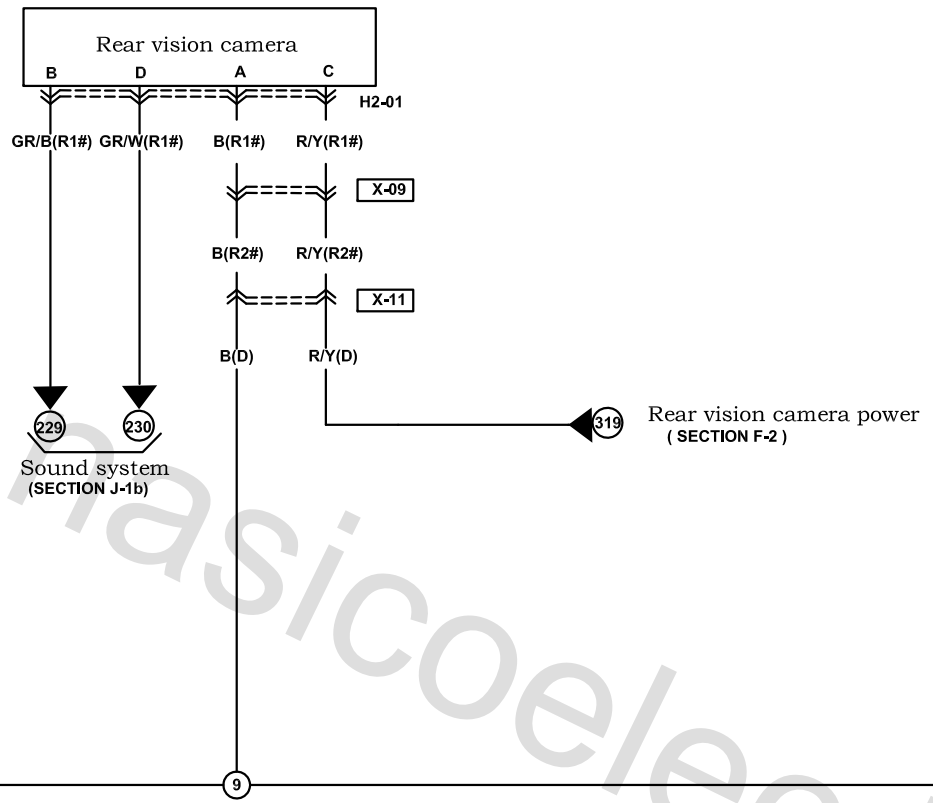

///

H2-01 Rear vision camera (R1#)

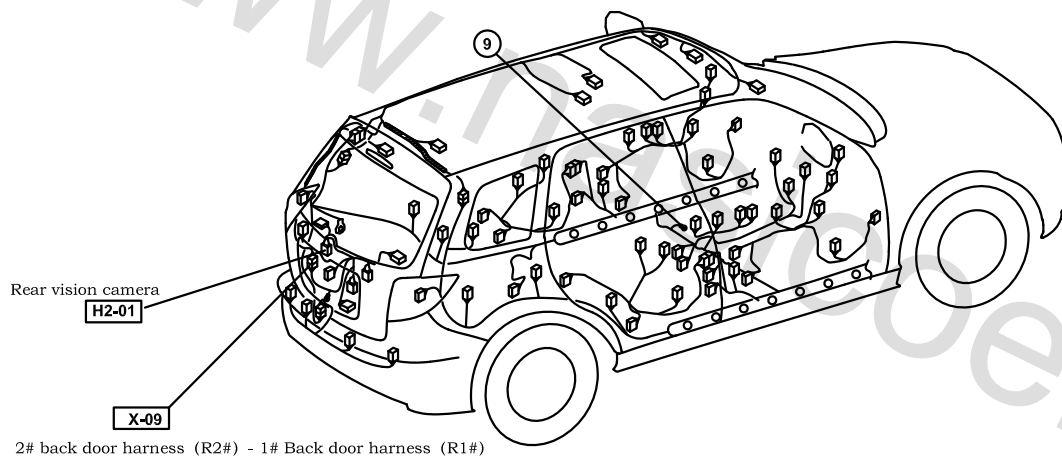

C	<input checked="" type="checkbox"/>	A
R/Y		B
GR/W		GR/B
D		B

Harness mark:  (F)  (E)  (D)  (R)

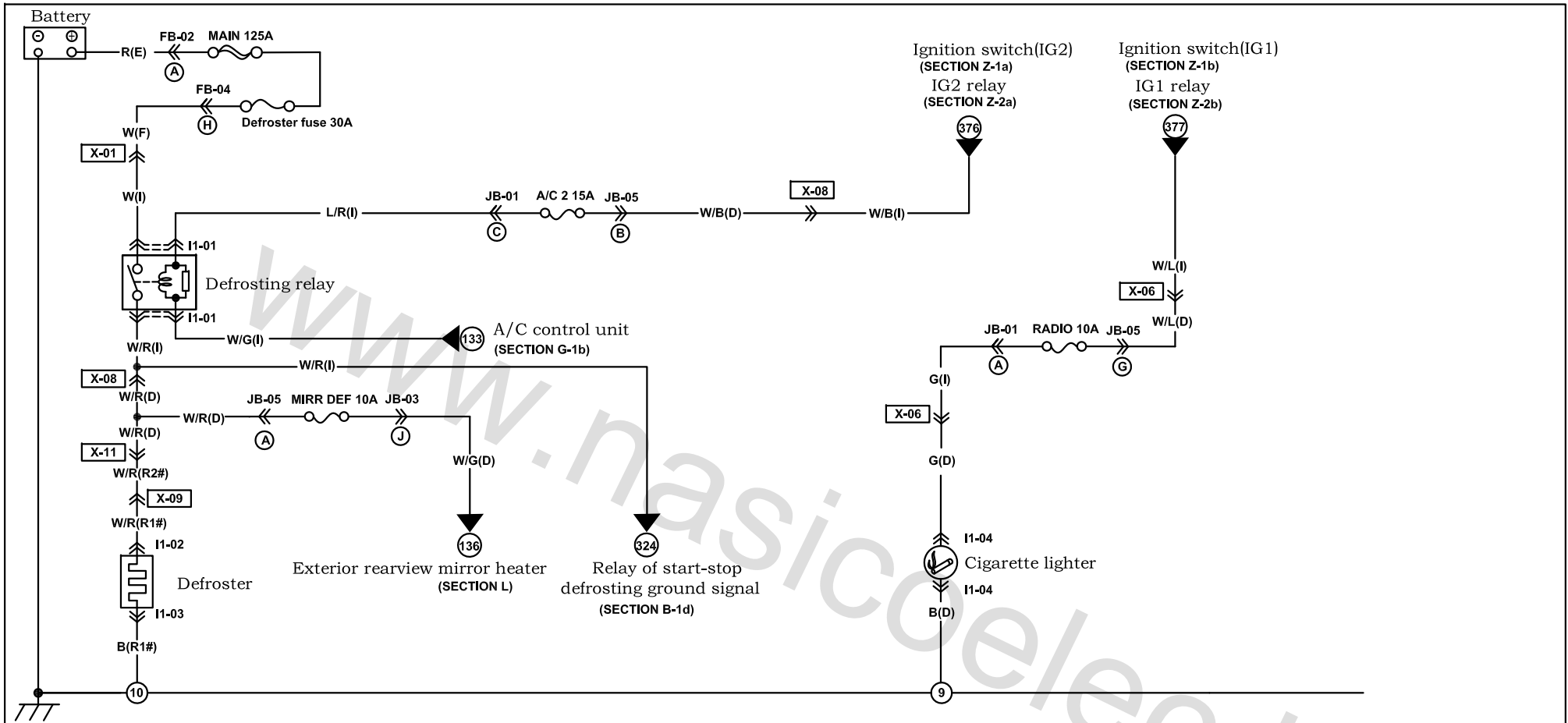

2# back door harness (R2#) - 1# Back door harness (R1#)

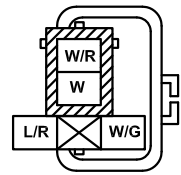

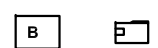
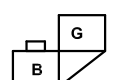
<p><b>I1-01</b> Defrosting relay (I)</p> 	<p><b>I1-02</b> Defroster (R1#)</p> 	<p><b>I1-03</b> Defroster (R1#)</p> 	<p><b>I1-04</b> Cigarette lighter (I)</p> 		



Harness mark:  (F)  (E)  (D)  (R)

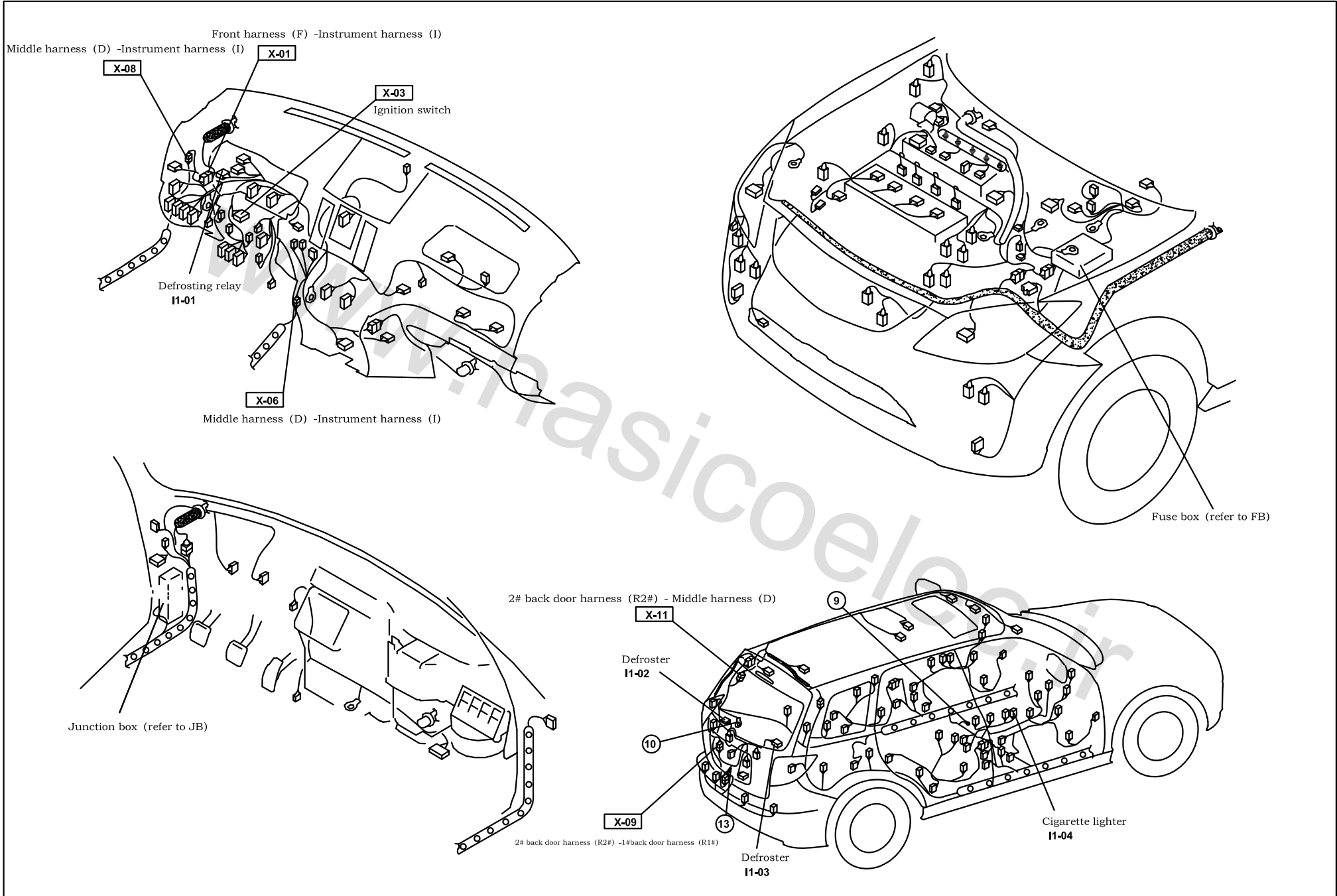

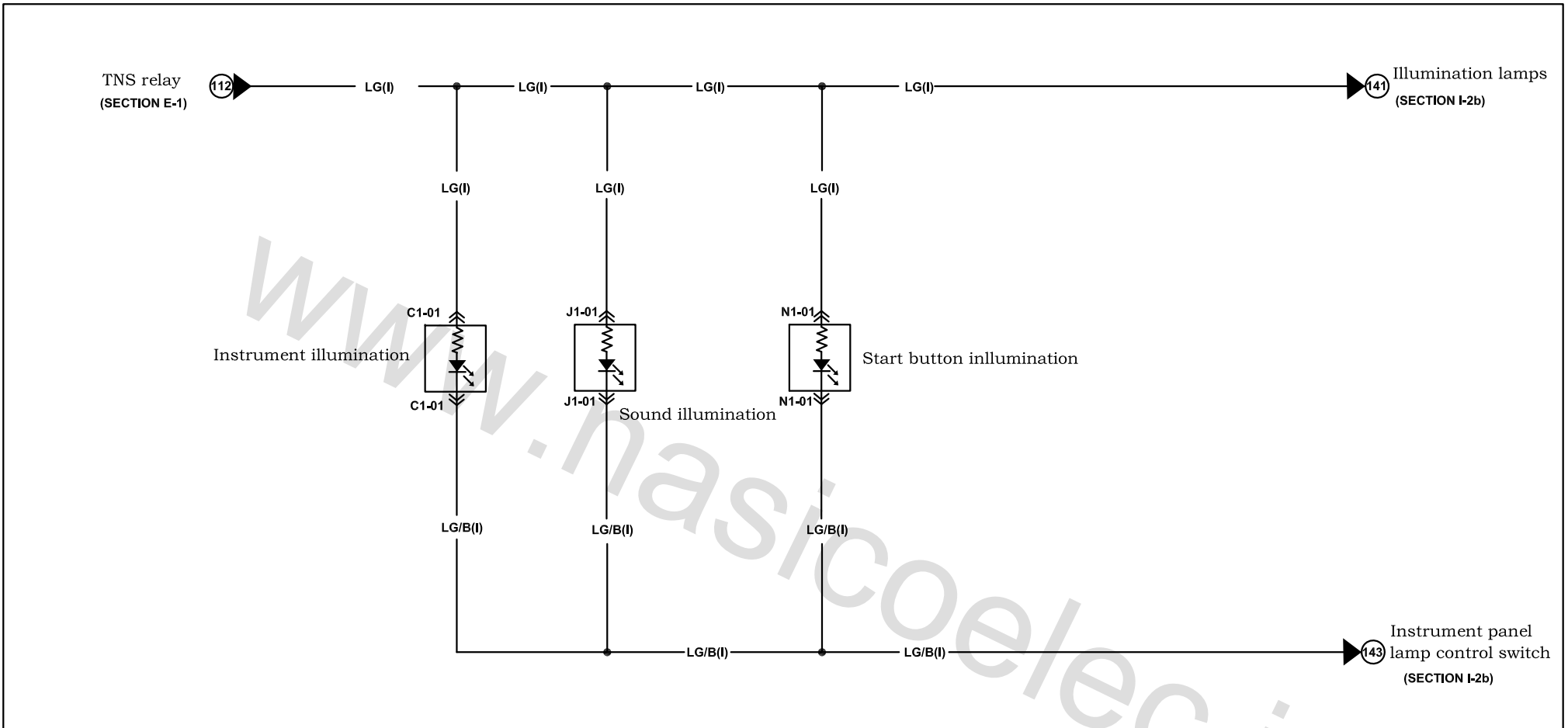

C1-01 Combined instrument (I) ( ) with ESP

A1	B/Y	B/L	B/W	B/R	R/Y	P	Y/G	(G/O)	(V/W)	*	*	*	*	*	*	A16
A17	LG	LG/B	*	*	*	*	*	*	*	*	*	G/B	LG/R	G/W	G/R	Y/L
A17																A32

J1-01 Sound unit (I)

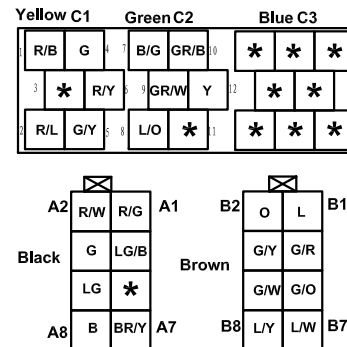

N1-01 Start button (I)

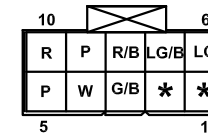

Harness mark:  (F)  (E)  (D)  (R)

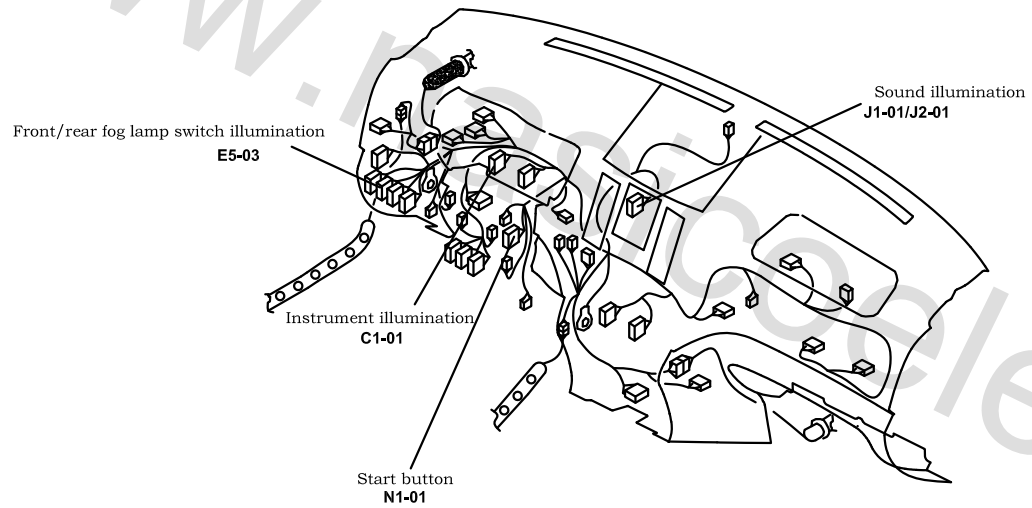

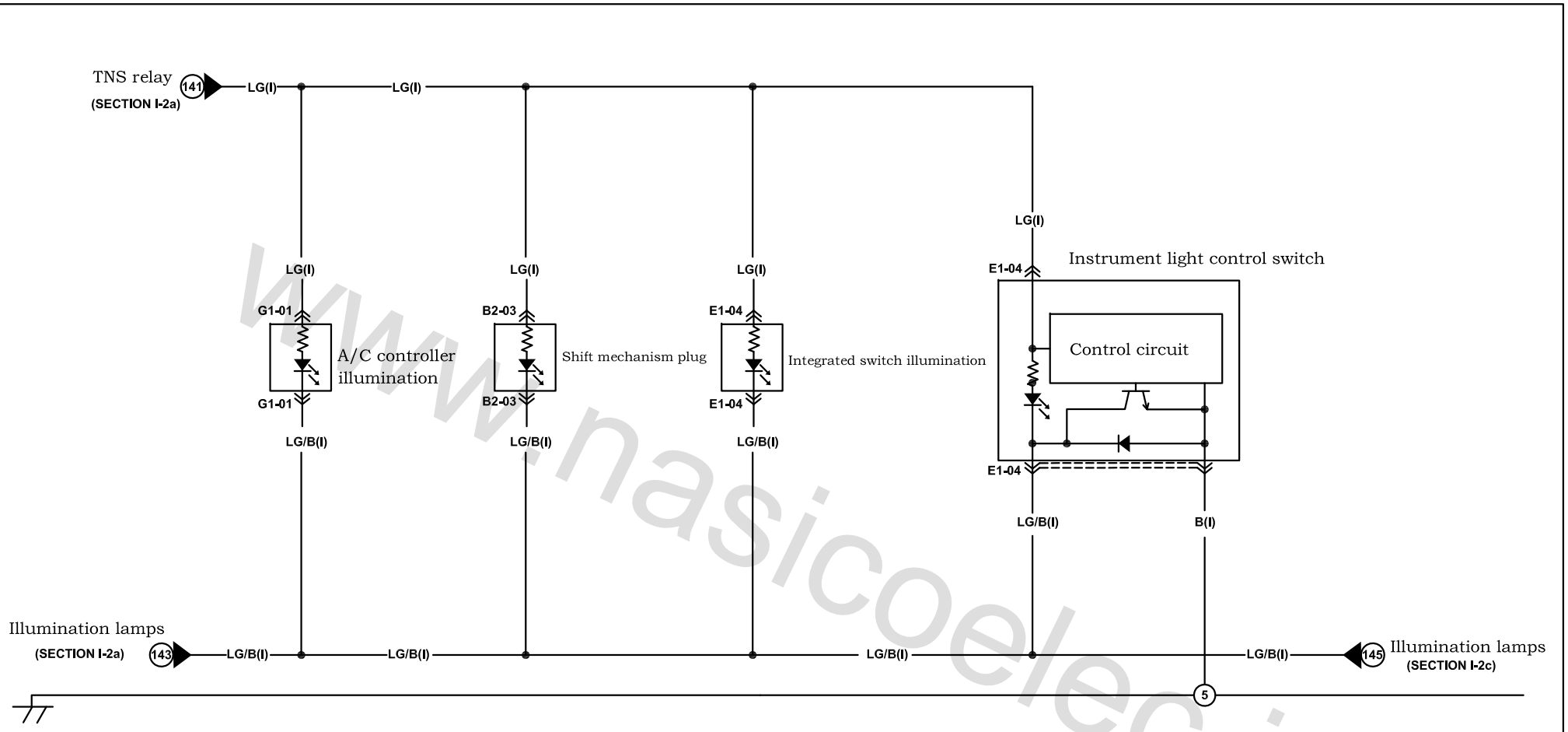

**G1-01** A/C controller illumination (I) ( ) with ESP

D1					⊗					D10
LG	L/R	L/W	R/G	L	O	R/B	W/R	*	GR/L	
LG/B	V	Y/B	W/L	R/L	Y	Y/G	L/Y	*	*	
D11										D20

**L1-01** Instrument light control switch (I)

				K	I					
S	Q	O	M	L	G	E	C	A		
R/B	LG	LG/B	L/W	L	L/O	L/B	V	R/G	R/Y	
B	P	G/B	&P/L	W	*	*	*	*	B	
T	R	P	N	L	J	H	F	D	B	



**B2-03** Shift mechanism plug (I)

G	LG			Y	B/Y	A
H	LG/B	*	G/R	*	O/B	B

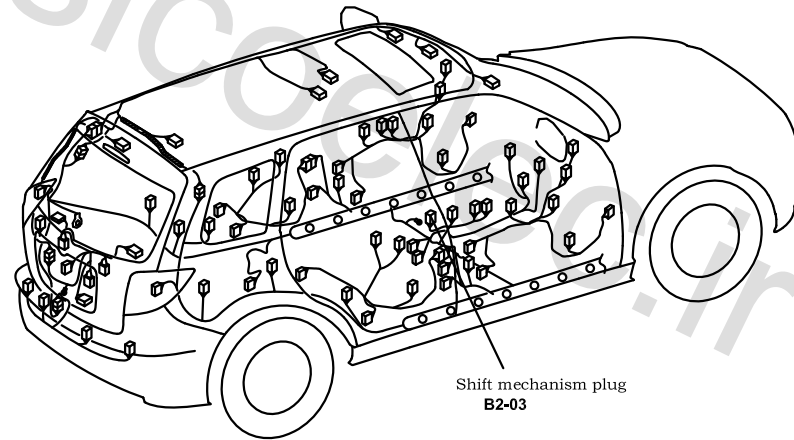
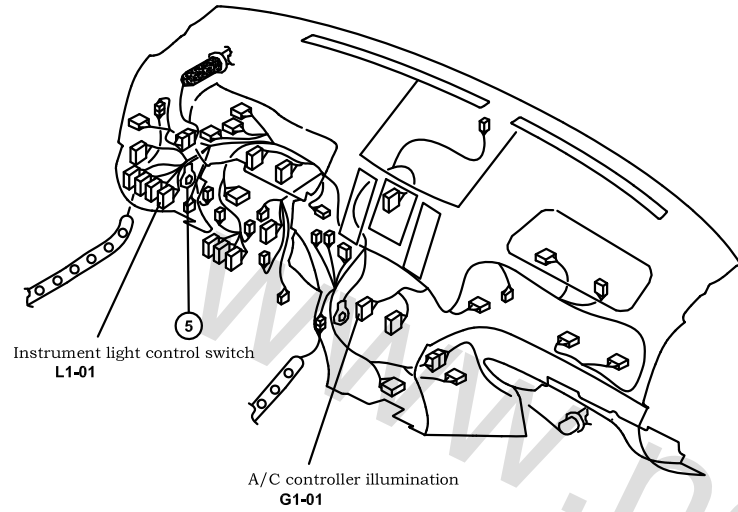
Harness mark:  (F)  (E)  (D)  (R)

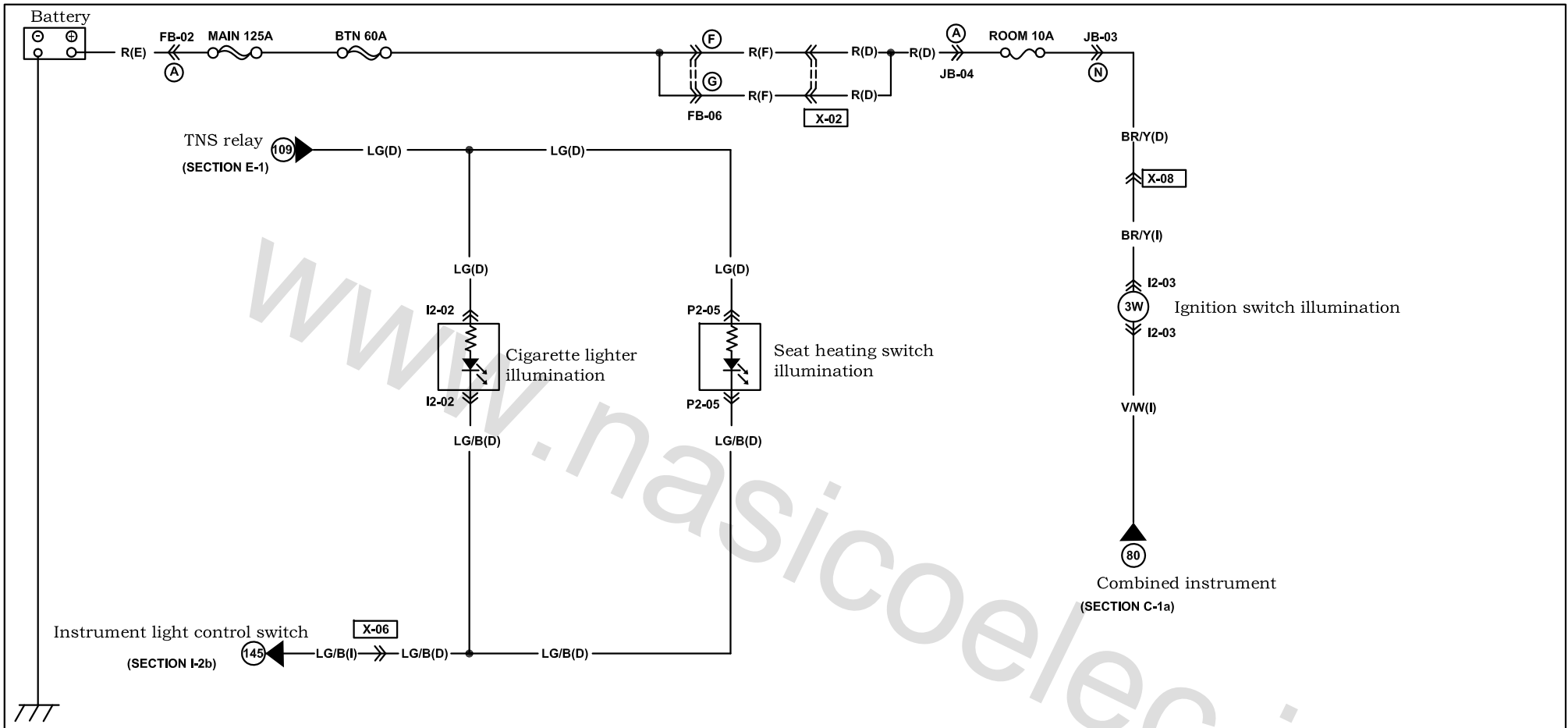

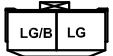

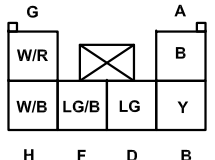
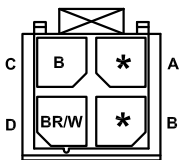
<p><b>I2-02</b> Cigarette lighter illumination(D)</p> 	<p><b>I2-03</b> Ignition switch illumination(I)</p> 	<p><b>P2-05</b> Seat heating switch (D)</p> 				
<p><b>F1-01</b> Hazard warning lamp switch illumination (I)</p> 						

Harness mark:  (F)  (E)  (D)  (R)

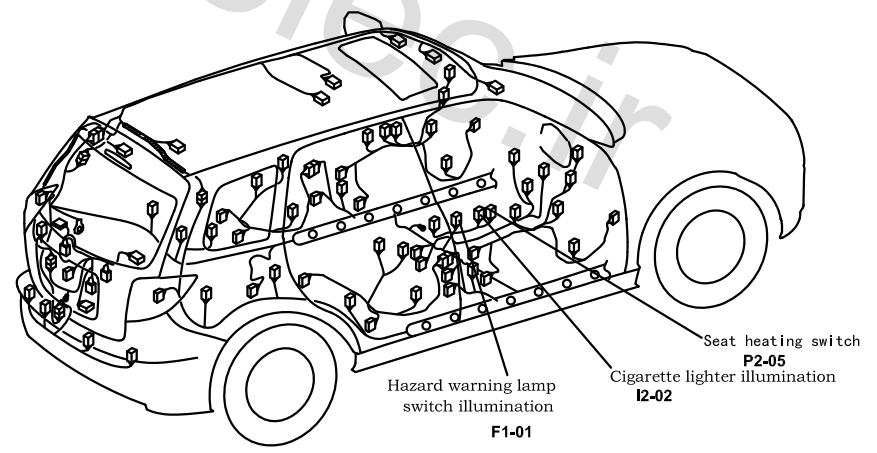
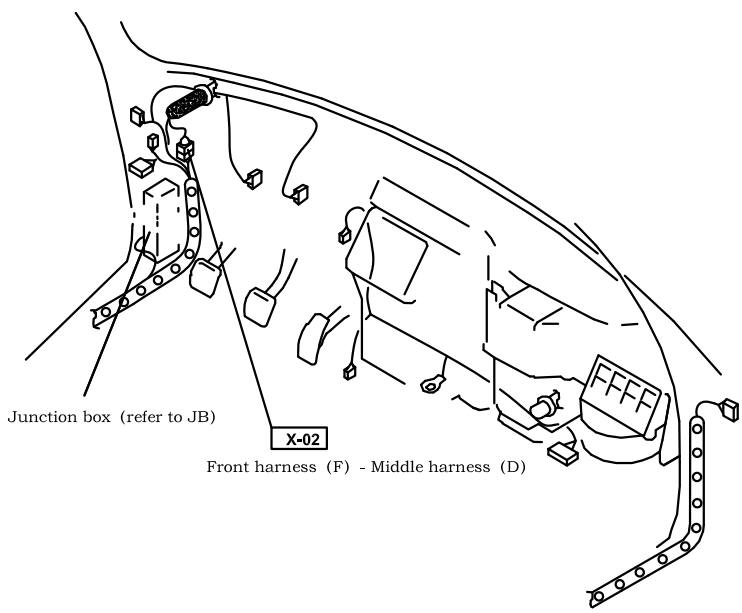
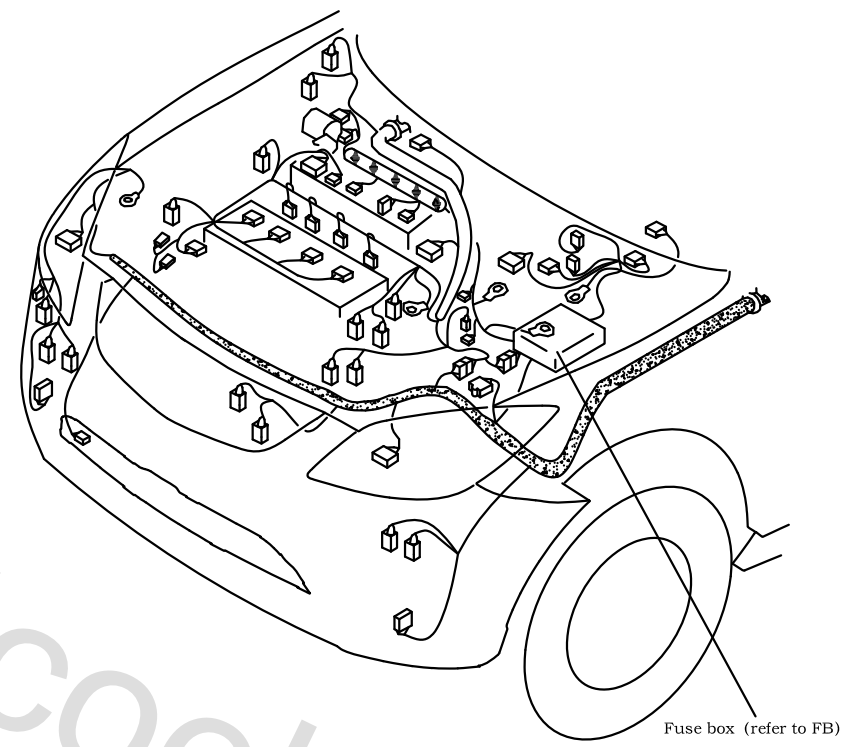
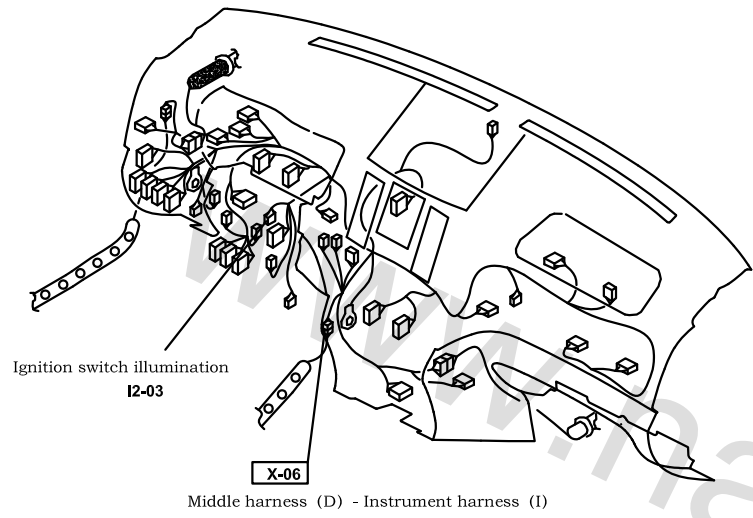

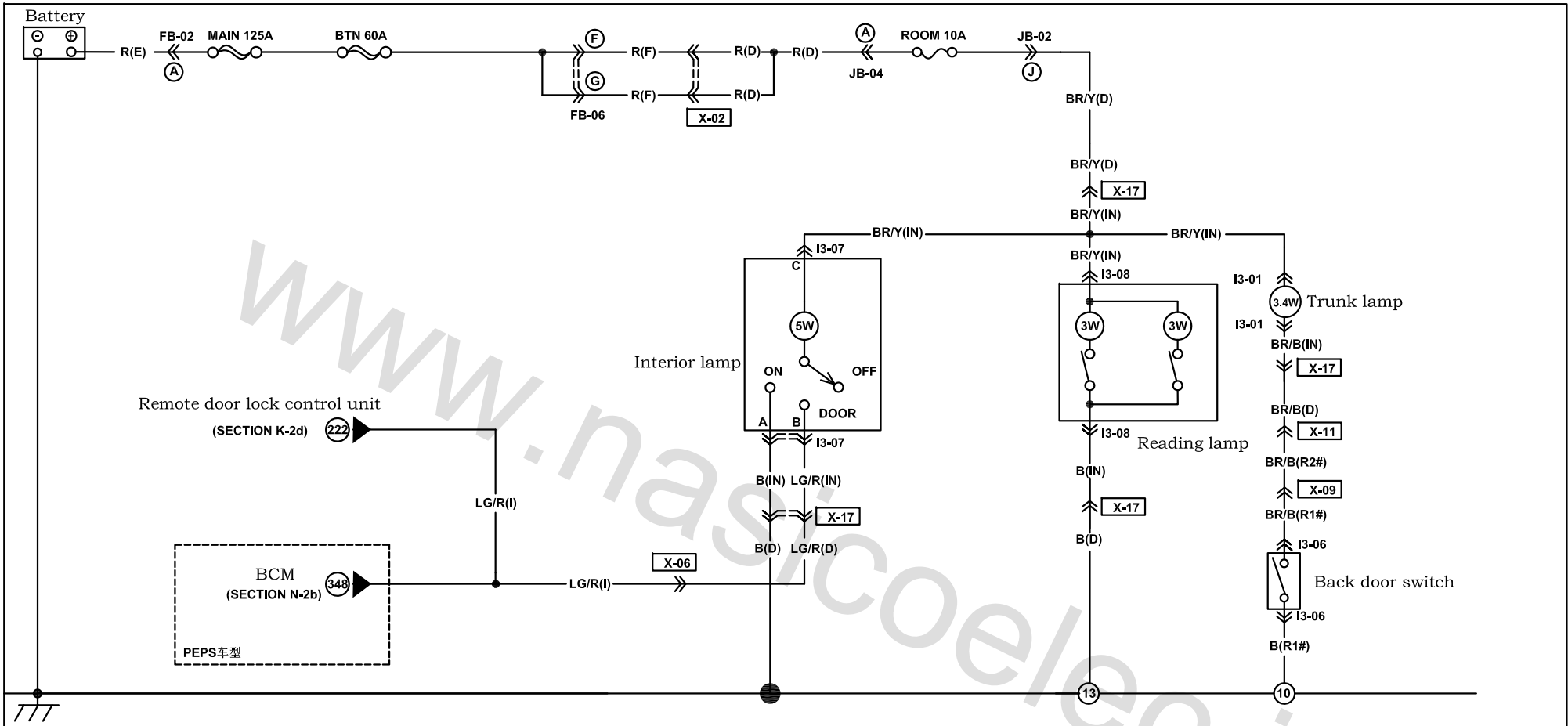

<p><b>I3-01</b> Trunk lamp (IN)</p>	<p><b>I3-06</b> Trunk lamp switch (R1#)</p>	<p><b>I3-07</b> Interior lamp (IN)</p>				
<p><b>I3-08</b> Reading lamp (IN)</p>						



Harness mark:  (F)  (E)  (D)  (R)

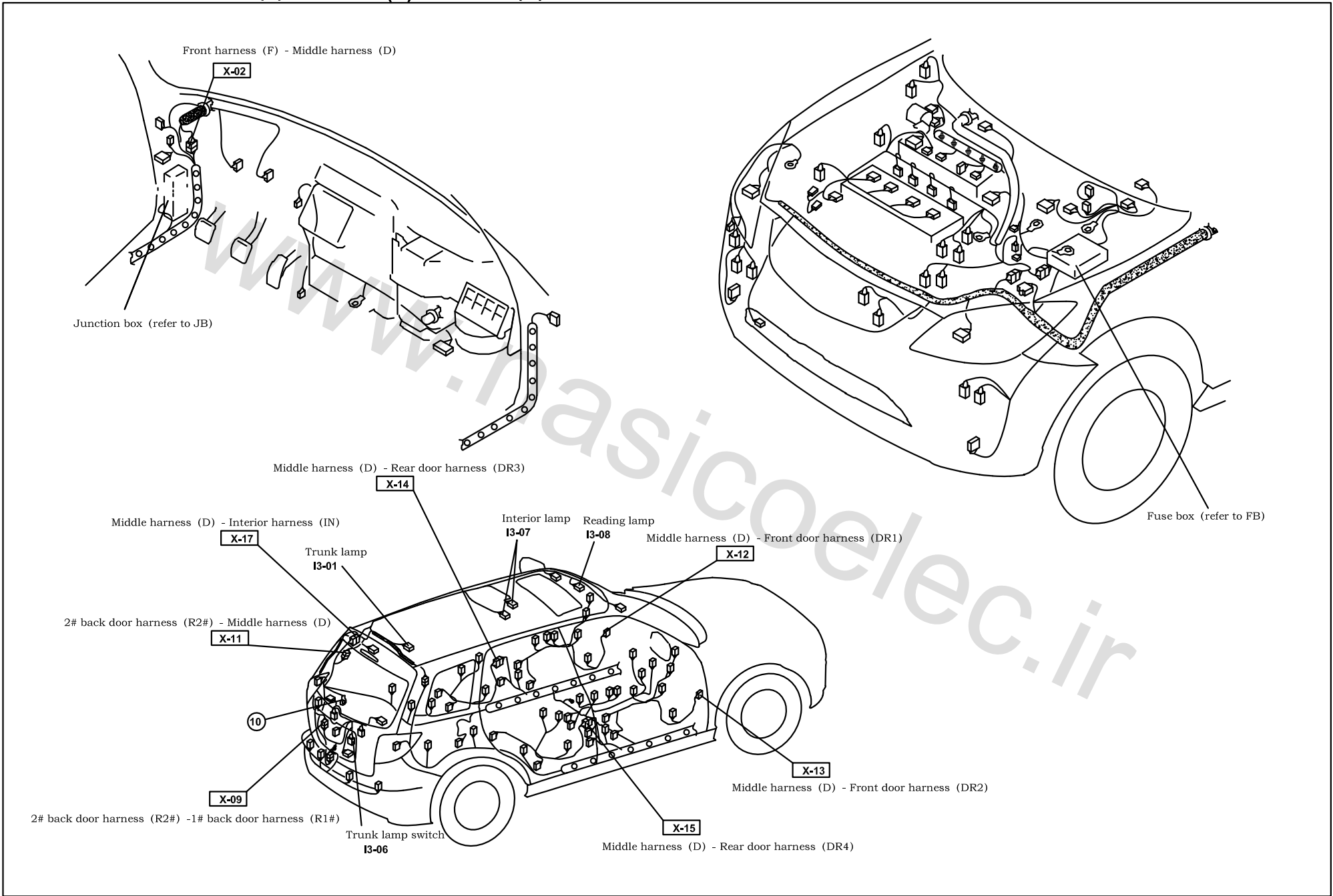

Sound system

J-1a

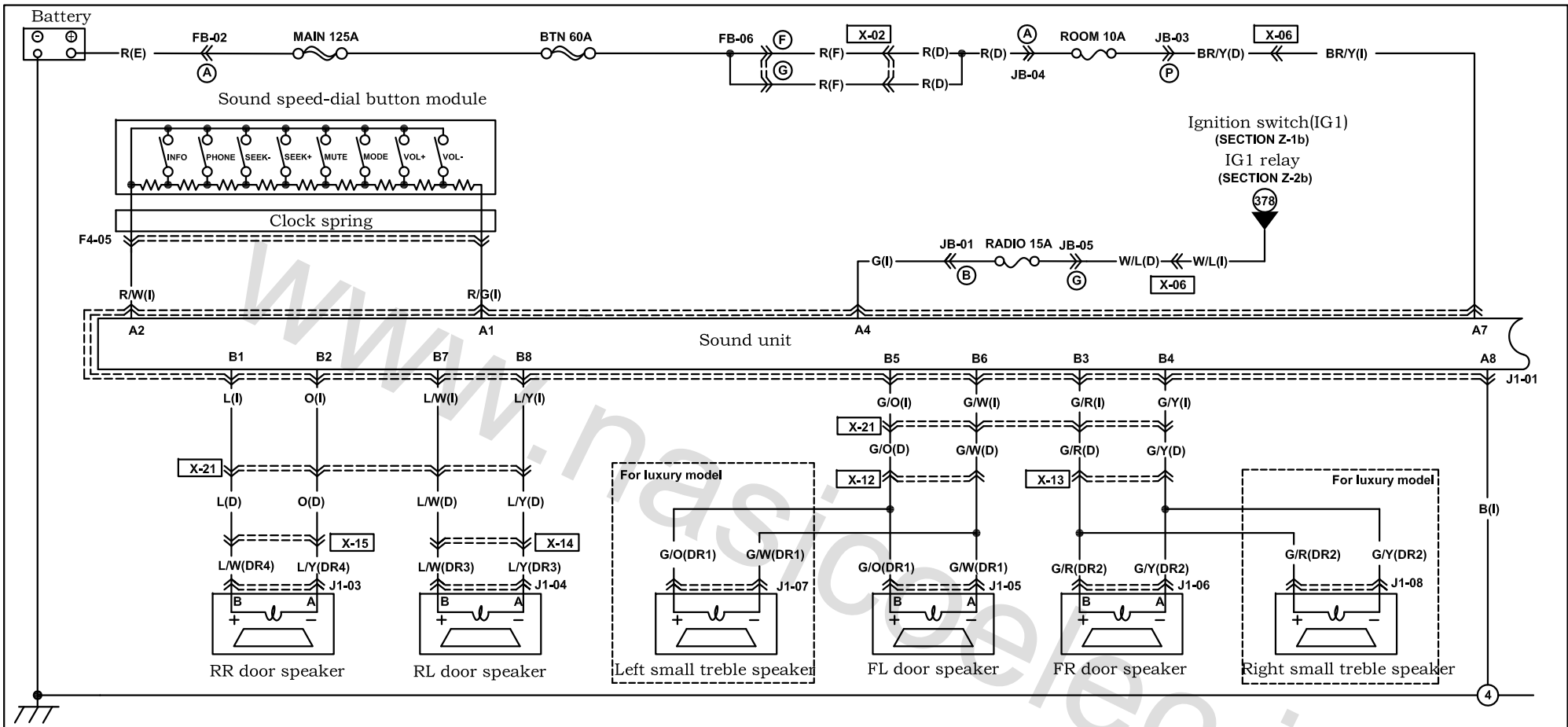

<p><b>J1-01 Sound unit (I)</b></p> <table border="1"> <tr> <th colspan="2">Yellow C1</th> <th colspan="2">Green C2</th> <th colspan="3">Blue C3</th> </tr> <tr> <td>R/B</td> <td>G</td> <td>B/G</td> <td>GR/B</td> <td>*</td> <td>*</td> <td>*</td> </tr> <tr> <td>*</td> <td>R/Y</td> <td>GR/W</td> <td>Y</td> <td>*</td> <td>*</td> <td>*</td> </tr> <tr> <td>R/L</td> <td>G/Y</td> <td>L/O</td> <td>*</td> <td>*</td> <td>*</td> <td>*</td> </tr> </table> <table border="1"> <tr> <td>A2</td> <td>R/W</td> <td>R/G</td> <td>A1</td> <td>B2</td> <td>O</td> <td>L</td> <td>B1</td> </tr> <tr> <td>Black</td> <td>G</td> <td>LG/B</td> <td>Brown</td> <td>G/Y</td> <td>G/R</td> <td></td> <td></td> </tr> <tr> <td></td> <td>LG</td> <td>*</td> <td></td> <td>G/W</td> <td>G/O</td> <td></td> <td></td> </tr> <tr> <td>A8</td> <td>B</td> <td>BR/Y</td> <td>A7</td> <td>B8</td> <td>LY</td> <td>LW</td> <td>B7</td> </tr> </table>	Yellow C1		Green C2		Blue C3			R/B	G	B/G	GR/B	*	*	*	*	R/Y	GR/W	Y	*	*	*	R/L	G/Y	L/O	*	*	*	*	A2	R/W	R/G	A1	B2	O	L	B1	Black	G	LG/B	Brown	G/Y	G/R				LG	*		G/W	G/O			A8	B	BR/Y	A7	B8	LY	LW	B7	<p><b>J1-03 RL door speaker(DR3)</b></p>	<p><b>J1-04 RR door speaker(DR4)</b></p>	<p><b>J1-05 FL door speaker(DR1)</b></p>	<p><b>J1-06 FR door speaker (DR2)</b></p>	
Yellow C1		Green C2		Blue C3																																																													
R/B	G	B/G	GR/B	*	*	*																																																											
*	R/Y	GR/W	Y	*	*	*																																																											
R/L	G/Y	L/O	*	*	*	*																																																											
A2	R/W	R/G	A1	B2	O	L	B1																																																										
Black	G	LG/B	Brown	G/Y	G/R																																																												
	LG	*		G/W	G/O																																																												
A8	B	BR/Y	A7	B8	LY	LW	B7																																																										
<p><b>F4-05 Sound speed-dial button module (I)</b> [ ] with cruise</p>																																																																	

Harness mark:  (F)  (E)  (D)  (R)

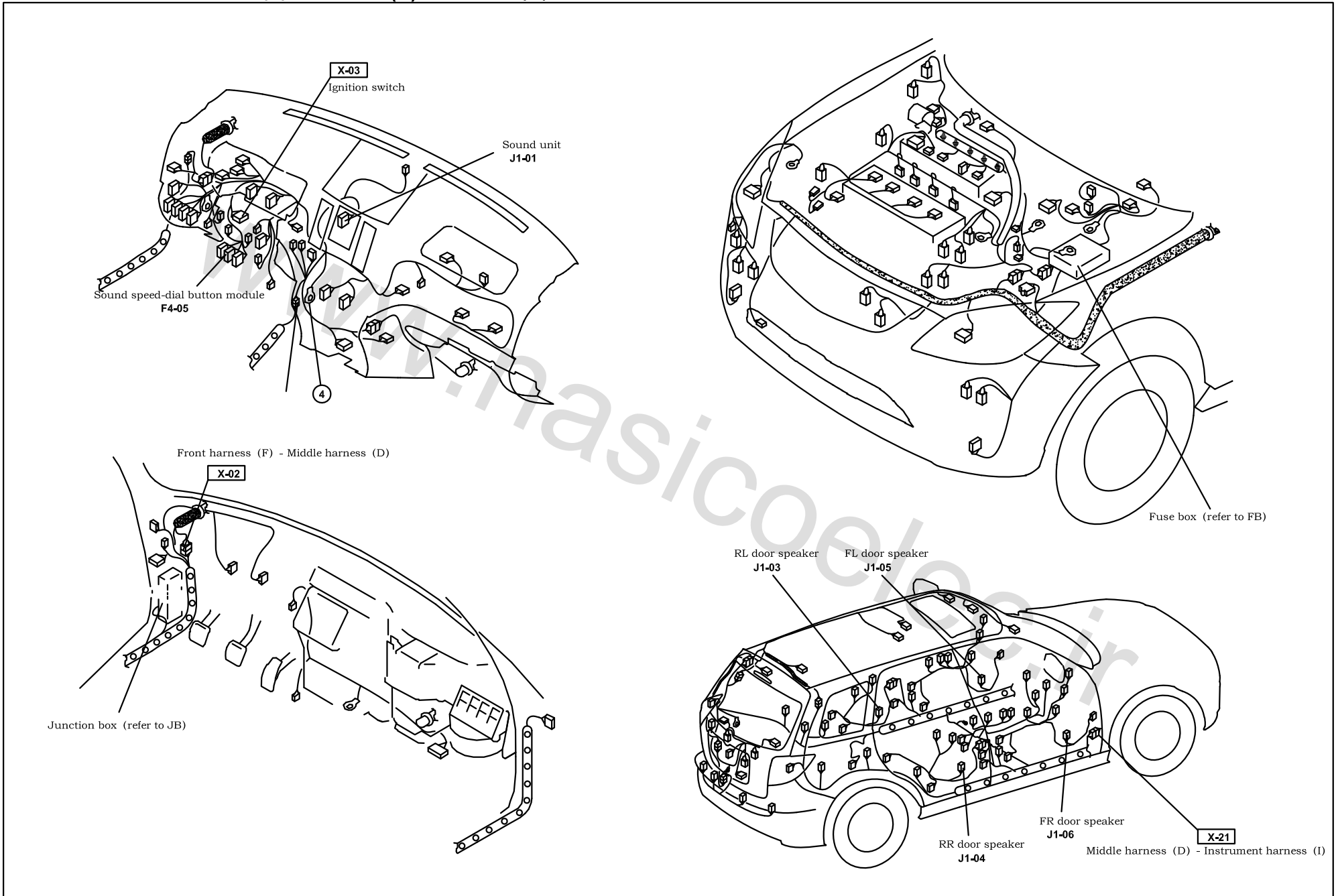

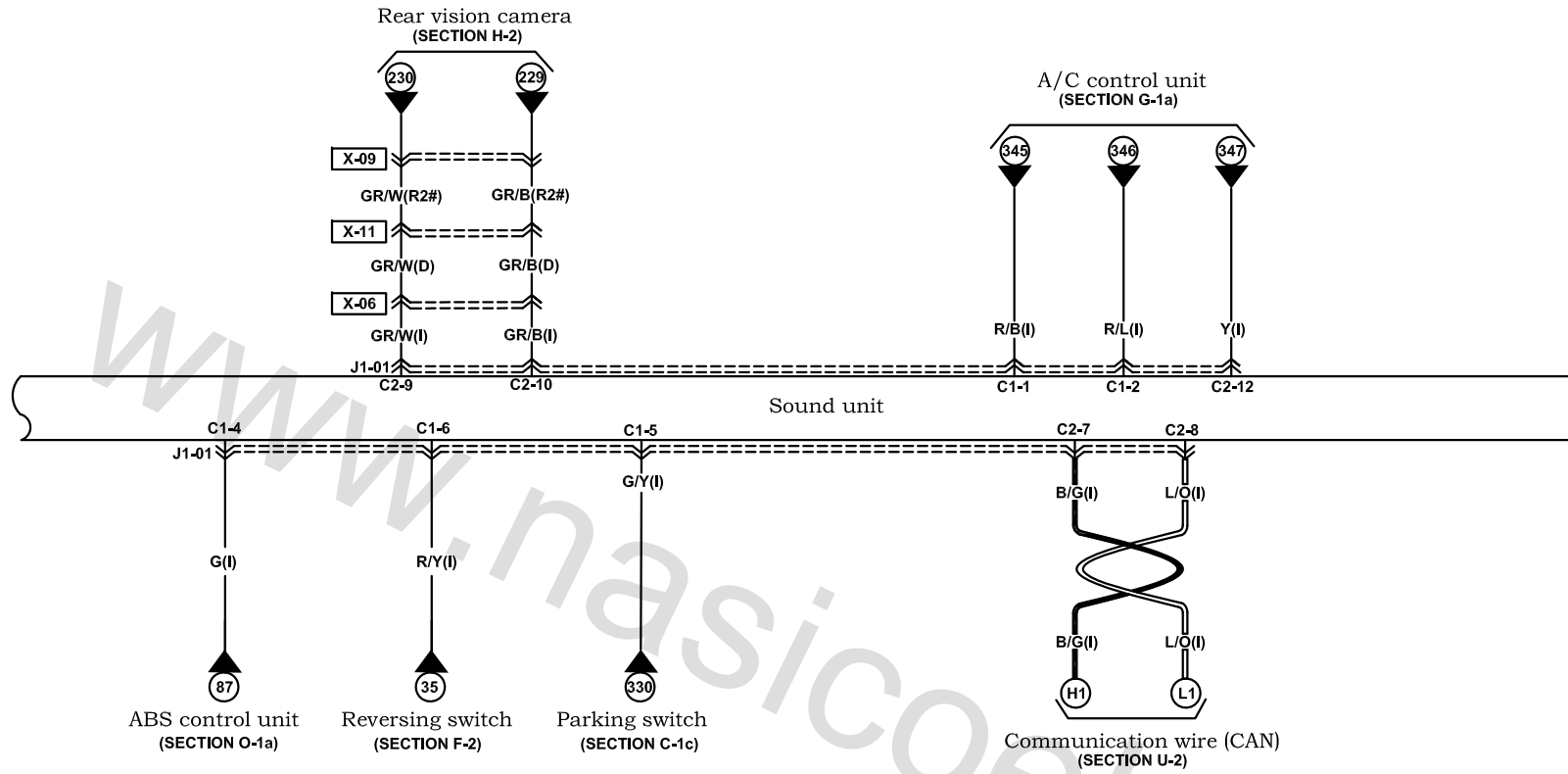

J1-01 Sound unit (I)

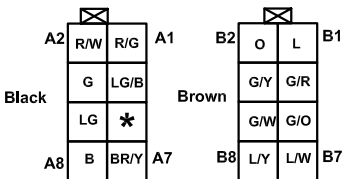
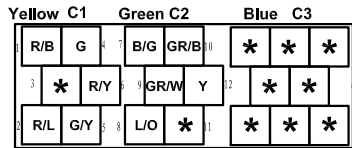

Harness mark:  (F)  (E)  (D)  (R)

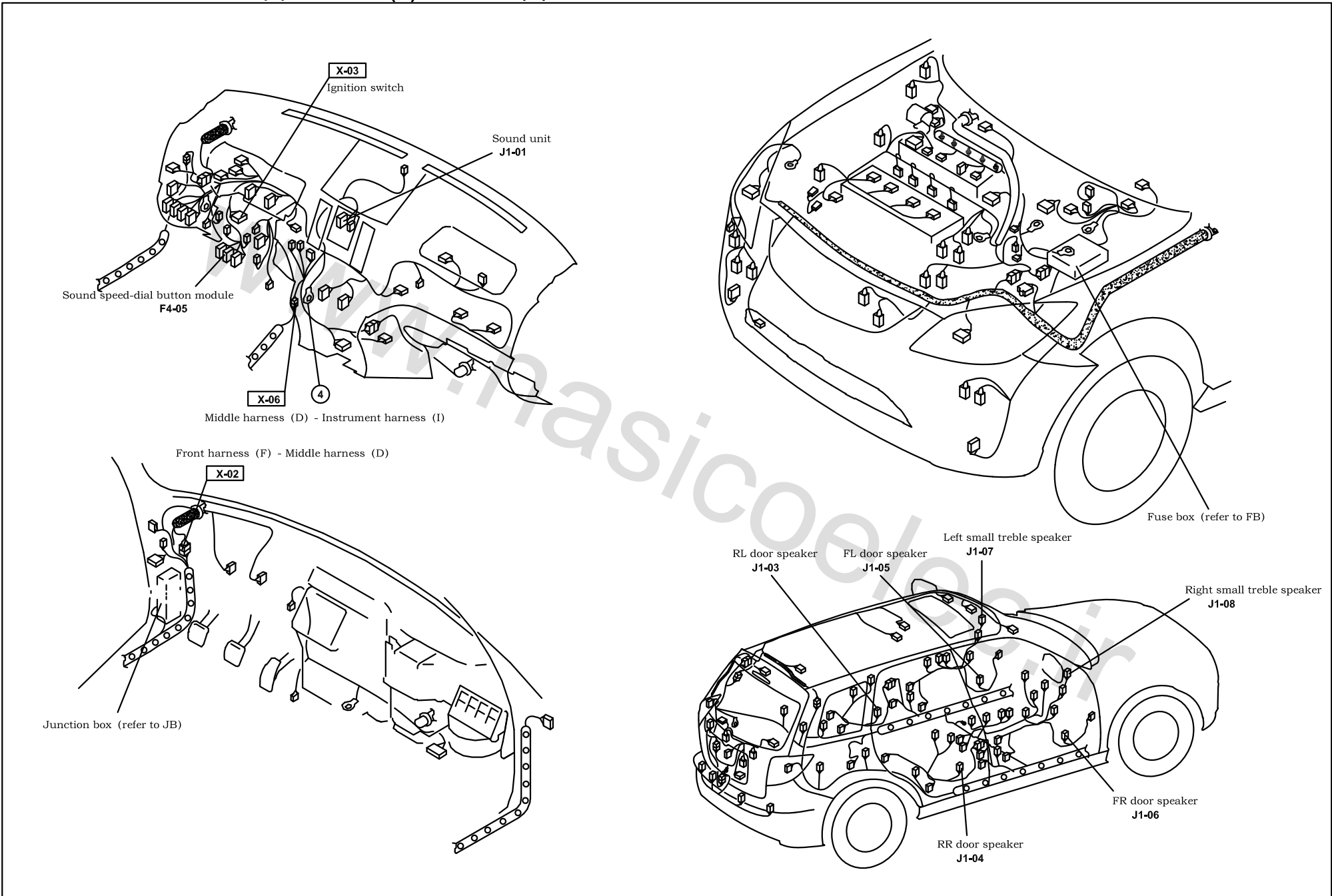

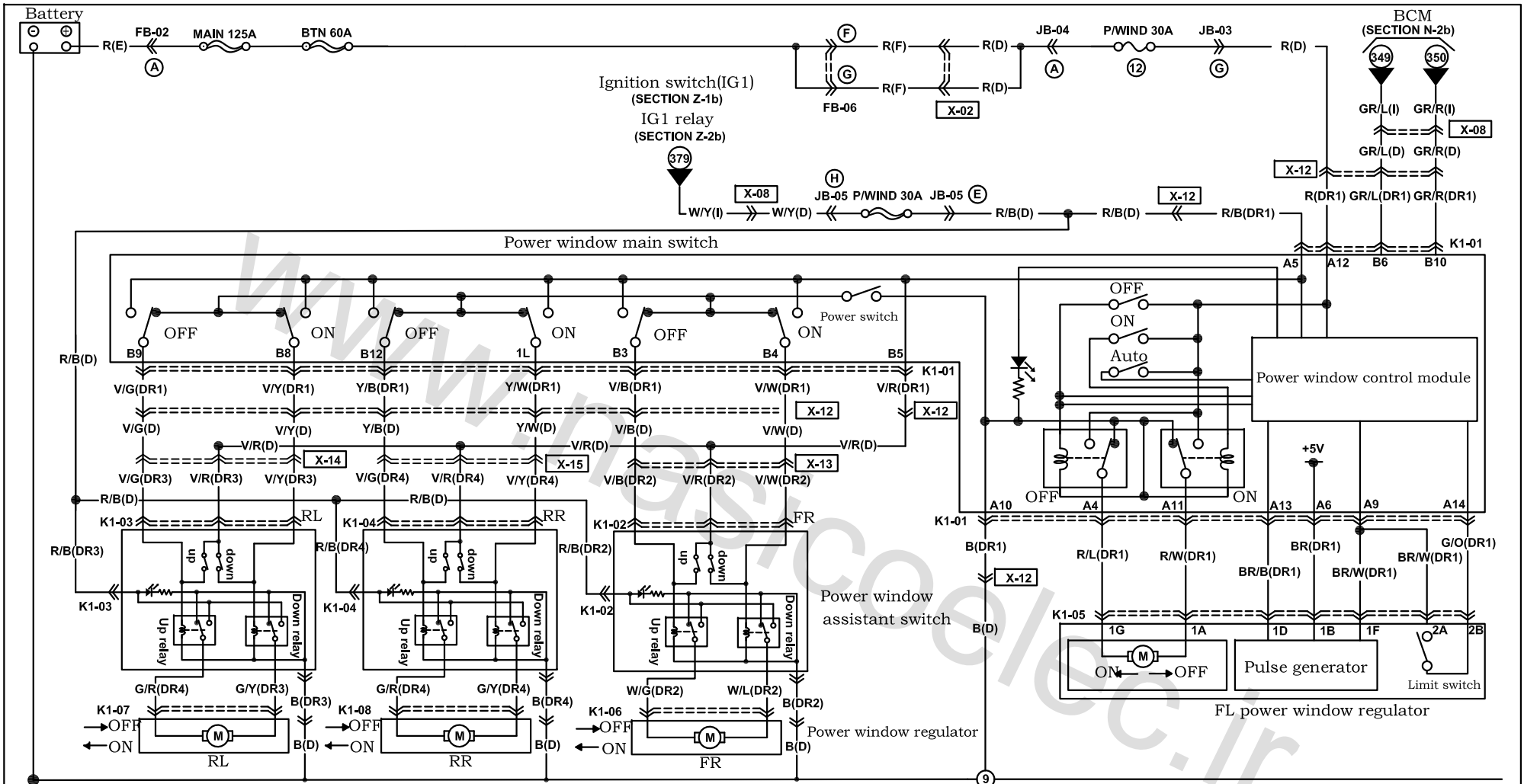

<p><b>K1-01</b> Power window main switch</p> <table border="1"> <tr> <td>A1</td><td>A2</td><td>A3</td><td>A4</td><td>A5</td><td>A6</td><td>A7</td> </tr> <tr> <td>*</td><td>*</td><td>*</td><td>R/L</td><td>R/B</td><td>BR</td><td>*</td> </tr> <tr> <td>A8</td><td>A9</td><td>A10</td><td>A11</td><td>A12</td><td>A13</td><td>A14</td> </tr> <tr> <td>*</td><td>BR/W</td><td>B</td><td>R/W</td><td>R</td><td>BR/B</td><td>G/O</td> </tr> </table>	A1	A2	A3	A4	A5	A6	A7	*	*	*	R/L	R/B	BR	*	A8	A9	A10	A11	A12	A13	A14	*	BR/W	B	R/W	R	BR/B	G/O	<table border="1"> <tr> <td>B1</td><td>B2</td><td>B3</td><td>B4</td><td>B5</td><td>B6</td> </tr> <tr> <td>*</td><td>*</td><td>V/B</td><td>V/W</td><td>V/R</td><td>GR/L</td> </tr> <tr> <td>B7</td><td>B8</td><td>B9</td><td>B10</td><td>B11</td><td>B12</td> </tr> <tr> <td>*</td><td>V/Y</td><td>V/G</td><td>GR/R</td><td>Y/W</td><td>Y/B</td> </tr> </table>	B1	B2	B3	B4	B5	B6	*	*	V/B	V/W	V/R	GR/L	B7	B8	B9	B10	B11	B12	*	V/Y	V/G	GR/R	Y/W	Y/B	<p><b>K1-02</b> FR power window assistant switch (DR2)</p> <table border="1"> <tr> <td>C1</td><td>C2</td><td>C3</td><td>C4</td><td>C5</td><td>C6</td> </tr> <tr> <td>V/W</td><td>*</td><td>W/G</td><td>V/R</td><td>B</td><td>*</td> </tr> <tr> <td>C7</td><td>C8</td><td>C9</td><td>C10</td><td>C11</td><td>C12</td> </tr> <tr> <td>V/B</td><td>R/B</td><td>W/L</td><td>*</td><td>*</td><td>*</td> </tr> </table>	C1	C2	C3	C4	C5	C6	V/W	*	W/G	V/R	B	*	C7	C8	C9	C10	C11	C12	V/B	R/B	W/L	*	*	*	<p><b>K1-03</b> RL power window assistant switch (DR3)</p> <table border="1"> <tr> <td>C1</td><td>C2</td><td>C3</td><td>C4</td><td>C5</td><td>C6</td> </tr> <tr> <td>V/Y</td><td>*</td><td>G/R</td><td>V/R</td><td>B</td><td>*</td> </tr> <tr> <td>C7</td><td>C8</td><td>C9</td><td>C10</td><td>C11</td><td>C12</td> </tr> <tr> <td>V/G</td><td>R/B</td><td>G/Y</td><td>*</td><td>*</td><td>*</td> </tr> </table>	C1	C2	C3	C4	C5	C6	V/Y	*	G/R	V/R	B	*	C7	C8	C9	C10	C11	C12	V/G	R/B	G/Y	*	*	*
A1	A2	A3	A4	A5	A6	A7																																																																																																	
*	*	*	R/L	R/B	BR	*																																																																																																	
A8	A9	A10	A11	A12	A13	A14																																																																																																	
*	BR/W	B	R/W	R	BR/B	G/O																																																																																																	
B1	B2	B3	B4	B5	B6																																																																																																		
*	*	V/B	V/W	V/R	GR/L																																																																																																		
B7	B8	B9	B10	B11	B12																																																																																																		
*	V/Y	V/G	GR/R	Y/W	Y/B																																																																																																		
C1	C2	C3	C4	C5	C6																																																																																																		
V/W	*	W/G	V/R	B	*																																																																																																		
C7	C8	C9	C10	C11	C12																																																																																																		
V/B	R/B	W/L	*	*	*																																																																																																		
C1	C2	C3	C4	C5	C6																																																																																																		
V/Y	*	G/R	V/R	B	*																																																																																																		
C7	C8	C9	C10	C11	C12																																																																																																		
V/G	R/B	G/Y	*	*	*																																																																																																		
<p><b>K1-06</b> FR power window regulator (DR2)</p> <table border="1"> <tr> <td>W/G</td> </tr> <tr> <td>W/L</td> </tr> </table>	W/G	W/L	<p><b>K1-07</b> RL power window regulator (DR3)</p> <table border="1"> <tr> <td>G/Y</td> </tr> <tr> <td>G/R</td> </tr> </table>	G/Y	G/R	<p><b>K1-08</b> RR power window regulator (DR4)</p> <table border="1"> <tr> <td>G/Y</td> </tr> <tr> <td>G/R</td> </tr> </table>	G/Y	G/R	<p><b>K1-04</b> RR power window assistant switch (DR4)</p> <table border="1"> <tr> <td>C1</td><td>C2</td><td>C3</td><td>C4</td><td>C5</td><td>C6</td> </tr> <tr> <td>V/Y</td><td>*</td><td>G/R</td><td>V/R</td><td>B</td><td>*</td> </tr> <tr> <td>C7</td><td>C8</td><td>C9</td><td>C10</td><td>C11</td><td>C12</td> </tr> <tr> <td>V/G</td><td>R/B</td><td>G/Y</td><td>*</td><td>*</td><td>*</td> </tr> </table>	C1	C2	C3	C4	C5	C6	V/Y	*	G/R	V/R	B	*	C7	C8	C9	C10	C11	C12	V/G	R/B	G/Y	*	*	*	<p><b>K1-05</b> FL power window regulator (DR1)</p> <table border="1"> <tr> <td>1A</td><td>1B</td><td>1C</td><td>1D</td><td>1E</td><td>1F</td> </tr> <tr> <td>R/W</td><td>R/L</td><td>BR</td><td>BR/B</td><td>BR/W</td><td>*</td> </tr> </table>	1A	1B	1C	1D	1E	1F	R/W	R/L	BR	BR/B	BR/W	*																																																									
W/G																																																																																																							
W/L																																																																																																							
G/Y																																																																																																							
G/R																																																																																																							
G/Y																																																																																																							
G/R																																																																																																							
C1	C2	C3	C4	C5	C6																																																																																																		
V/Y	*	G/R	V/R	B	*																																																																																																		
C7	C8	C9	C10	C11	C12																																																																																																		
V/G	R/B	G/Y	*	*	*																																																																																																		
1A	1B	1C	1D	1E	1F																																																																																																		
R/W	R/L	BR	BR/B	BR/W	*																																																																																																		

Harness mark:  (F)  (E)  (D)  (R)

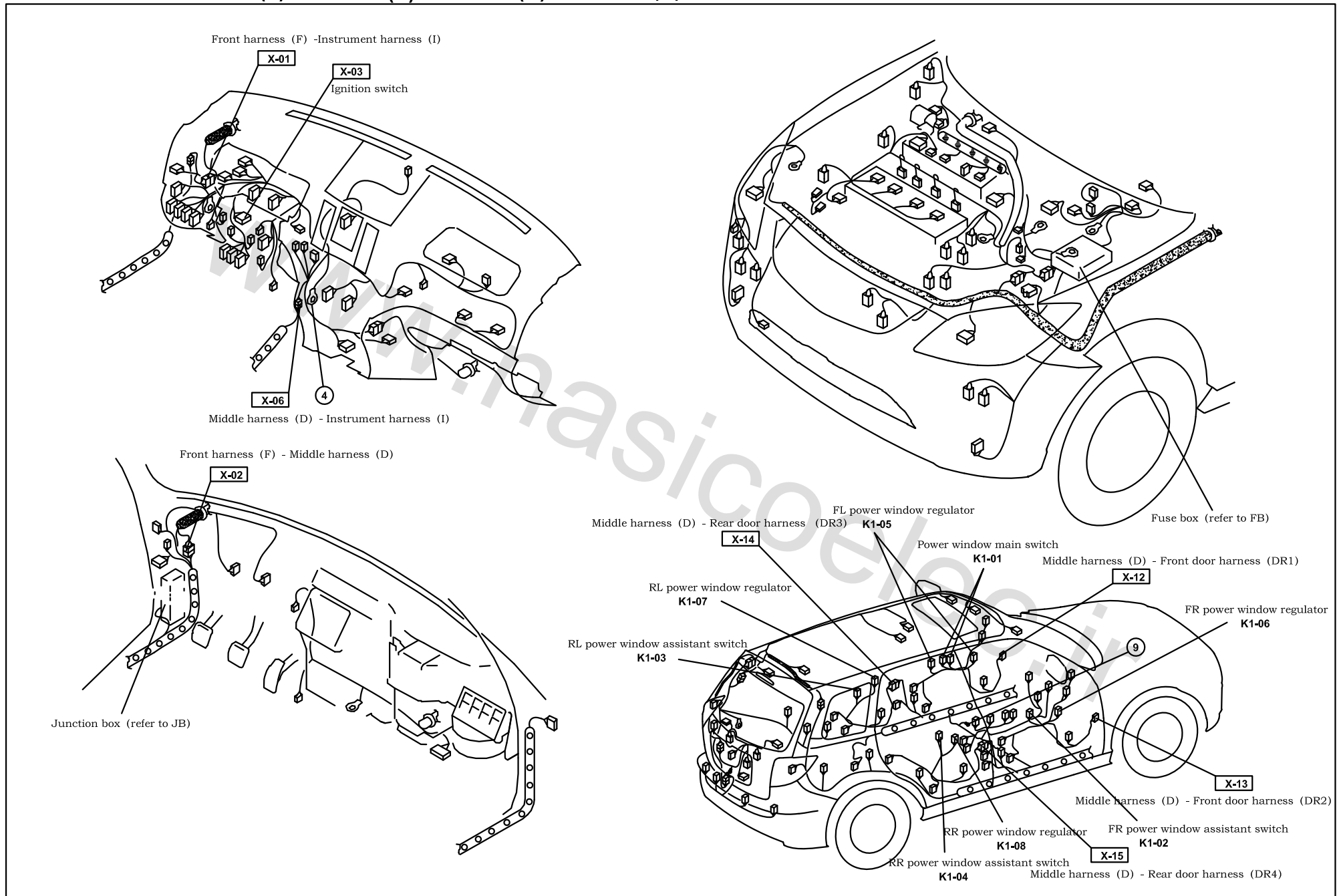

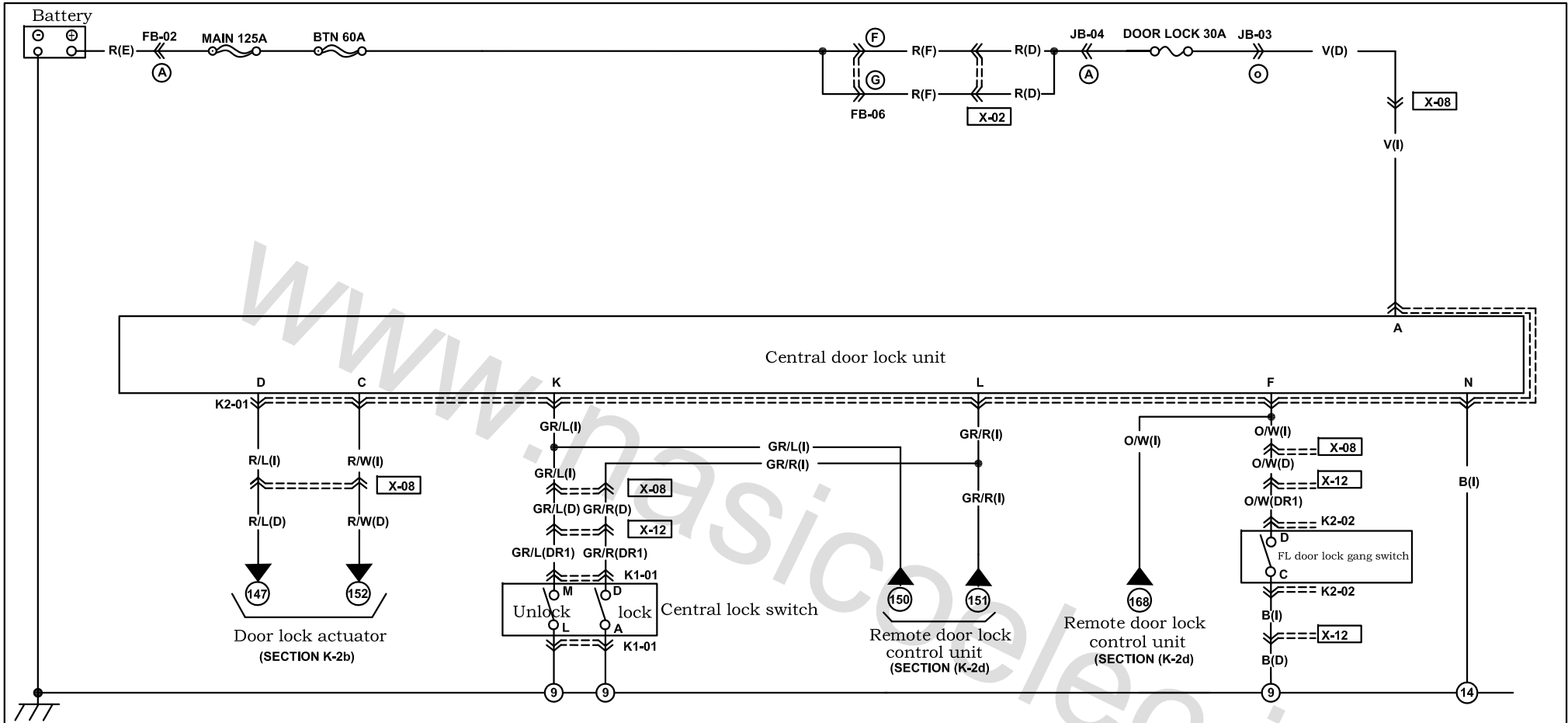

# Remote and central door lock system

K-2a



<p><b>K2-01</b> Central door lock unit (D)</p>	<p><b>K1-01</b> Power window main switch (DR1)</p>	<p><b>K2-02</b> FL door lock actuator (DR1)</p>	

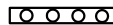
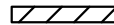

Harness mark:  (F)  (E)  (D)  (R)

Middle harness (D) - Instrument harness (I)

X-08

Central door lock unit  
K2-01

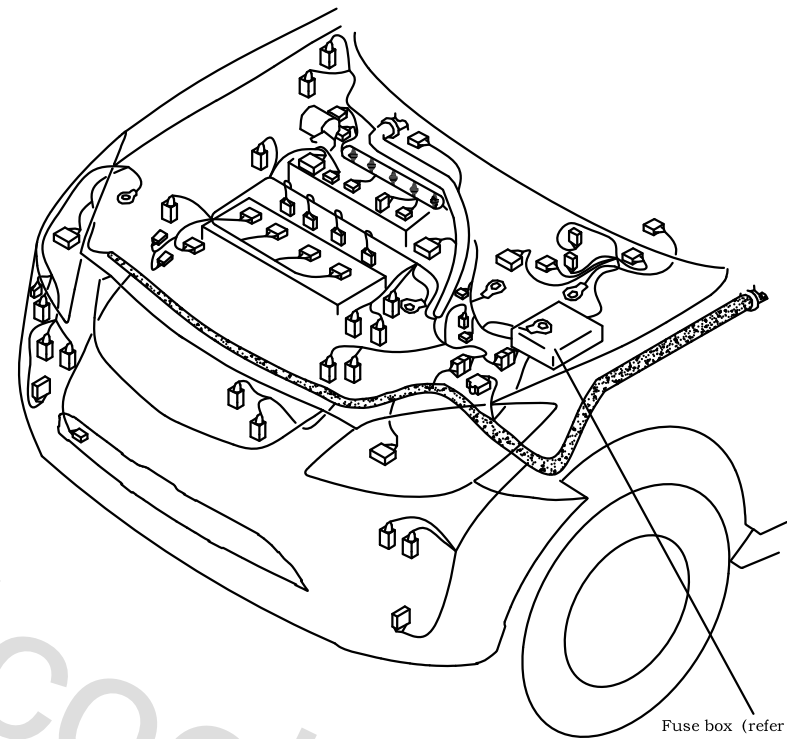
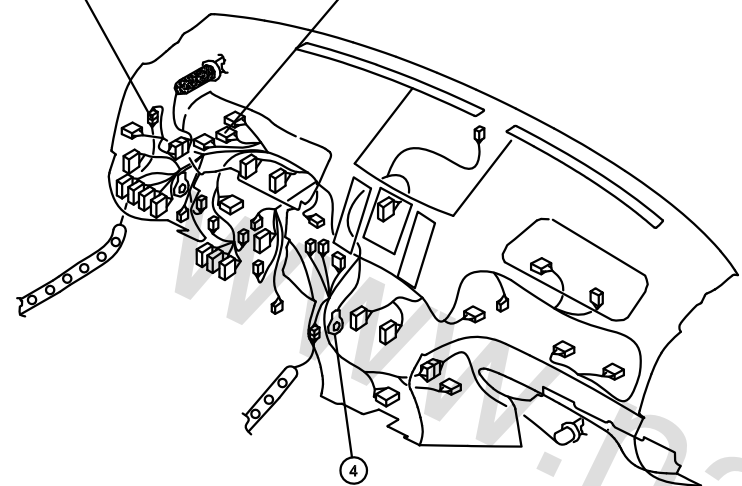

Fuse box (refer to FB)

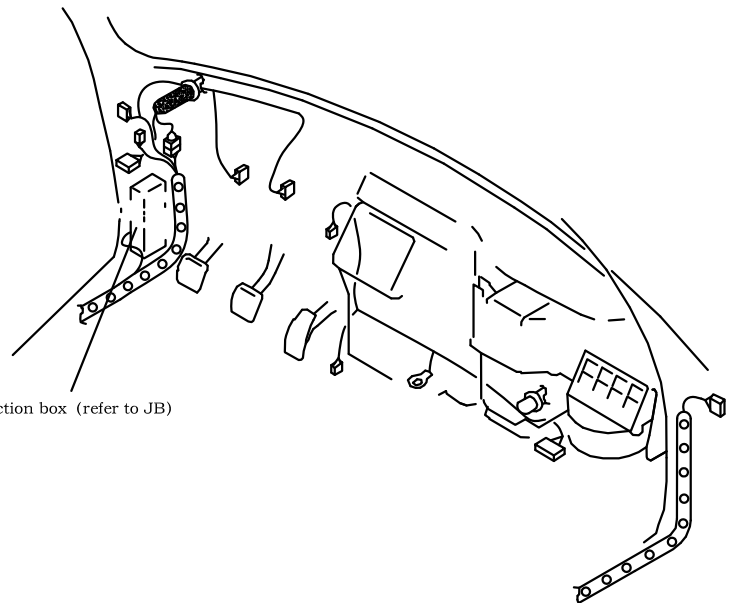

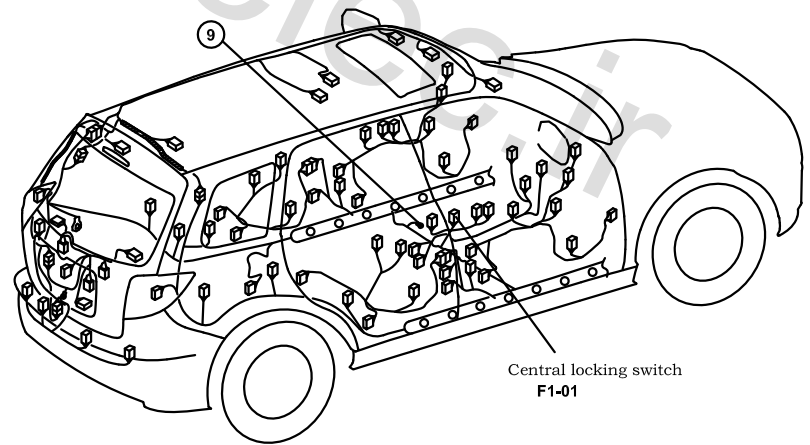

Junction box (refer to JB)

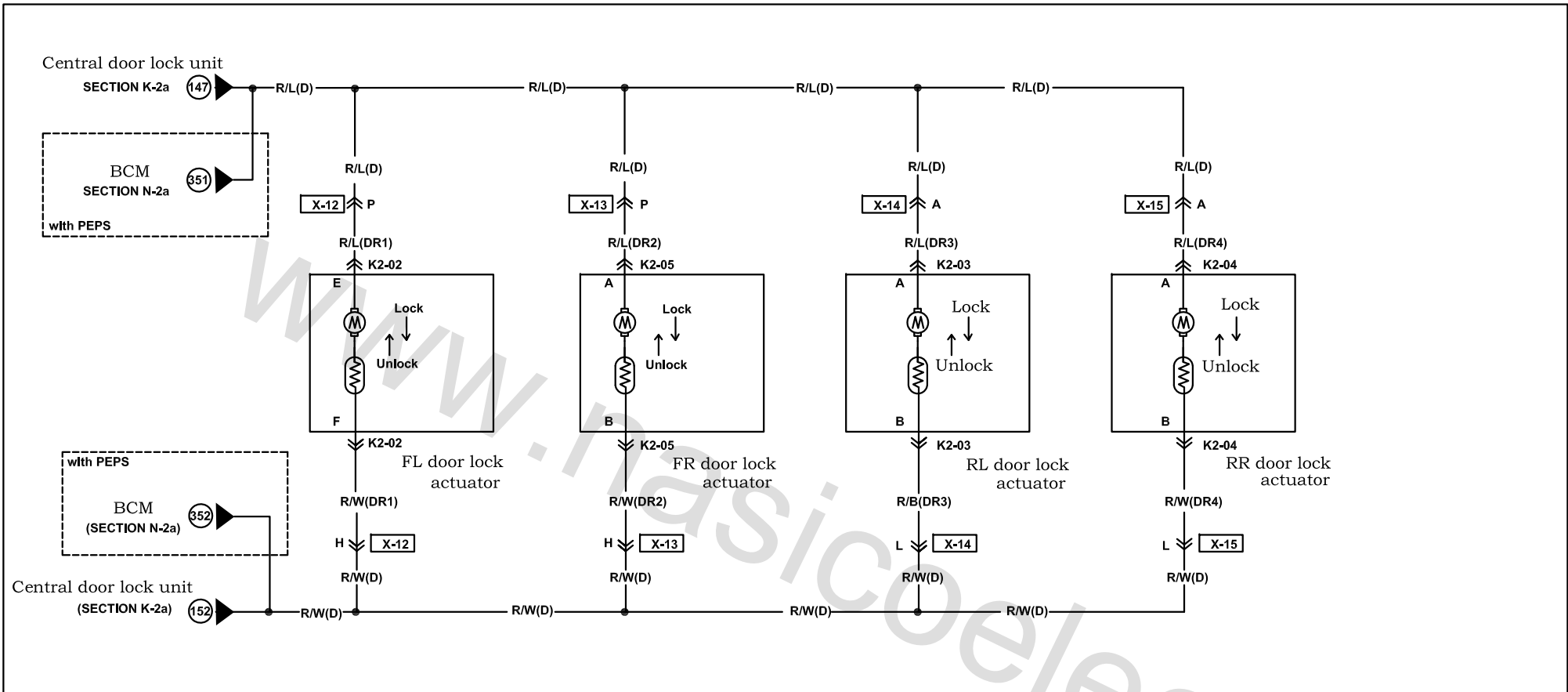

Central locking switch  
F1-01

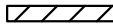

<p><b>K2-02</b> FL door lock actuator (DR1)</p>	<p><b>K2-04</b> RR door lock actuator (DR4)</p>			
<p><b>K2-03</b> RL door lock actuator (DR3)</p>	<p><b>K2-05</b> FR door lock actuator (DR2) <span style="float: right;">\$ with PEPS</span></p>			

Harness mark:  (F)  (E)  (D)  (R)

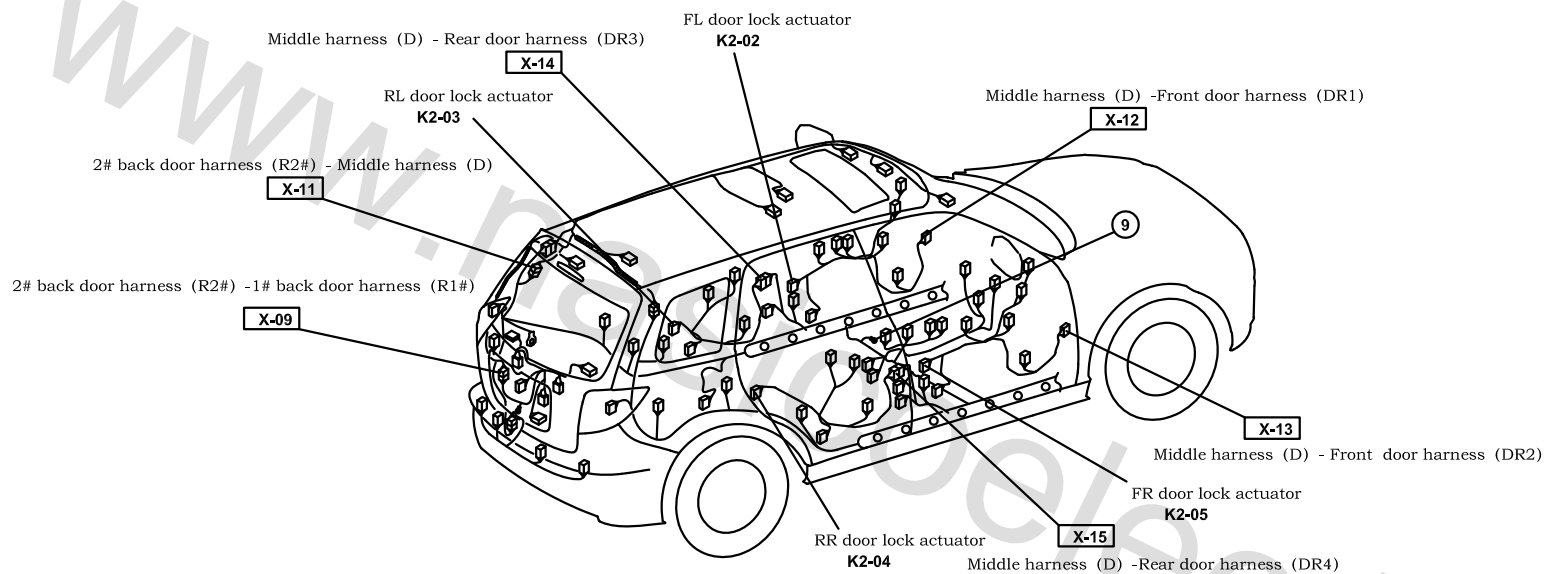



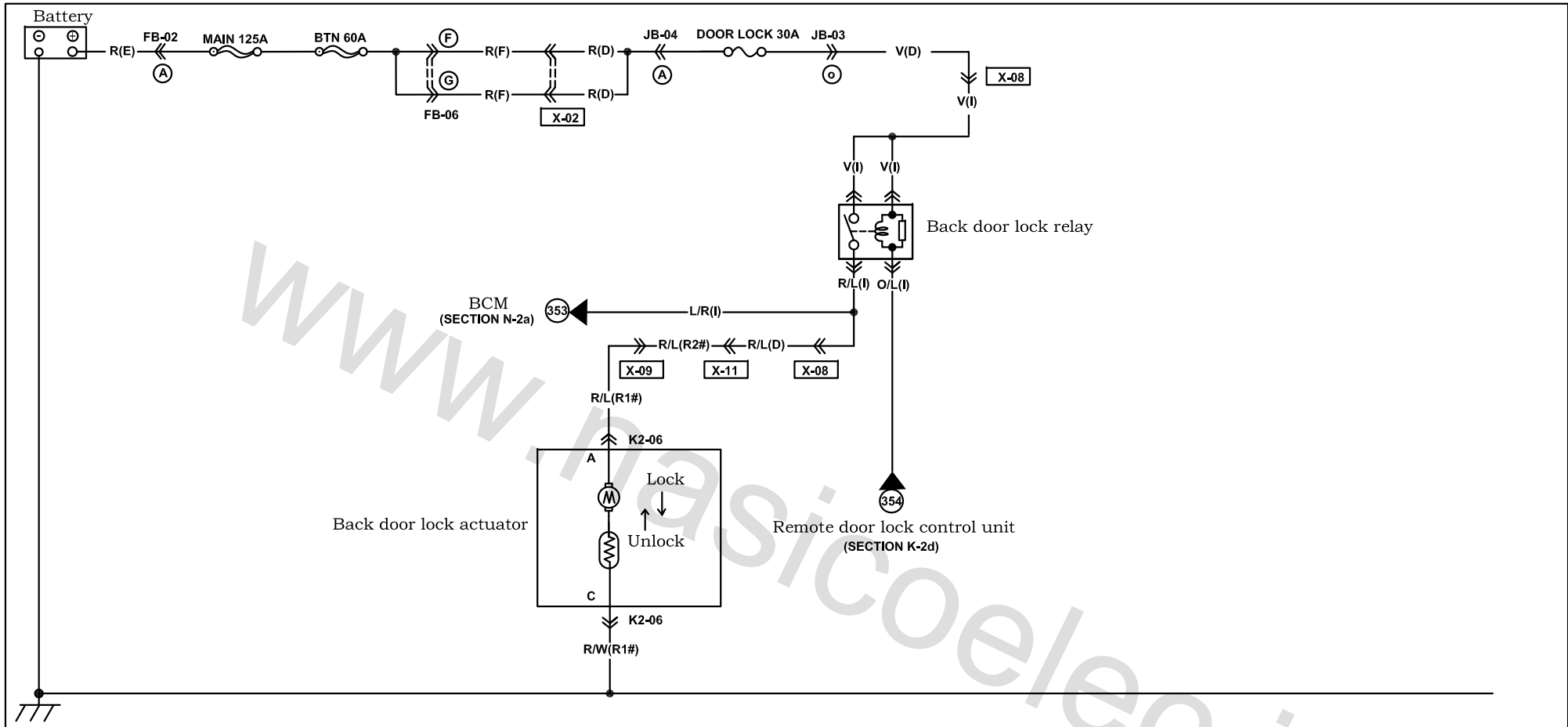

# Remote and central door lock system

K-2c



K2-06 Back door open motor (R1 #)

E	D	C	B	A
*	*	L/R	*	B

Harness mark:  (F)  (E)  (D)  (R)

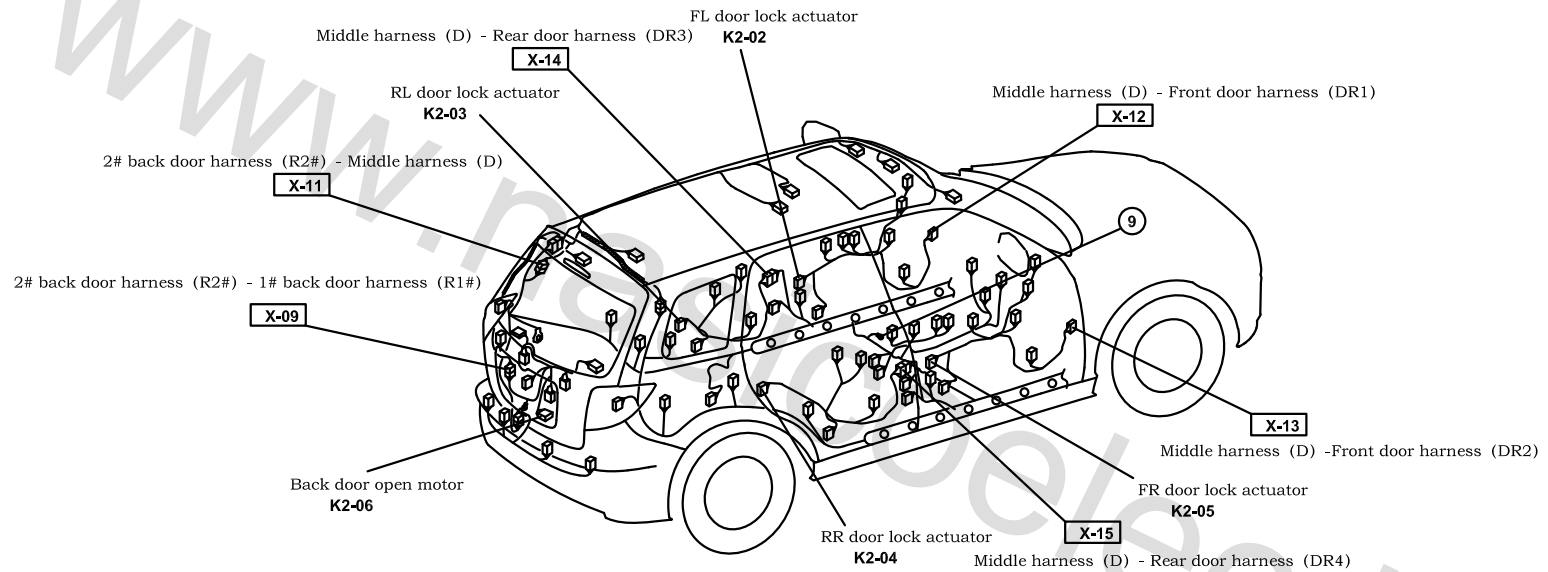

# Remote and central door lock system

K-2d

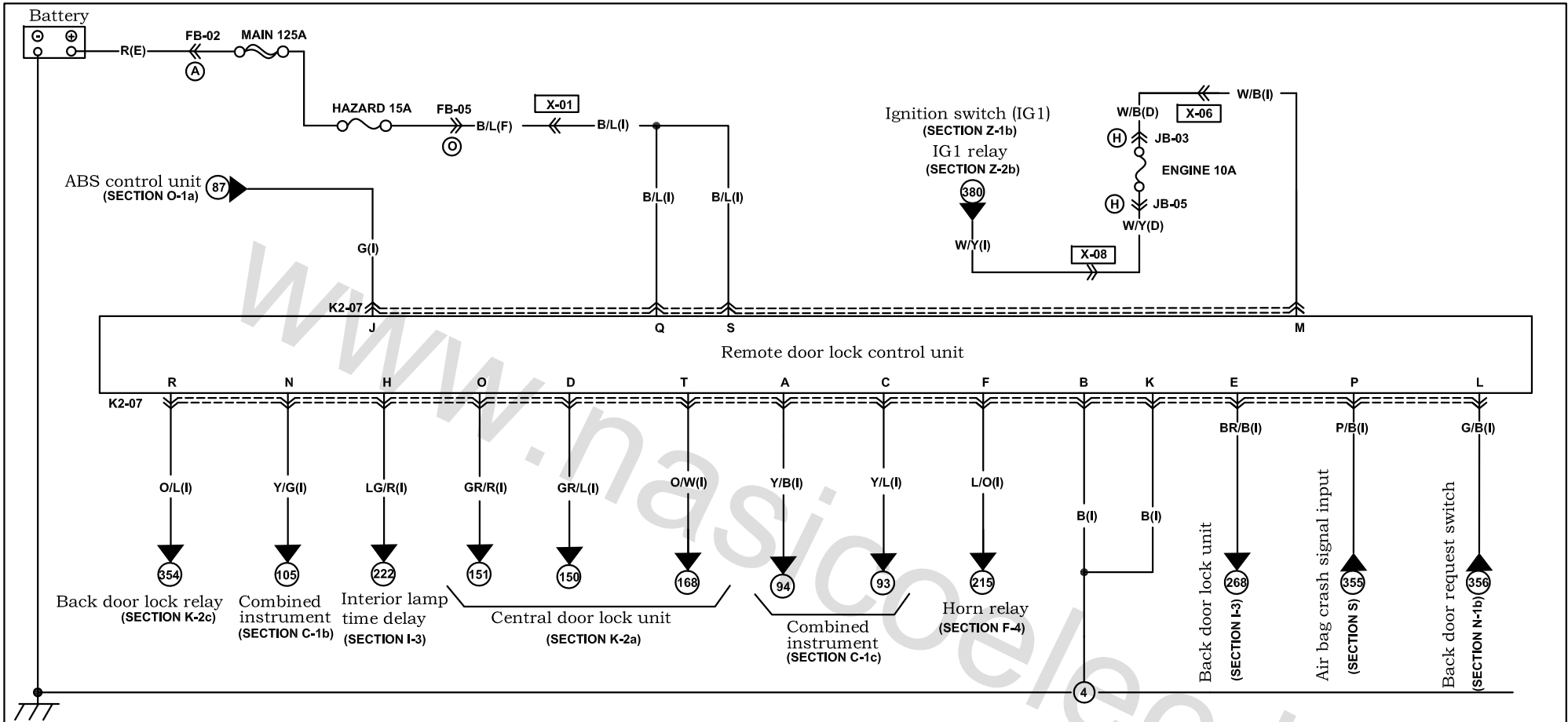

K2-07 Remote door lock control unit (I)

S	Q	O	M	<del>K</del>	I	G	E	C	A
B/L	B/L	GR/R	W/B	B	*	*	BR/B	Y/L	Y/B
O/W	O/L	P/B	Y/G	G/B	G	LG/R	L/O	GR/L	B
T	R	P	N	L	J	H	F	D	B

Harness mark:  (F)  (E)  (D)  (R)

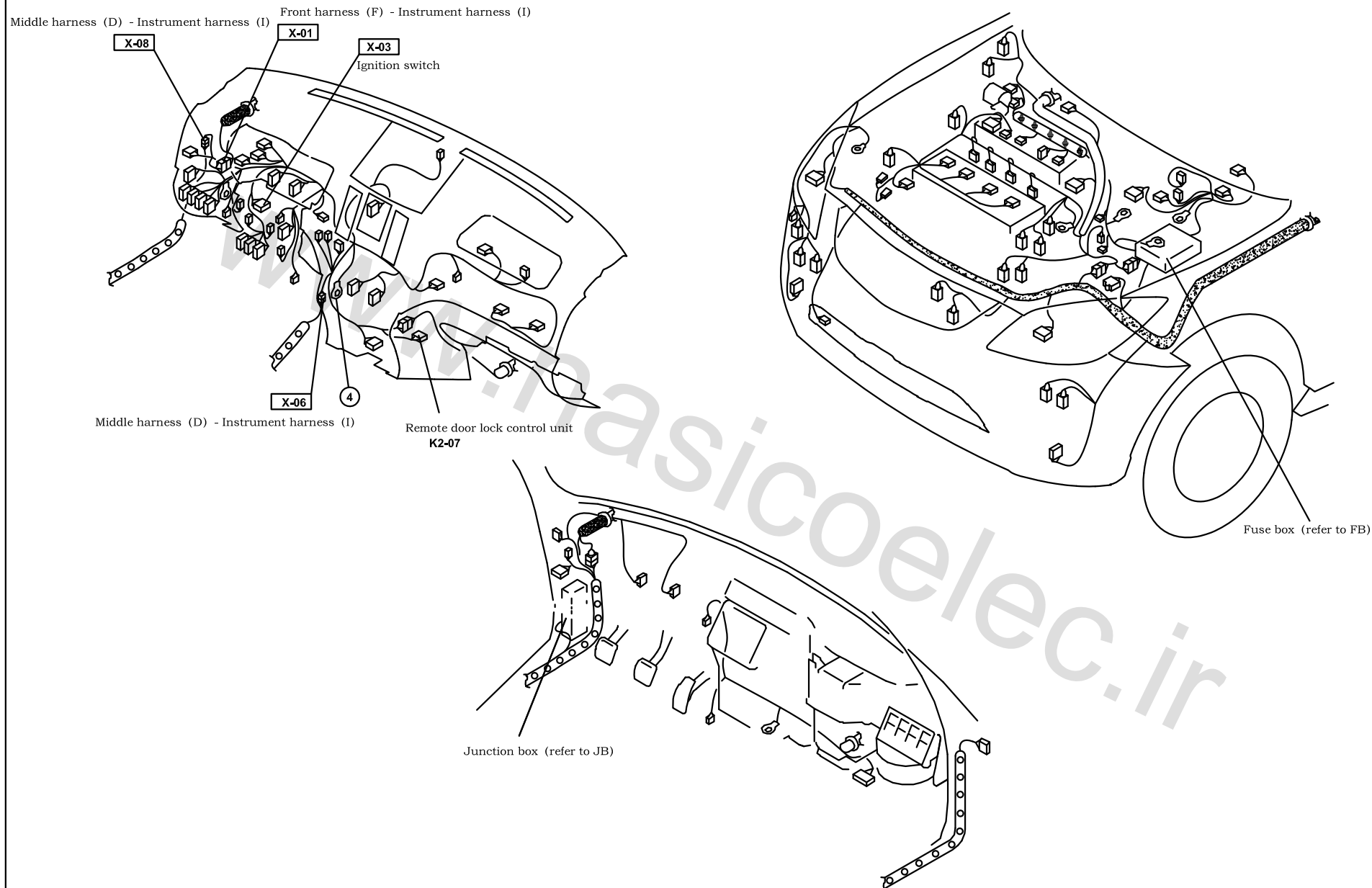

# Exterior rearview mirror heater/power exterior rearview mirror

L

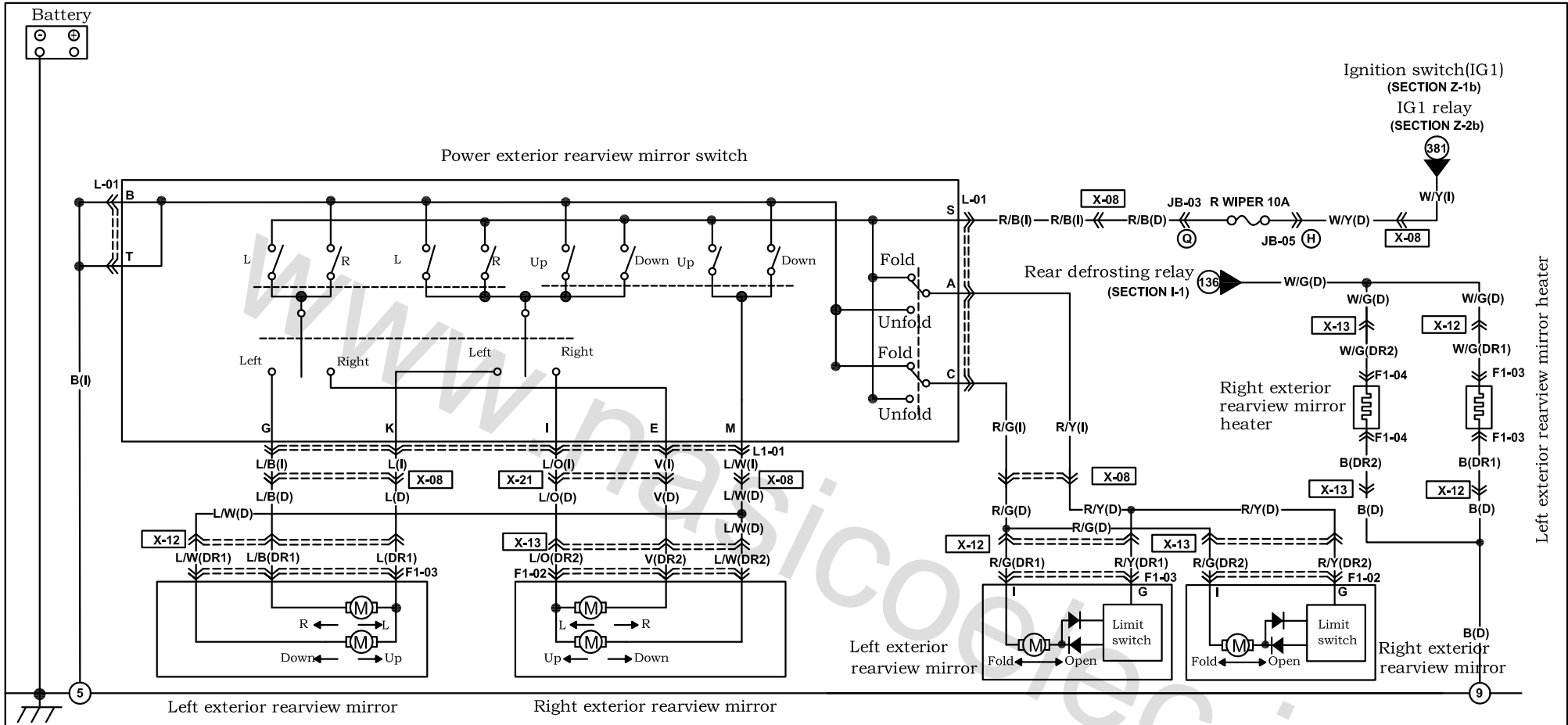

L-01 Integrated switch (I) & with start-stop system

S	Q	O	M	K	I	G	E	C	A
R/B	LG	LG/B	L/W	L	L/O	L/B	V	R/G	R/Y
B	P	G/B	* & P/L	W	*	*	*	*	B
T	R	P	N	L	J	H	F	D	B

F1-03 Left exterior rearview mirror (DR1)

A	*	Y/L	W/G	R/Y	R/G	I
B	*	L	L/W	L/B	B	J

F1-04 Right exterior rearview mirror (DR2)

A	*	Y/B	W/G	R/Y	R/G	I
B	*	L/O	L/W	V	B	J

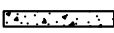

Harness mark:  (F)  (E)  (D)  (R)

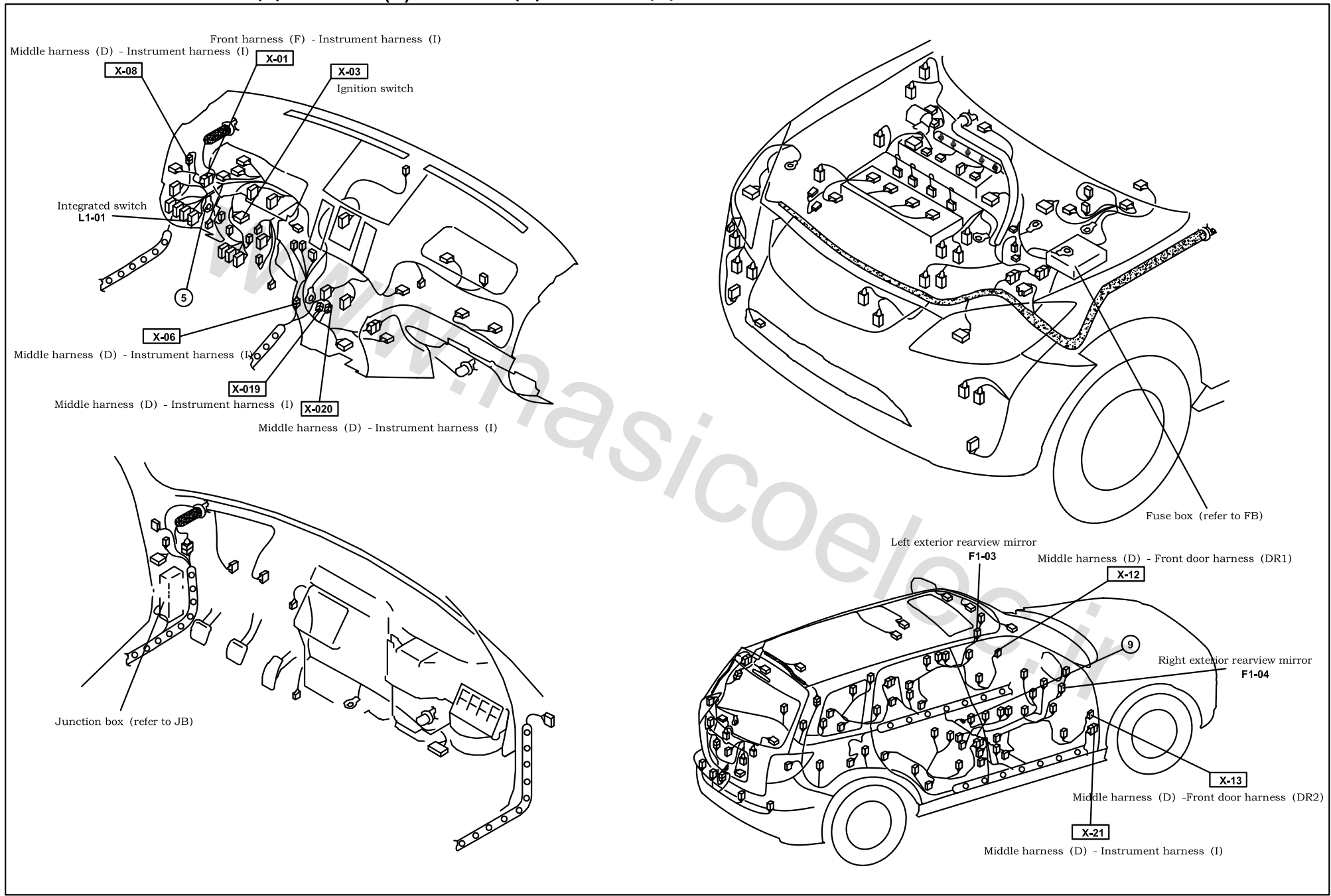

# Sunroof and auto-dimming interior rearview mirror (with tire pressure and reversing distance display)

M

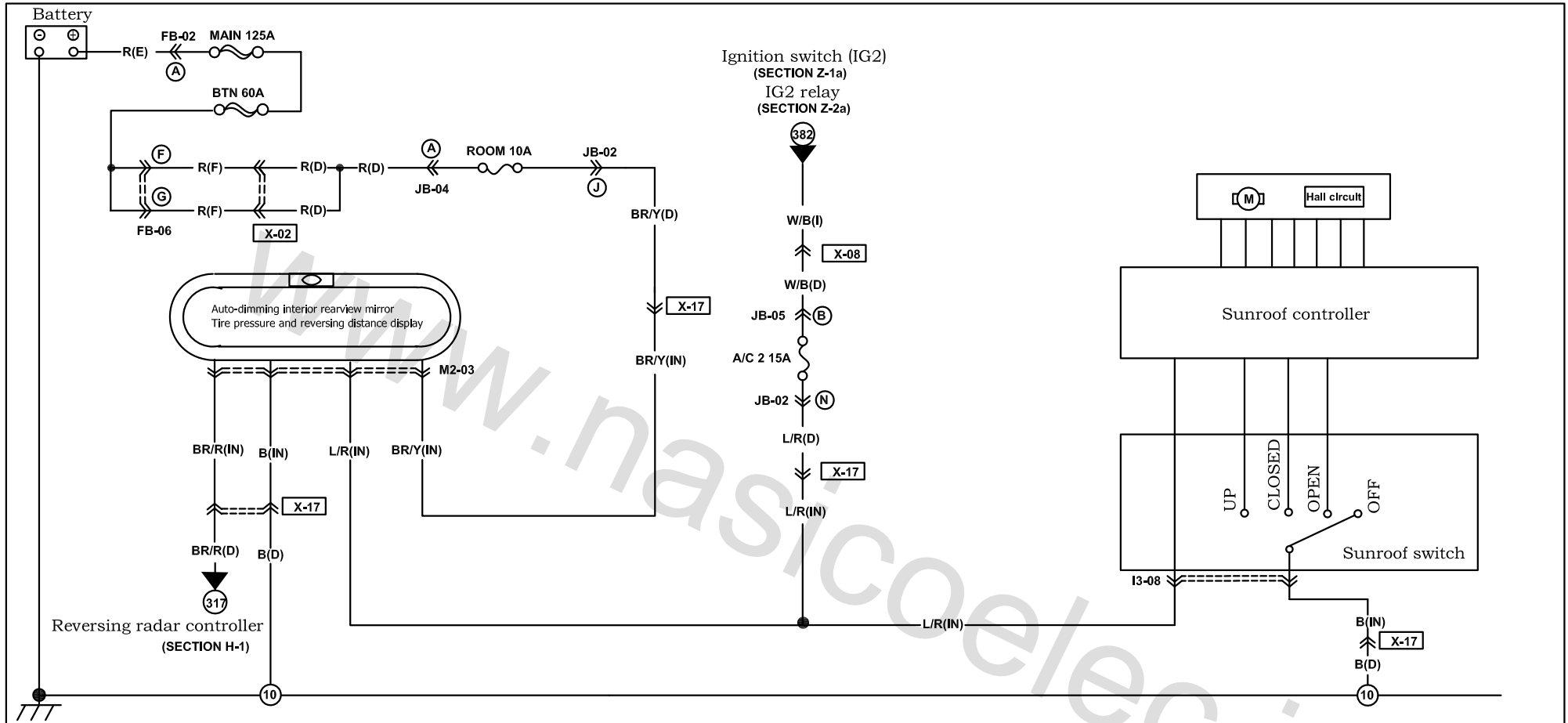

<p><b>I3-08 Sunroof switch (IN)</b></p>	<p><b>M2-03 Auto-dimming interior rearview mirror (IN)</b></p>				

Harness mark:  (F)  (E)  (D)  (R)

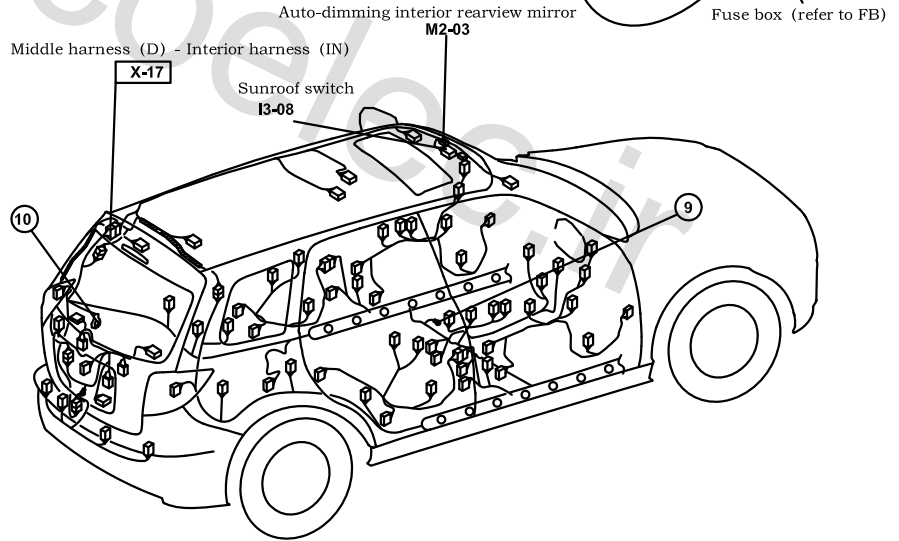
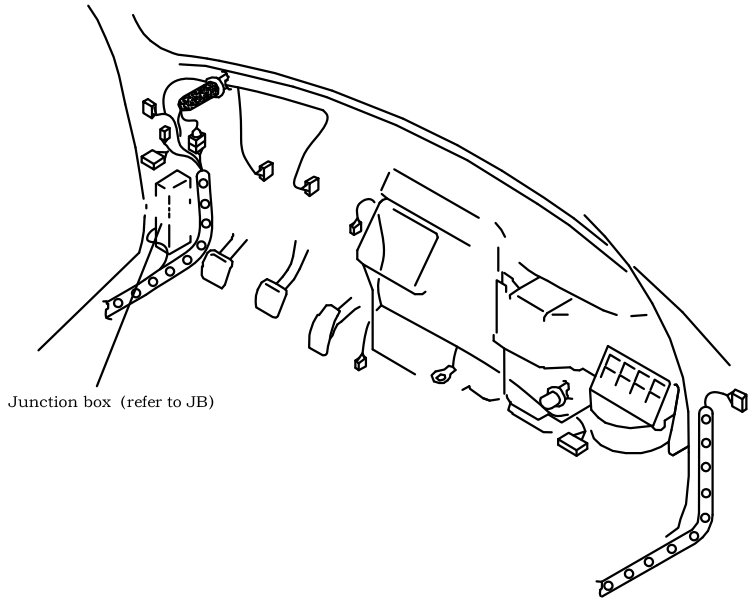
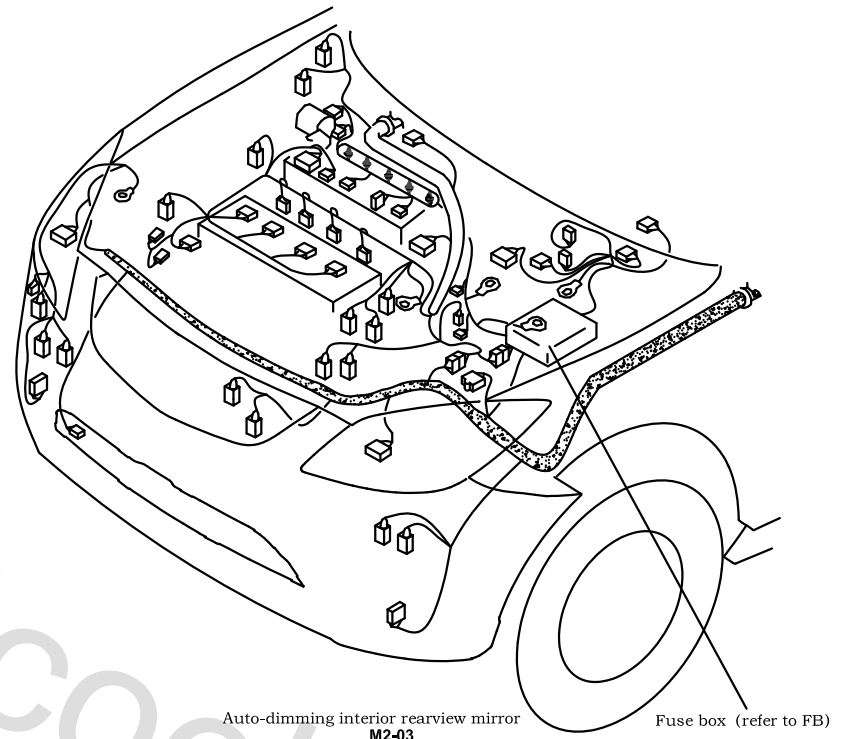
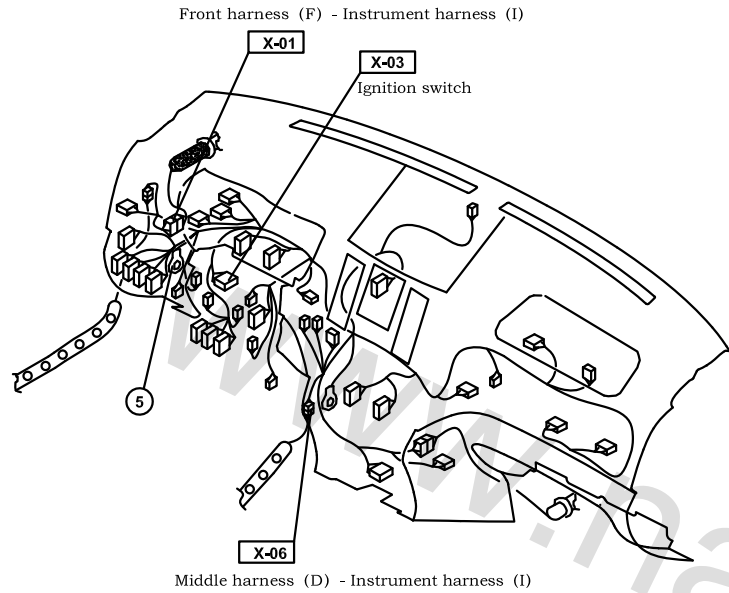

# Anti-lock braking system

# O-1a

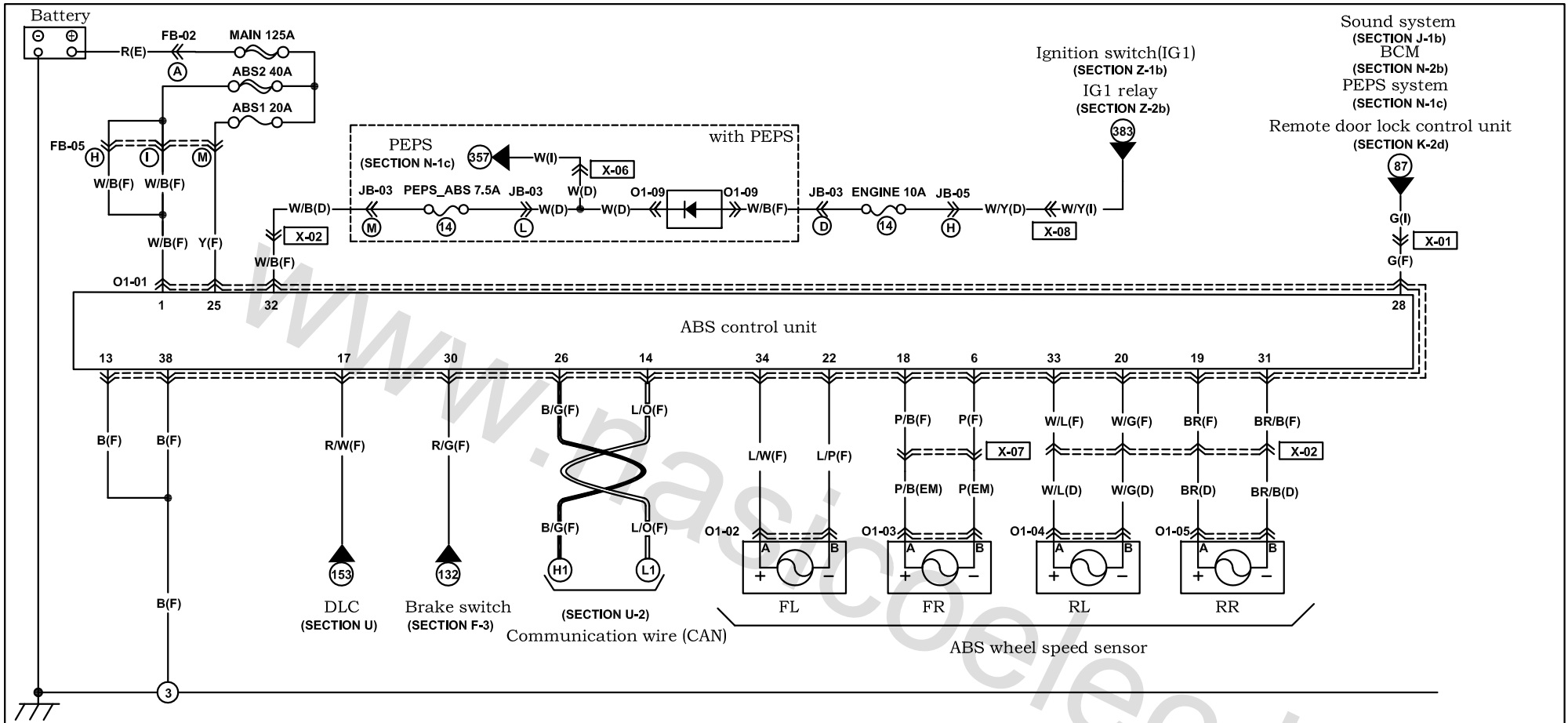

**O1-01** ABS control unit (F)

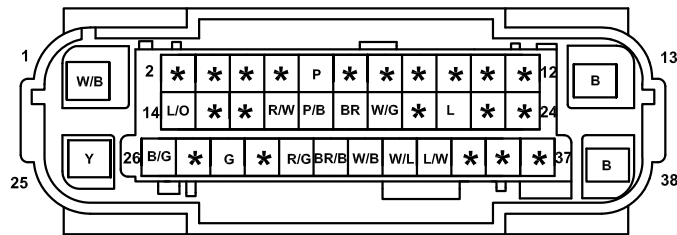

**O1-02** ABS wheel speed sensor FL (EM)



**O1-03** ABS wheel speed sensor FR (EM)



**O1-04** ABS wheel speed sensor RL (D)



**O1-05** ABS wheel speed sensor RR (D)



**O1-09** Diode (D)

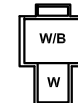

Harness mark:  (F)  (E)  (D)  (R)

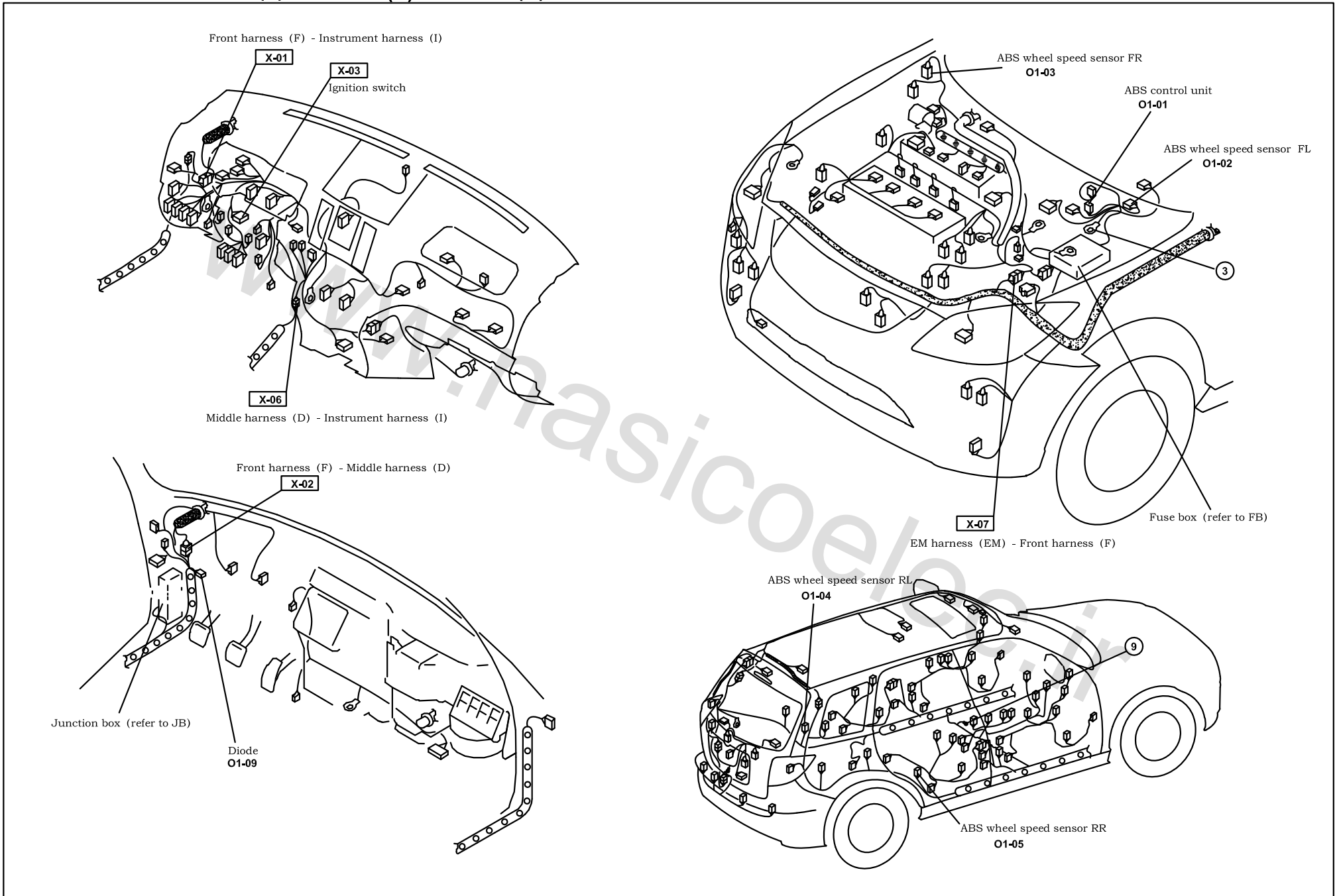

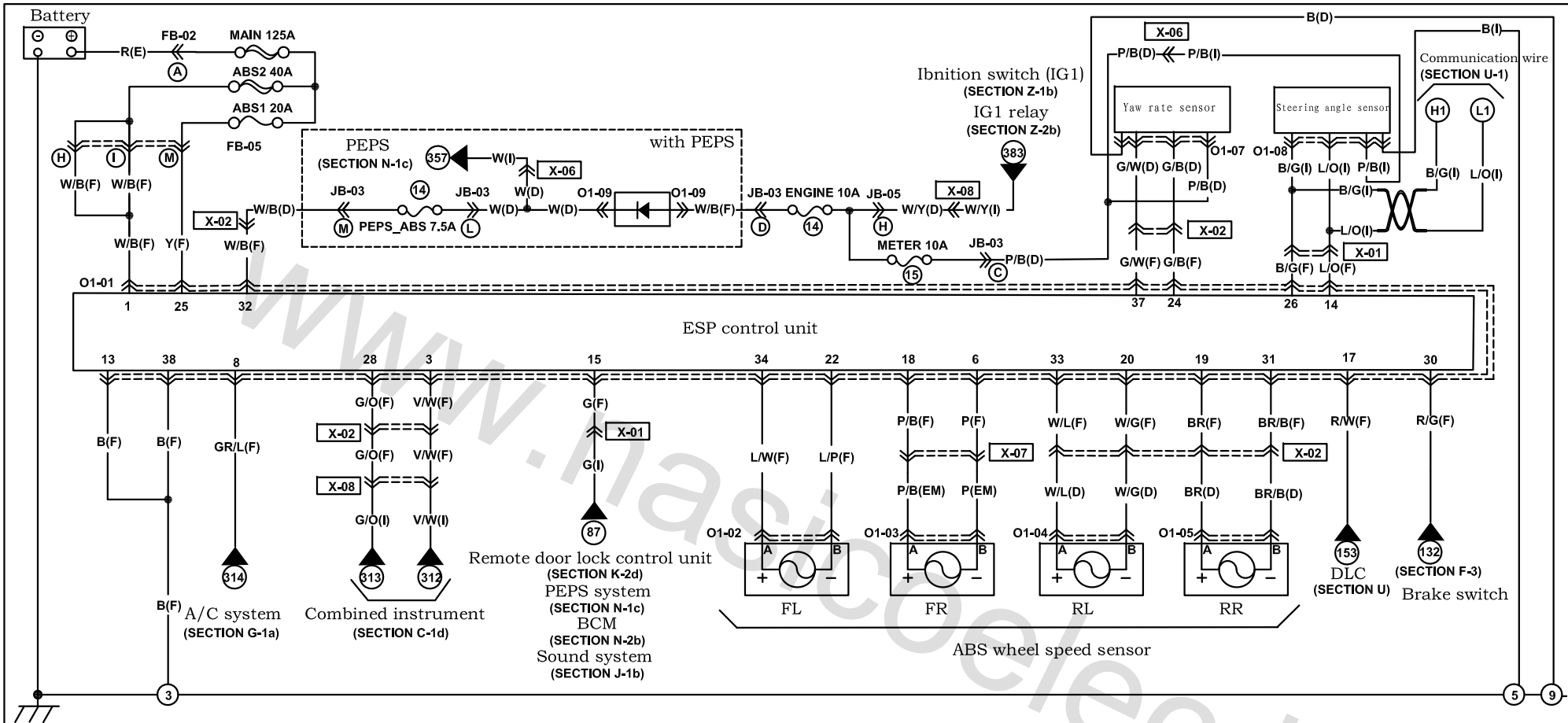

O1-06 ESP control unit (F)

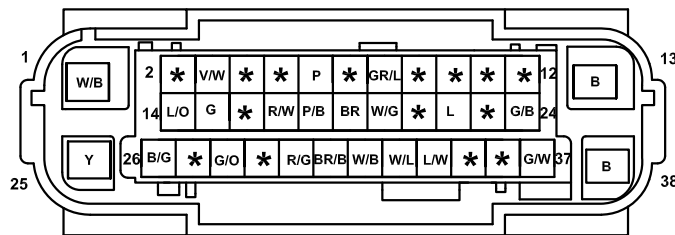

O1-02 ABS wheel speed sensor FL (EM)



O1-04 ABS wheel speed sensor RL (D)



O1-09 Diode (D)

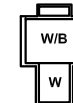

O1-03 ABS wheel speed sensor FR (EM)



O1-05 ABS wheel speed sensor RR (D)



O1-07 Yaw rate sensor (D)

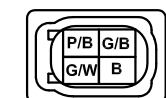

O1-08 Steering angle sensor (I)

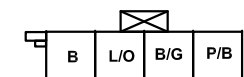

Harness mark:  (F)  (E)  (D)  (R)

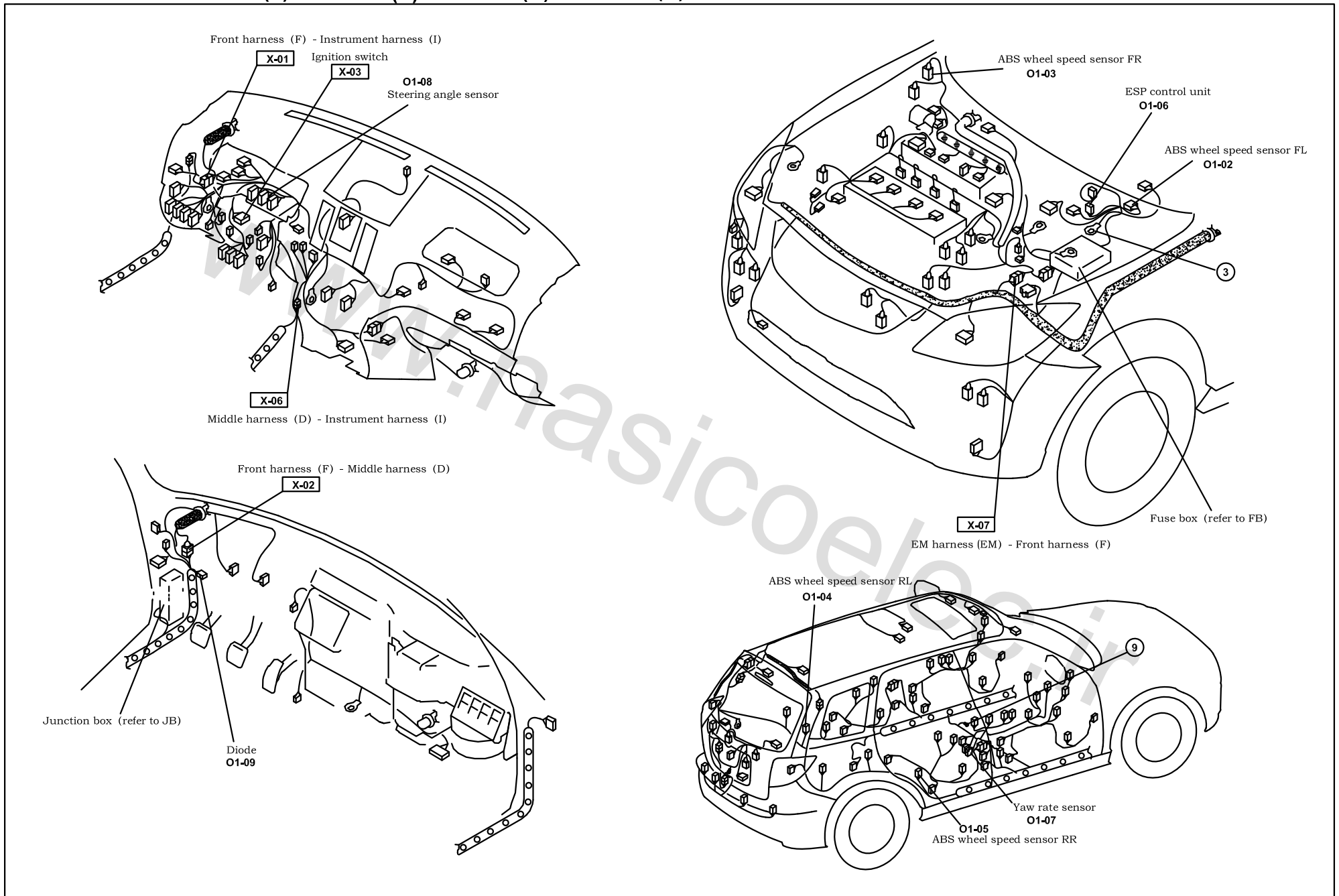

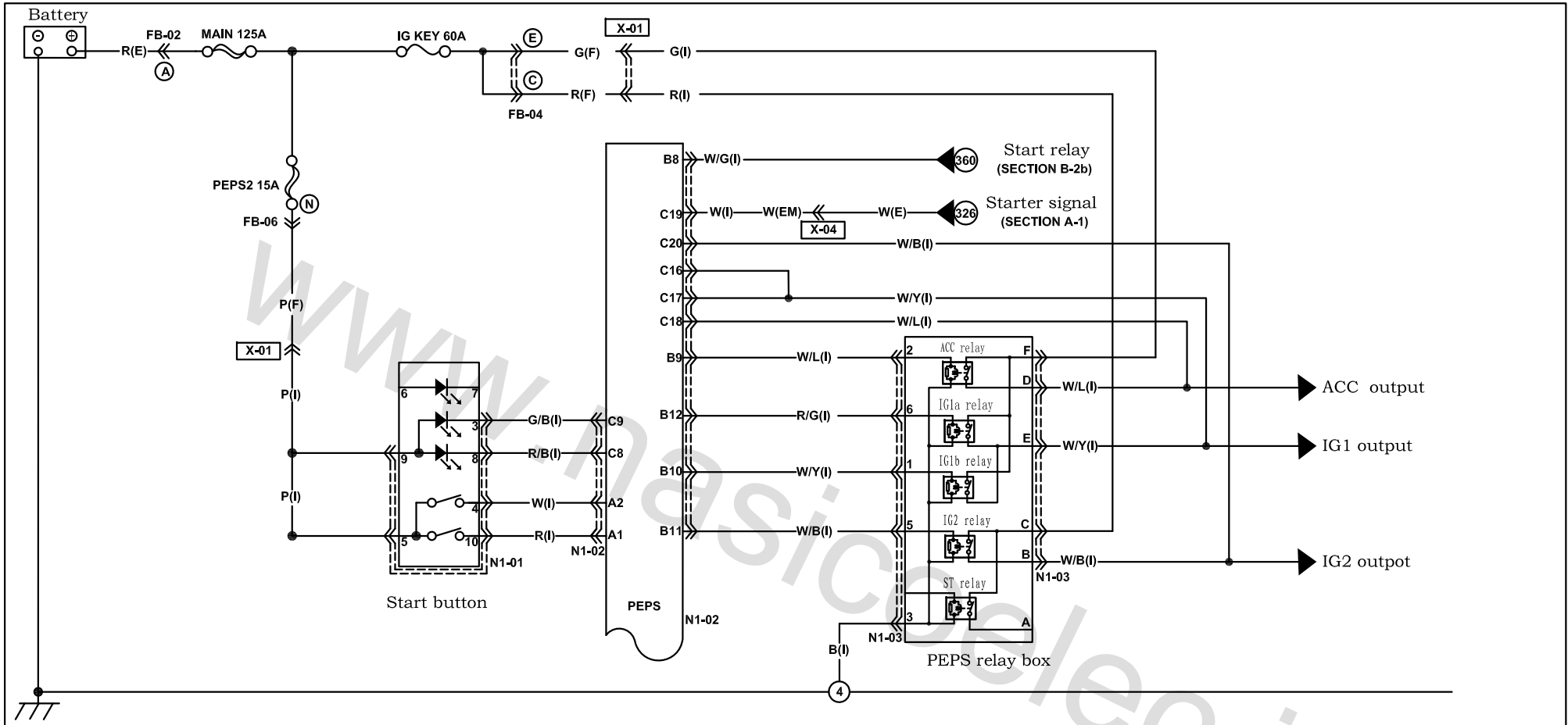

N1-01 Start button (I)

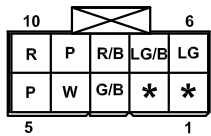

N1-02 PEPS controller (I)

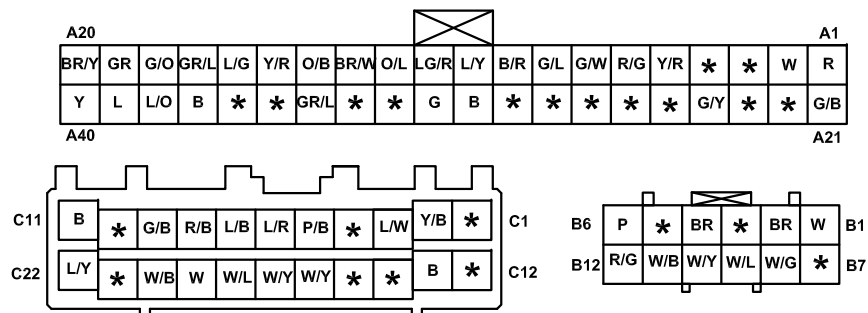

N1-03 PEPS relay box (I)

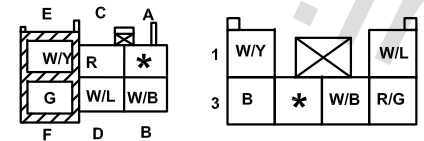



Harness mark:  (F)  (E)  (D)  (R)

Front harness (F) - Instrument harness (I)  
Middle harness (D) - Instrument harness (I)

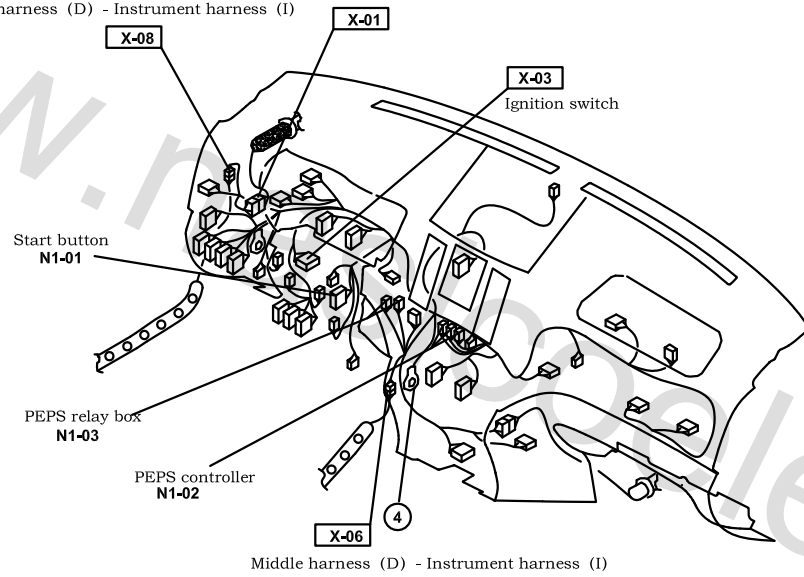

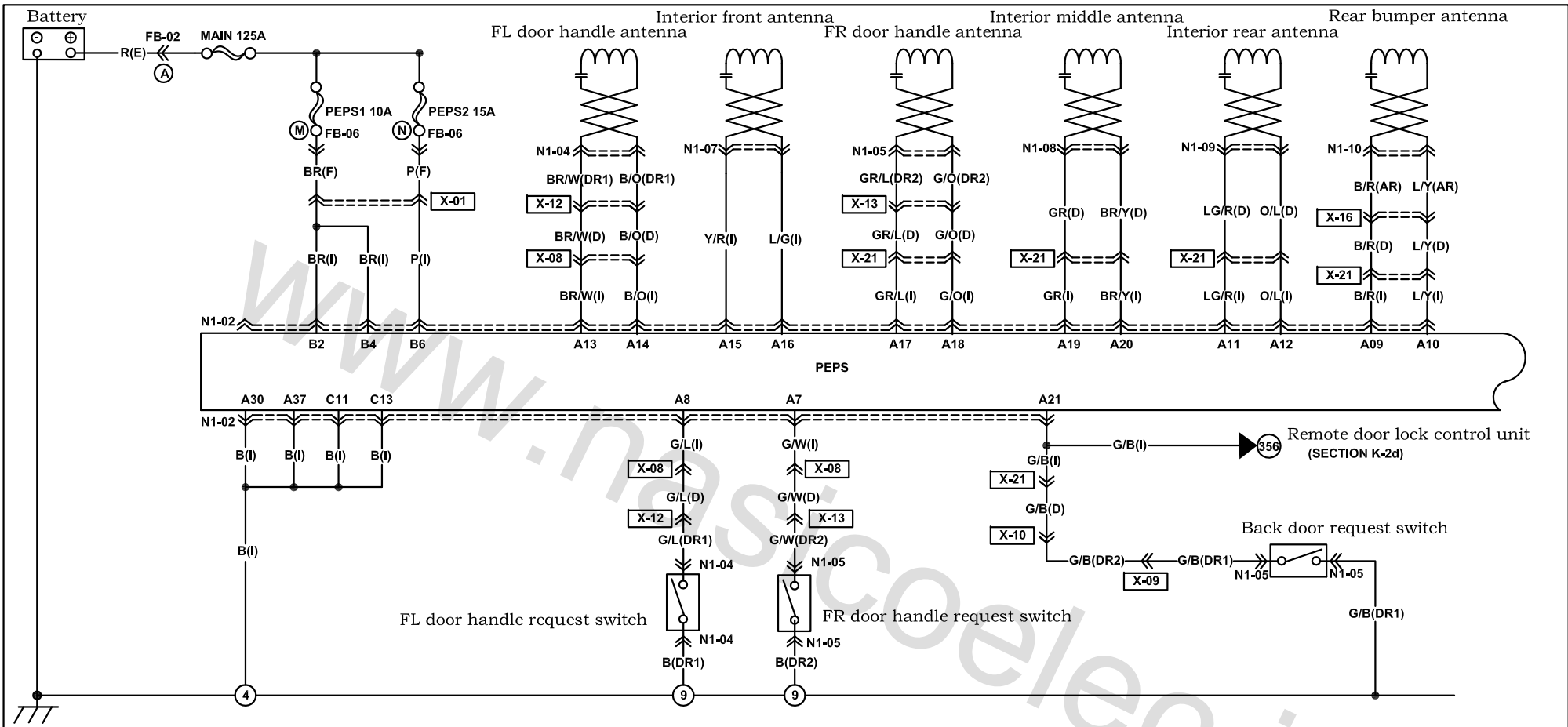

N1-02 PEPS controller (I)

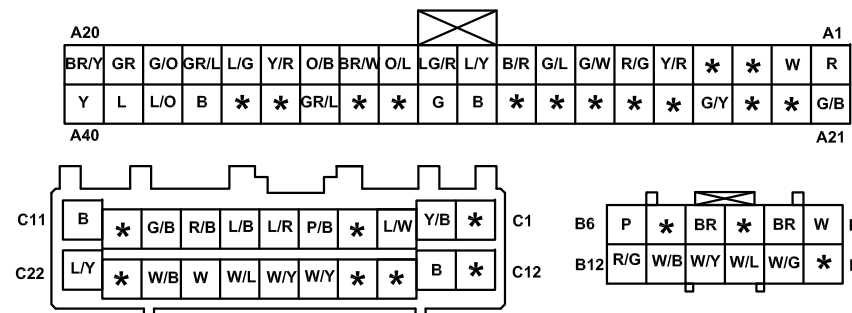

N1-04 FL door handle request switch(DR1)

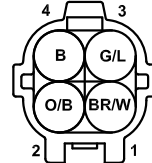

N1-05 FR door handle request switch(DR2)

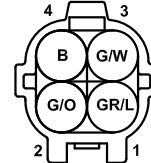

N1-05 Back door request switch (R1#)

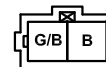

N1-07 Interior front antenna(I)

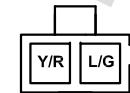

N1-08 Interior middle antenna(D)

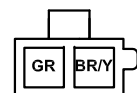

N1-09 Interior rear antenna(D)

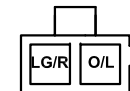

N1-10 Rear bumper antenna(AR)

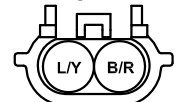

Harness mark:  (F)  (E)  (D)  (R)

Front harness (F) - Instrument harness (I)  
Middle harness (D) - Instrument harness (I)

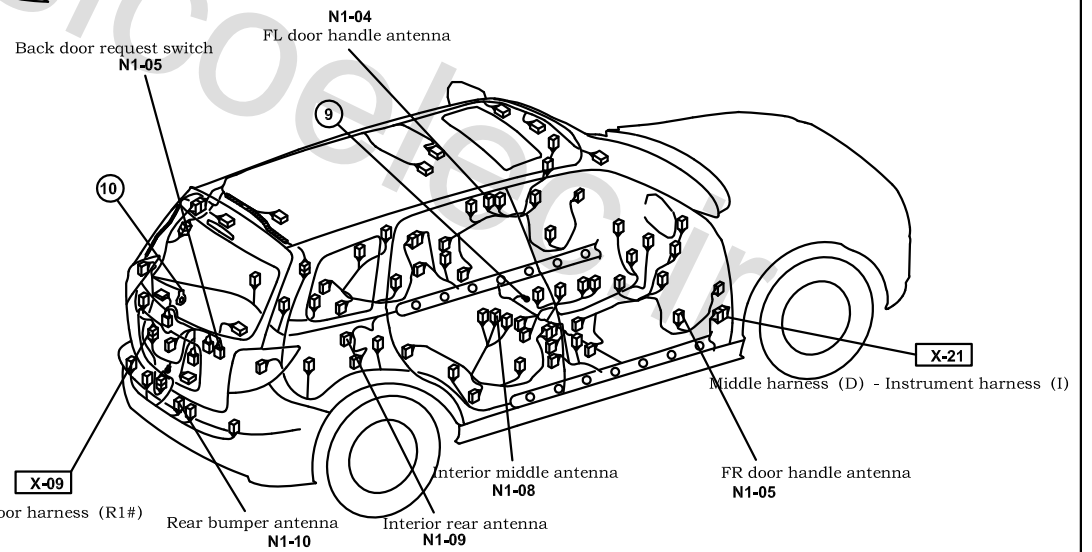
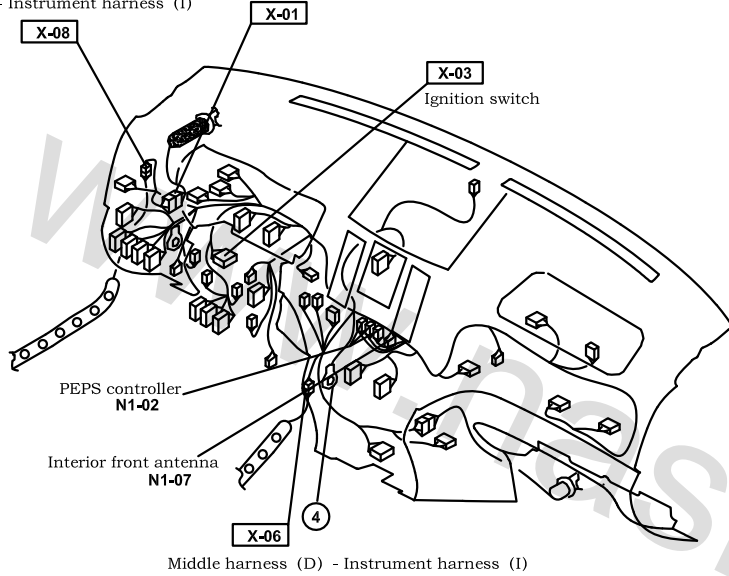

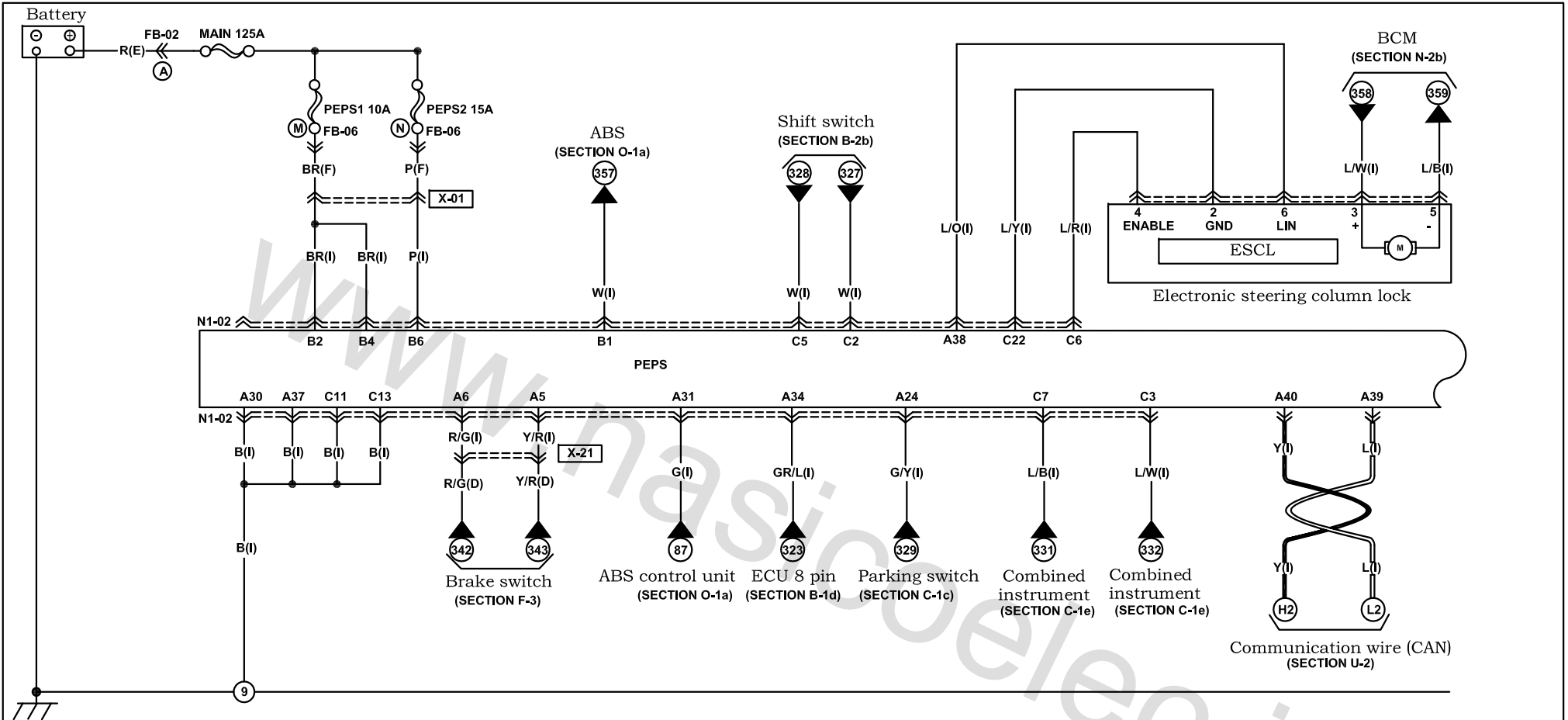

N1-02 PEPS controller (I)

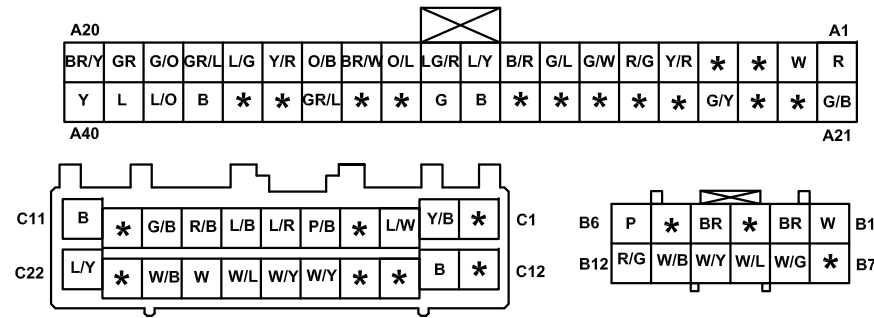

N1-11 Electronic steering column lock (I)

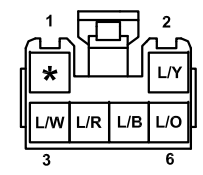

Harness mark:  (F)  (E)  (D)  (R)

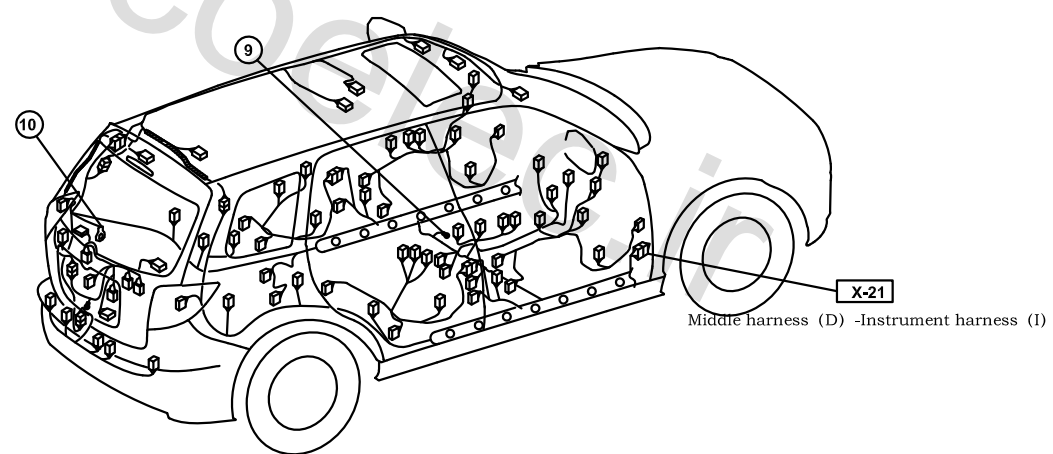
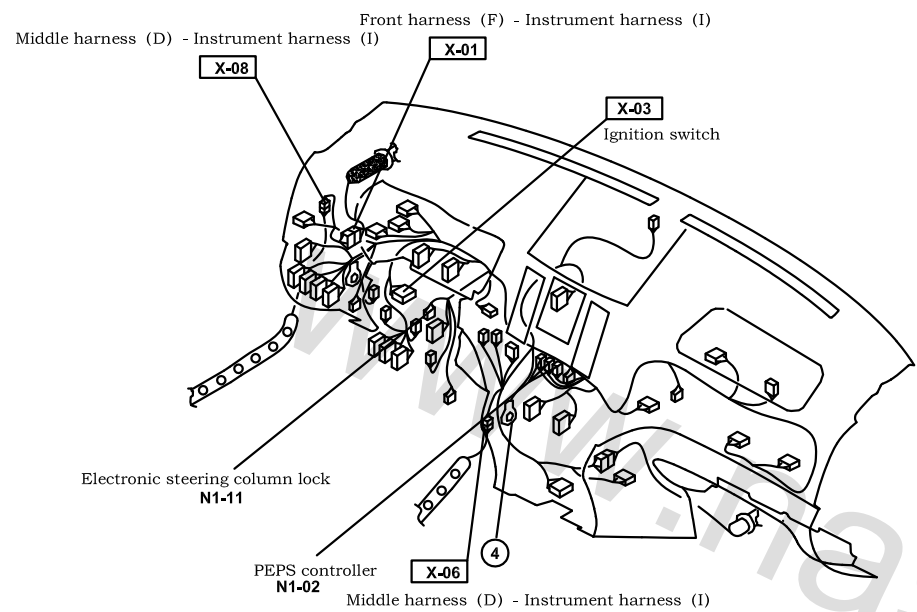

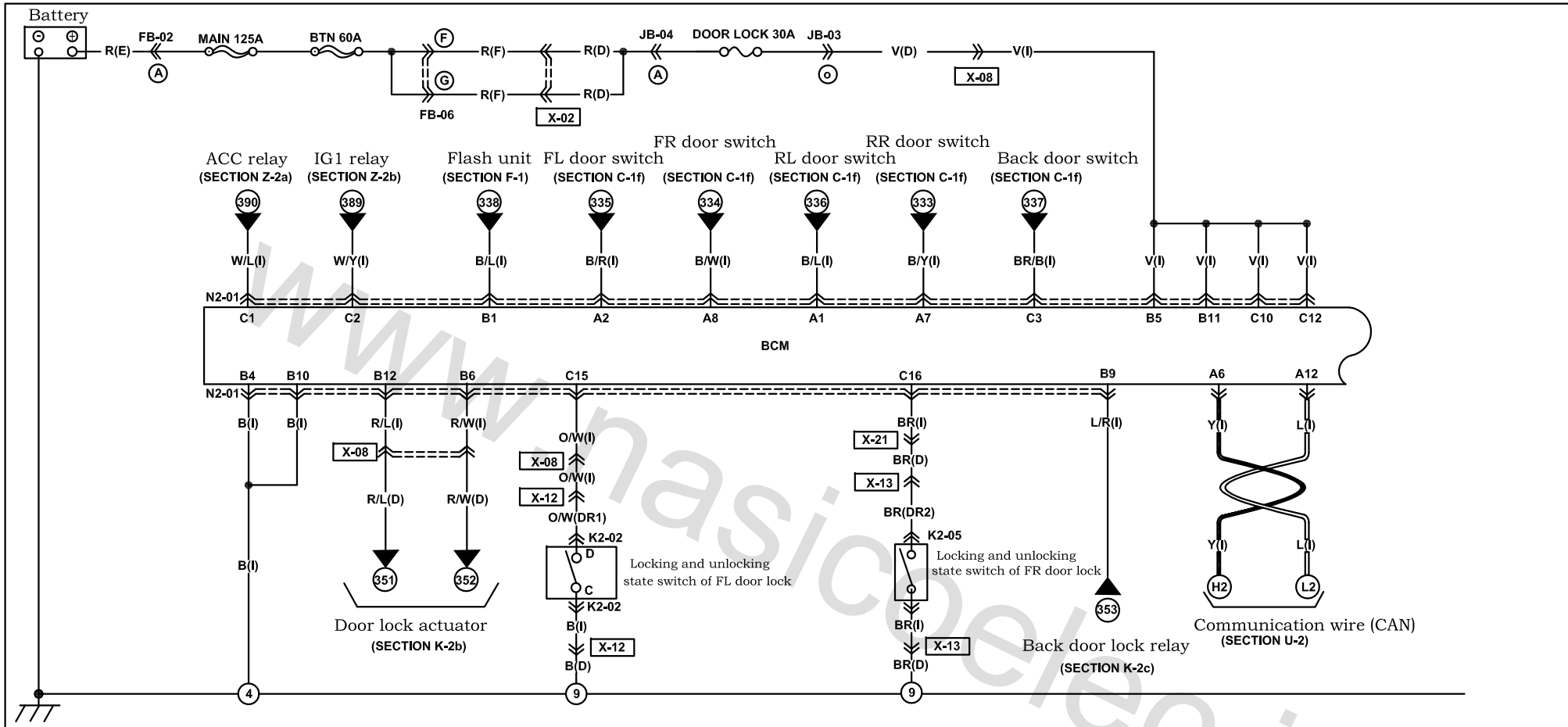

N2-01 Body control system (BCM) (I)

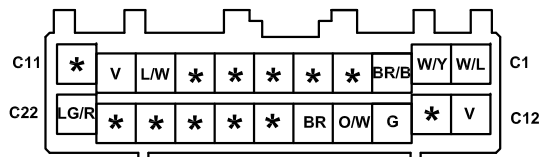
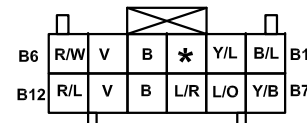



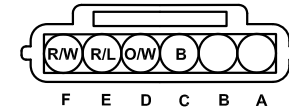

K2-02 FL door lock actuator (DR1)

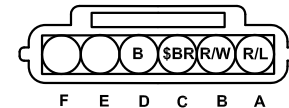

K2-05 FR door lock actuator (DR2)

\$ with PEPS

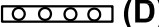

Harness mark:  (F)  (E)  (D)  (R)

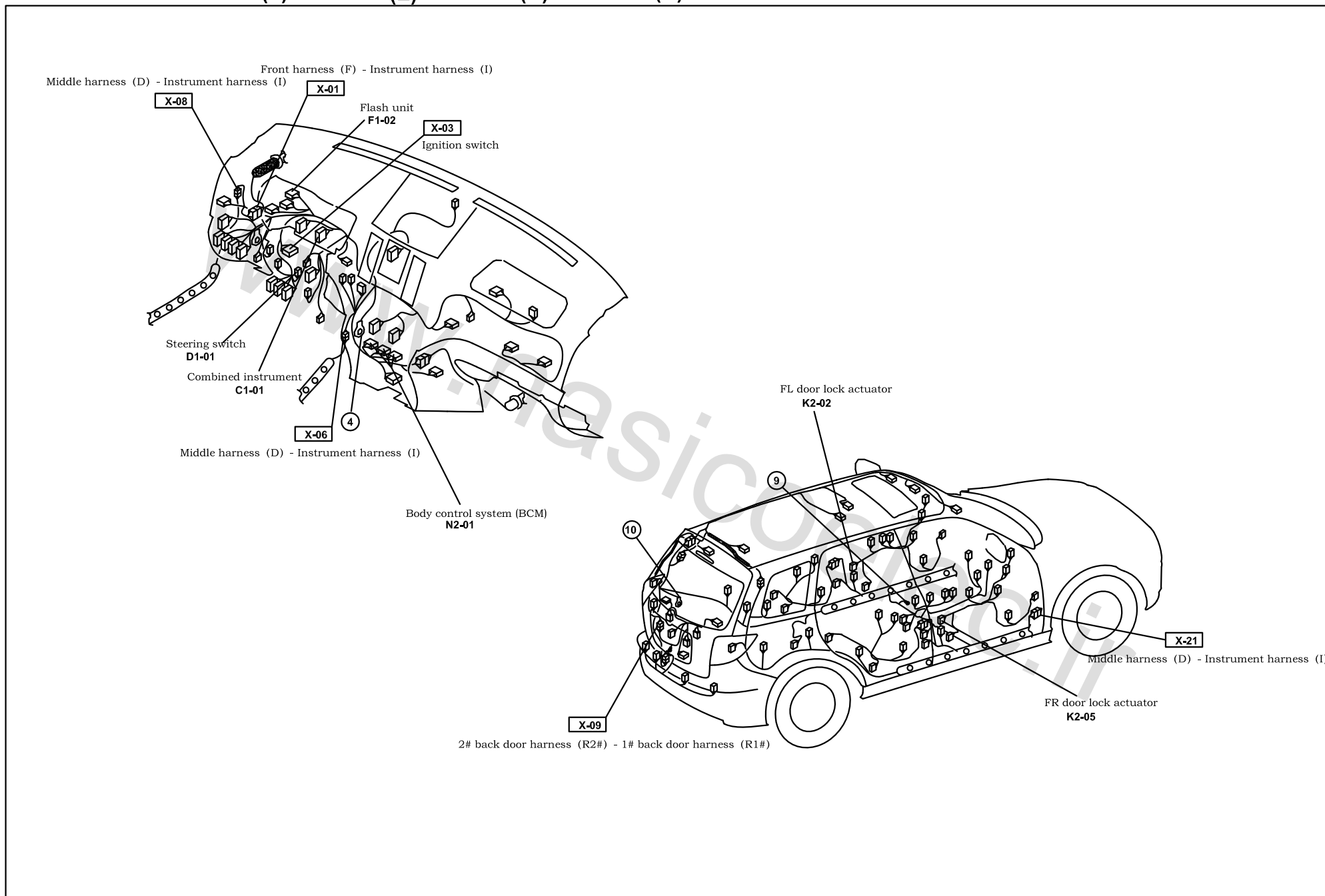

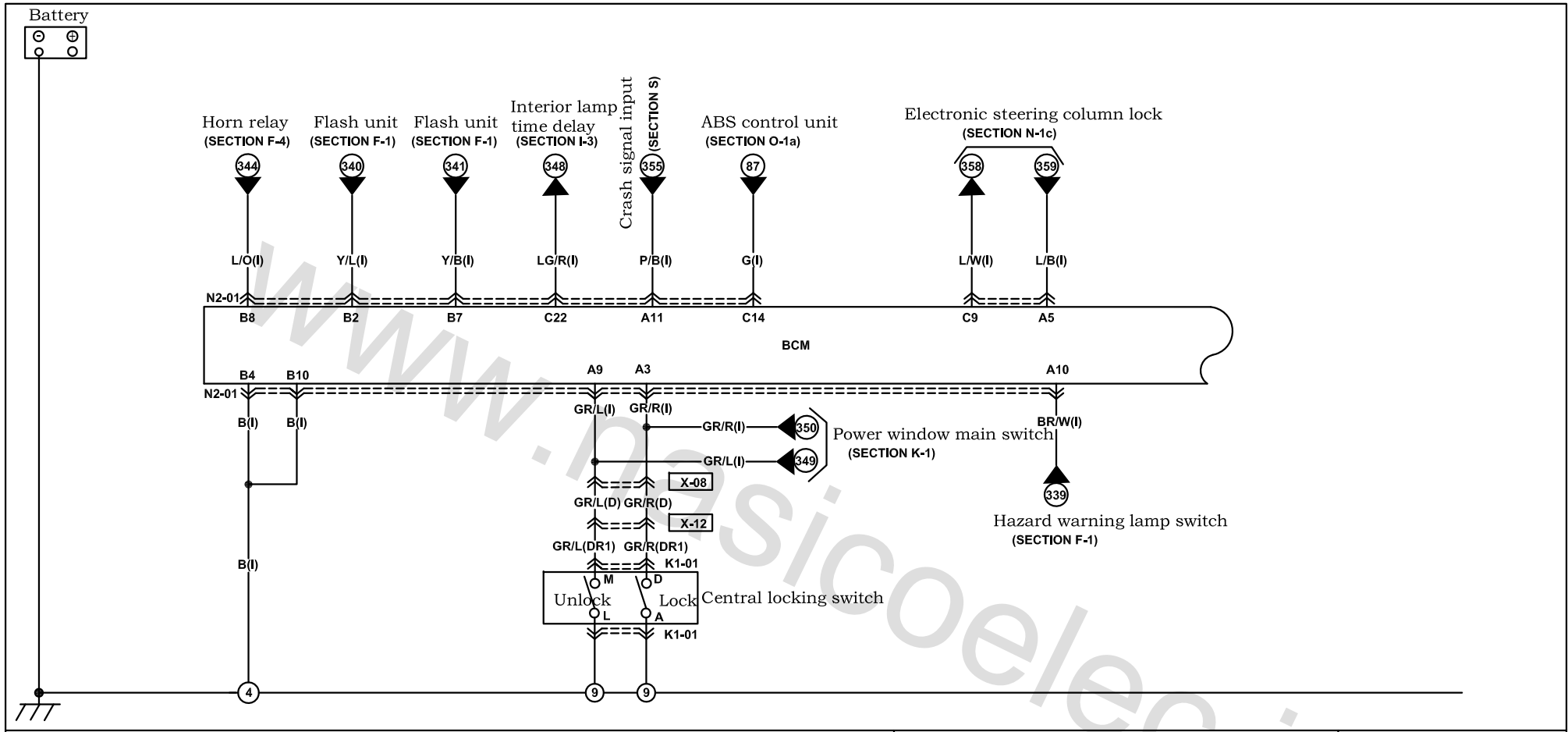

N2-01 Body control module (BCM)(I)

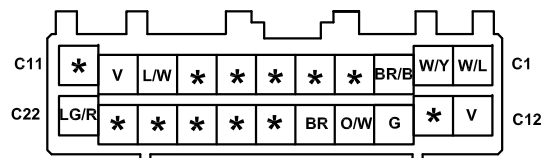
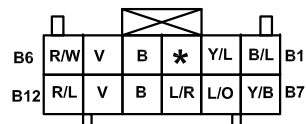

K1-01 Power window main switch (DR1)

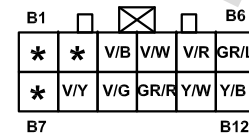



Harness mark:  (F)  (E)  (D)  (R)

Middle harness (D) - Instrument harness (I)      Front harness (F) - Instrument harness (I)

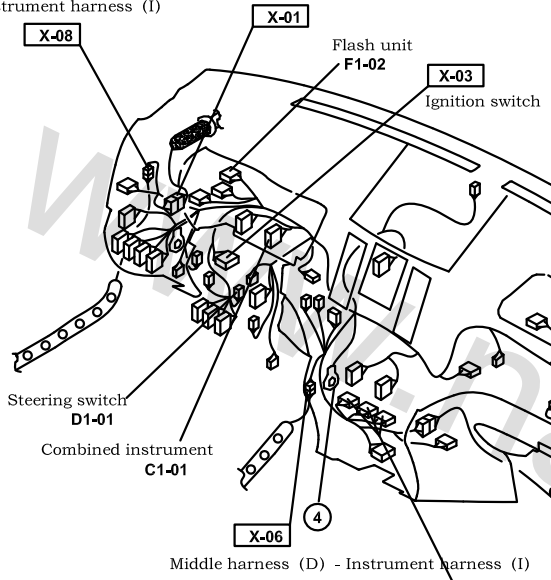

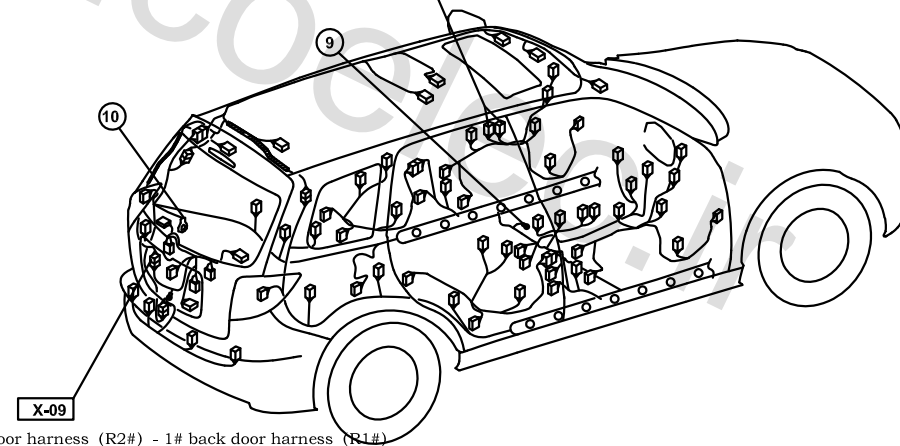

Body control system (BCM)  
N2-01

K1-01  
Power window main switch

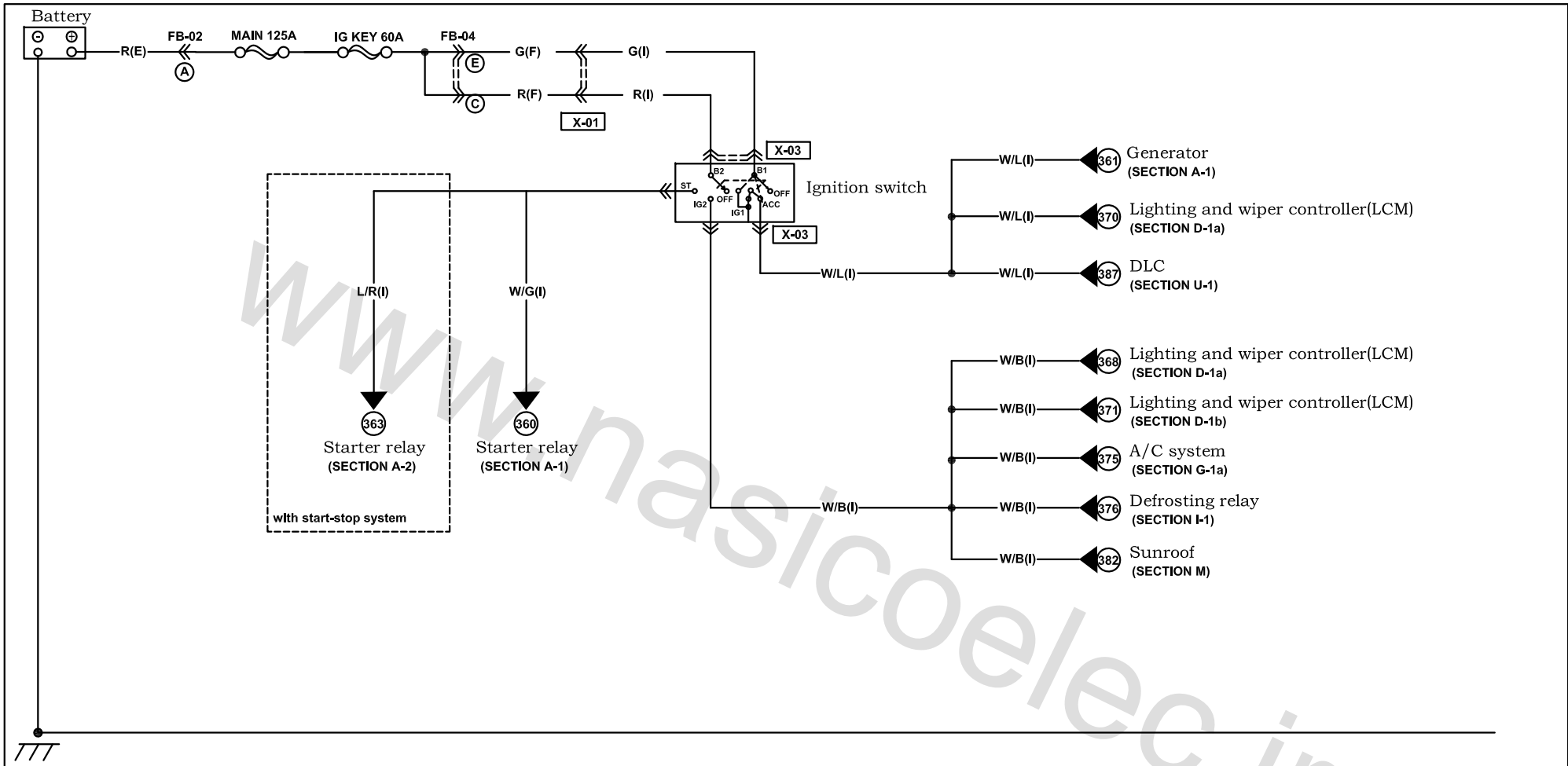

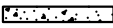

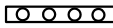
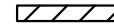

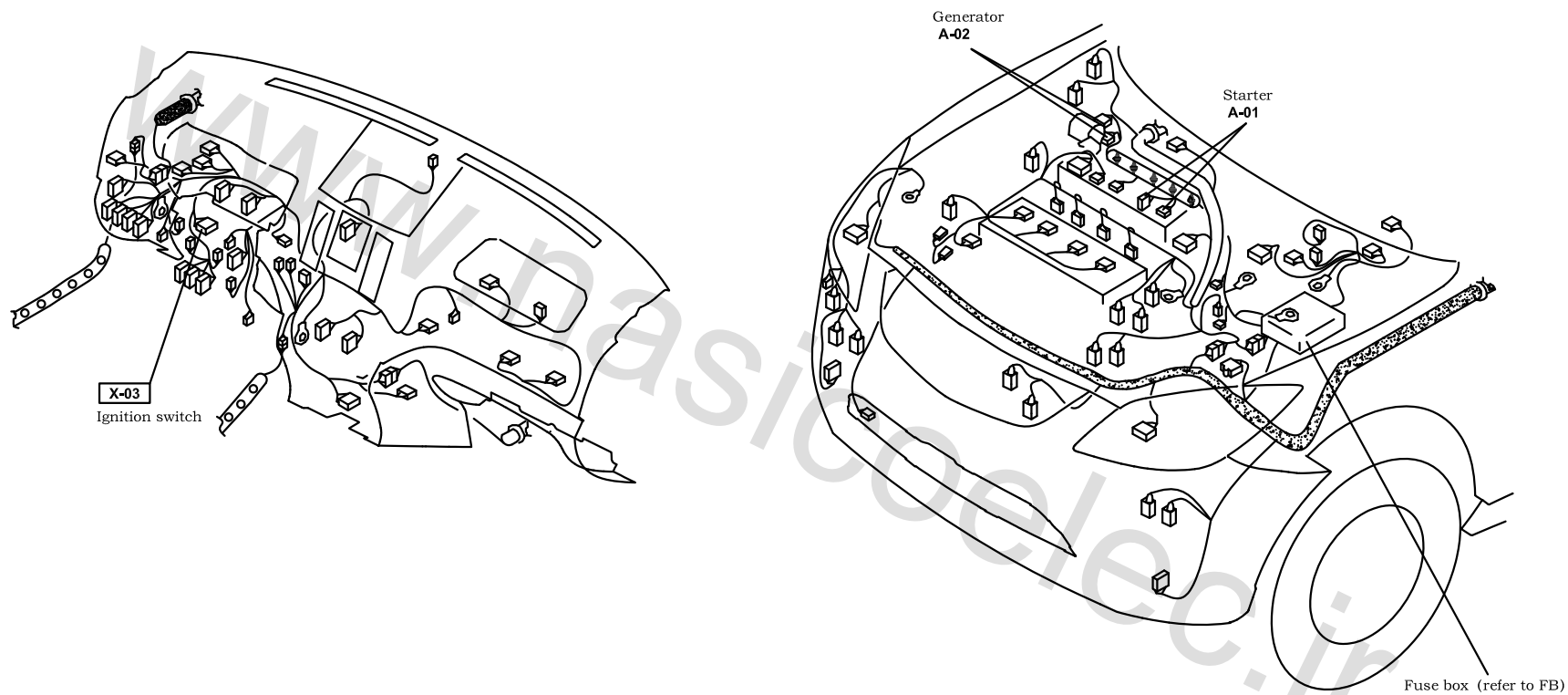
Harness mark:  (F)  (E)  (D)  (R)

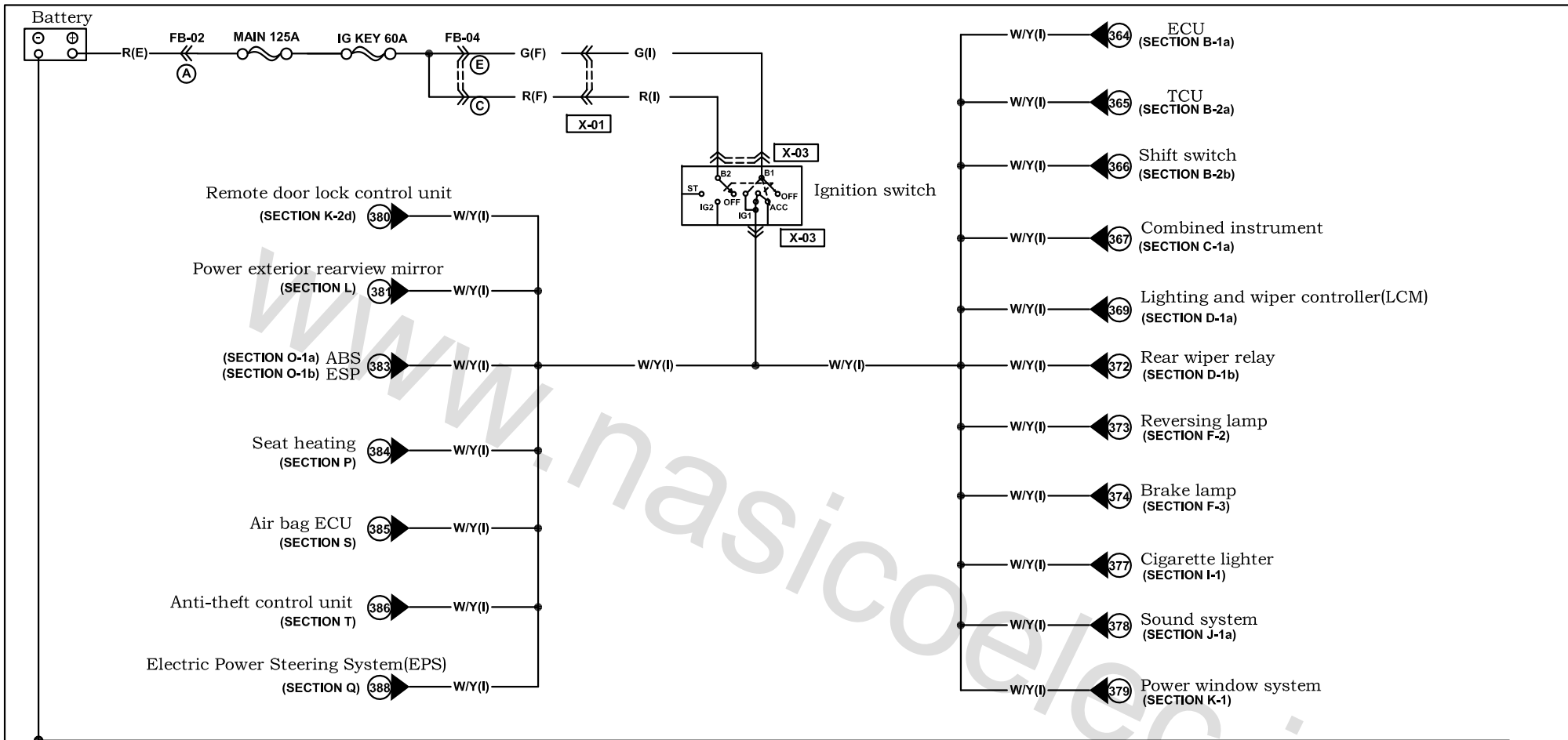



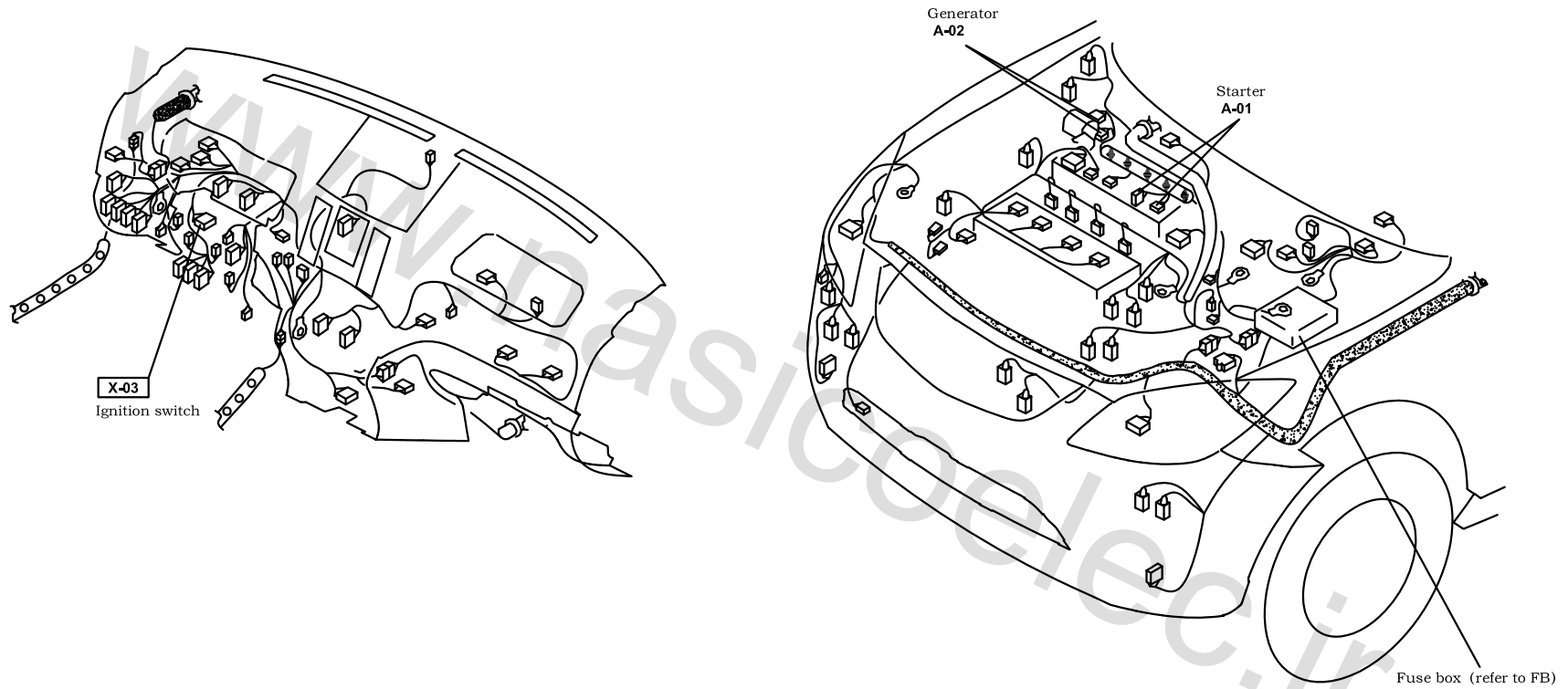

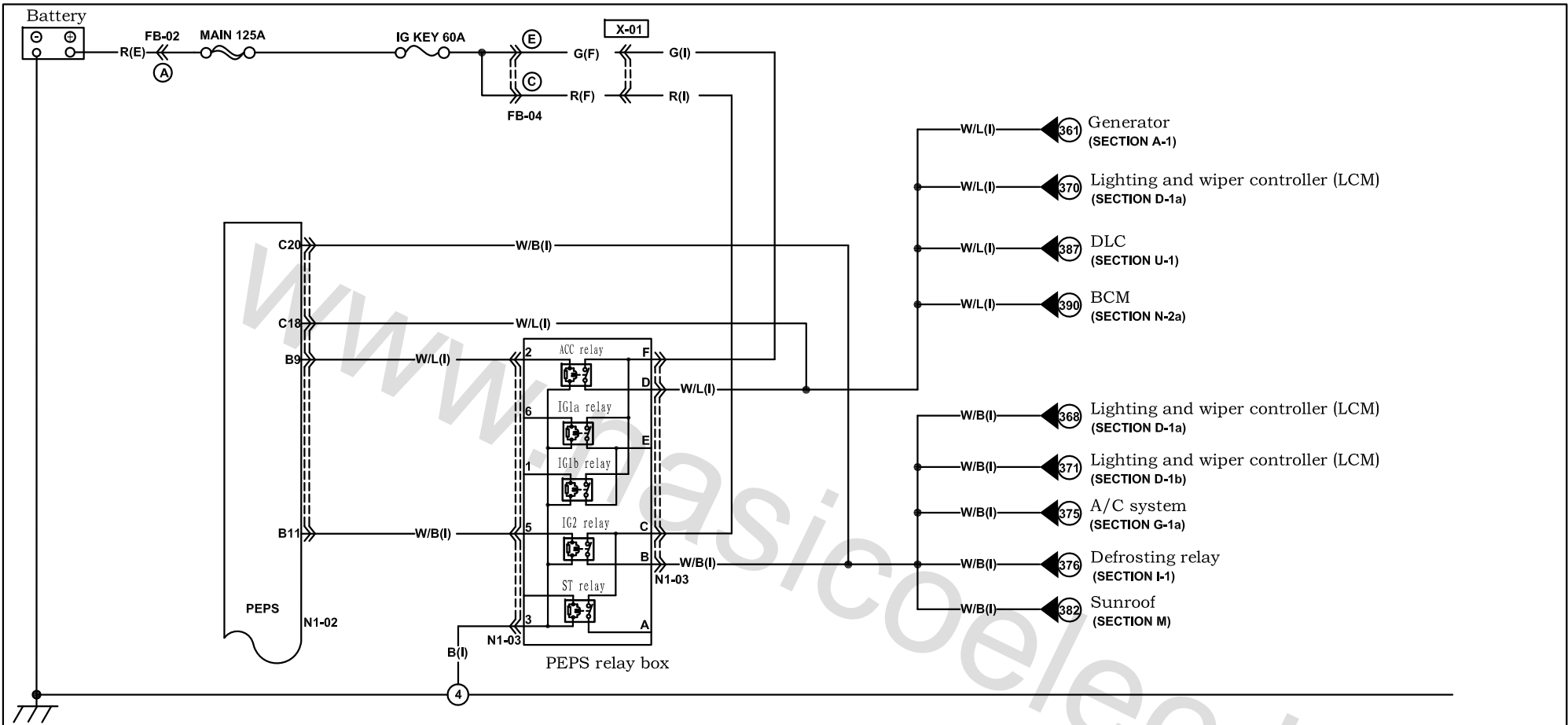
Harness mark:  (F)  (E)  (D)  (R)



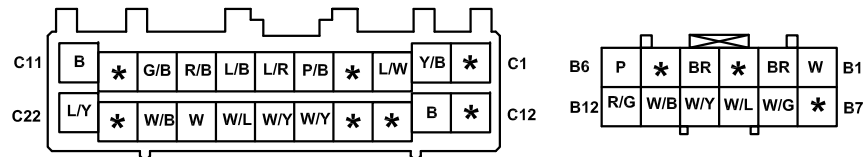
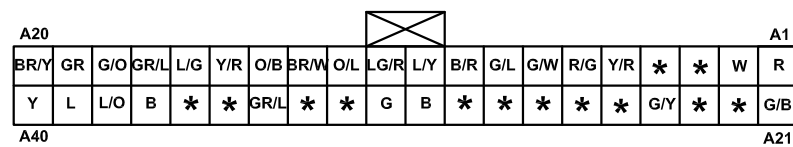

N1-02 PEPS controller (I)



N1-03 PEPS relay box (I)

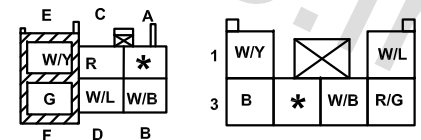

Harness mark:  (F)  (E)  (D)  (R)

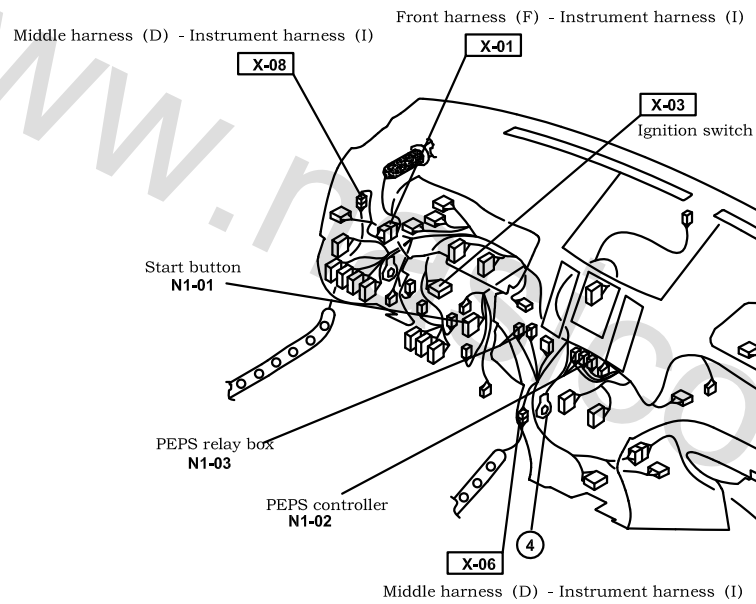

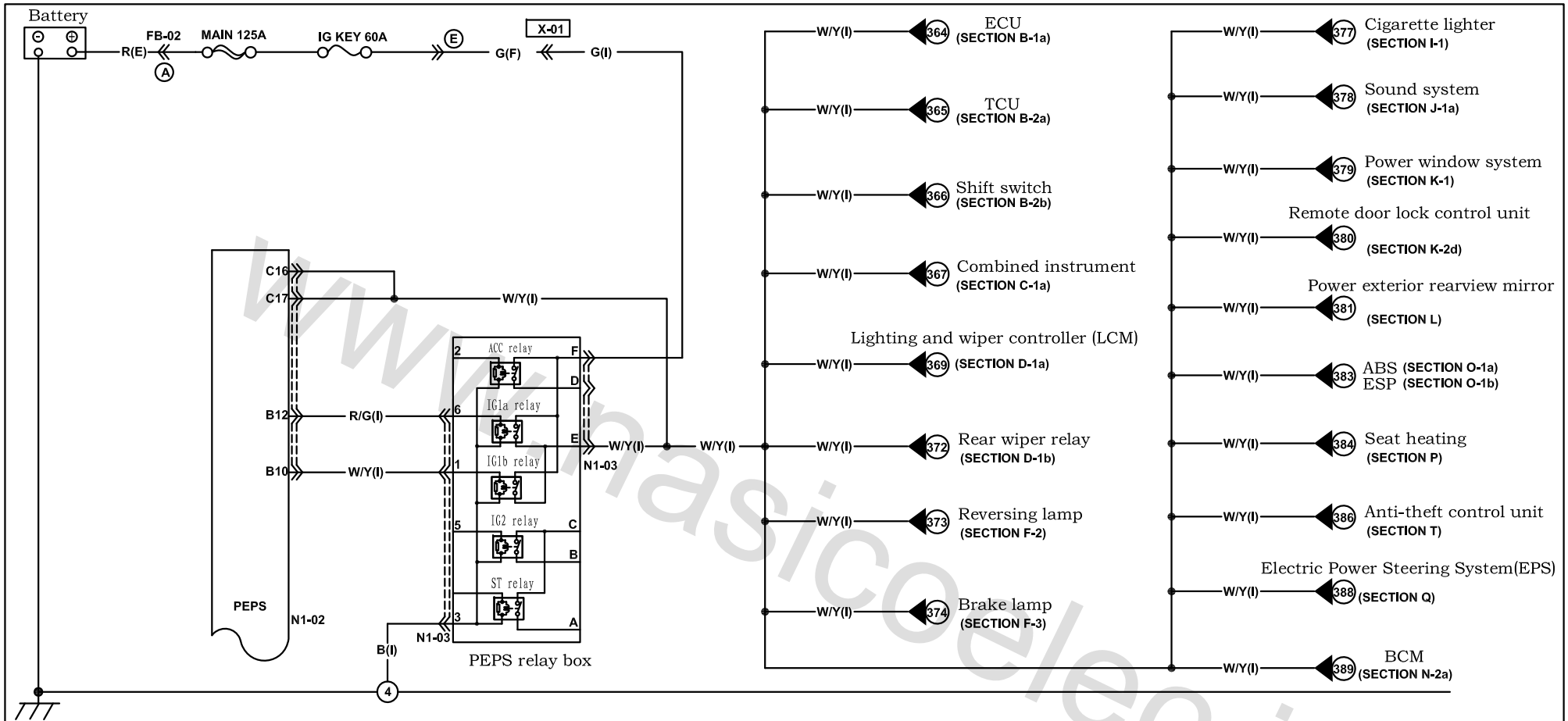



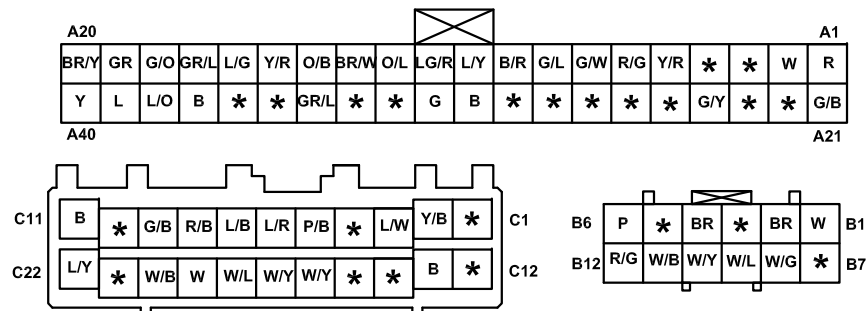

N1-02 PEPS controller (l)

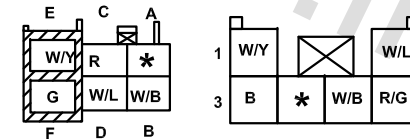

N1-03 PEPS relay box (l)







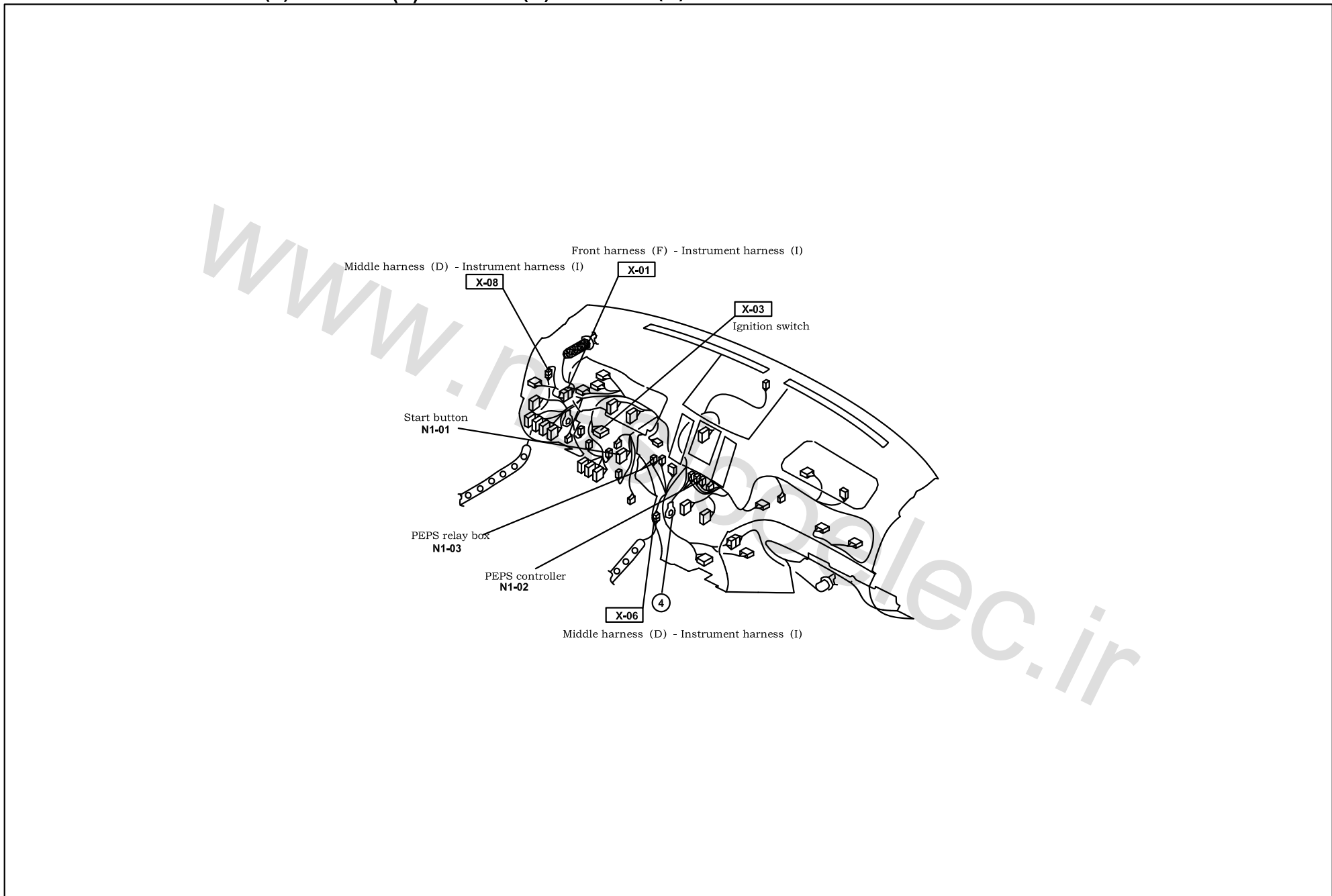



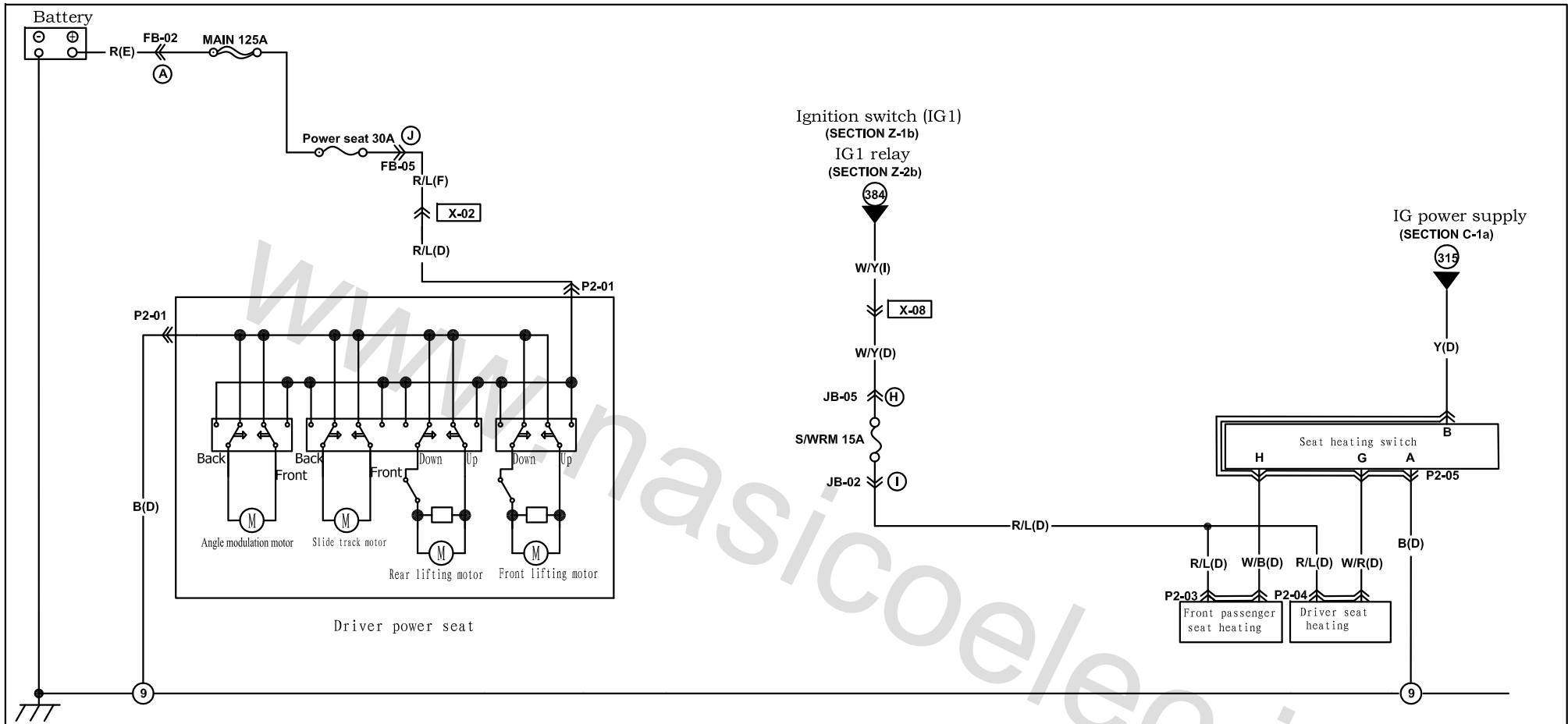

Harness mark:  (F)  (E)  (D)  (R)

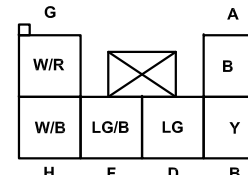

# Power seat and seat heating



<p><b>P2-01</b> Driver power seat (D)</p> 		<p><b>P2-05</b> Seat heating switch (D)</p> 				
<p><b>P2-03</b> Driver seat heating (D)</p> 	<p><b>P2-04</b> Front passenger seat heating (D)</p> 					

Harness mark:  (F)  (E)  (D)  (R)

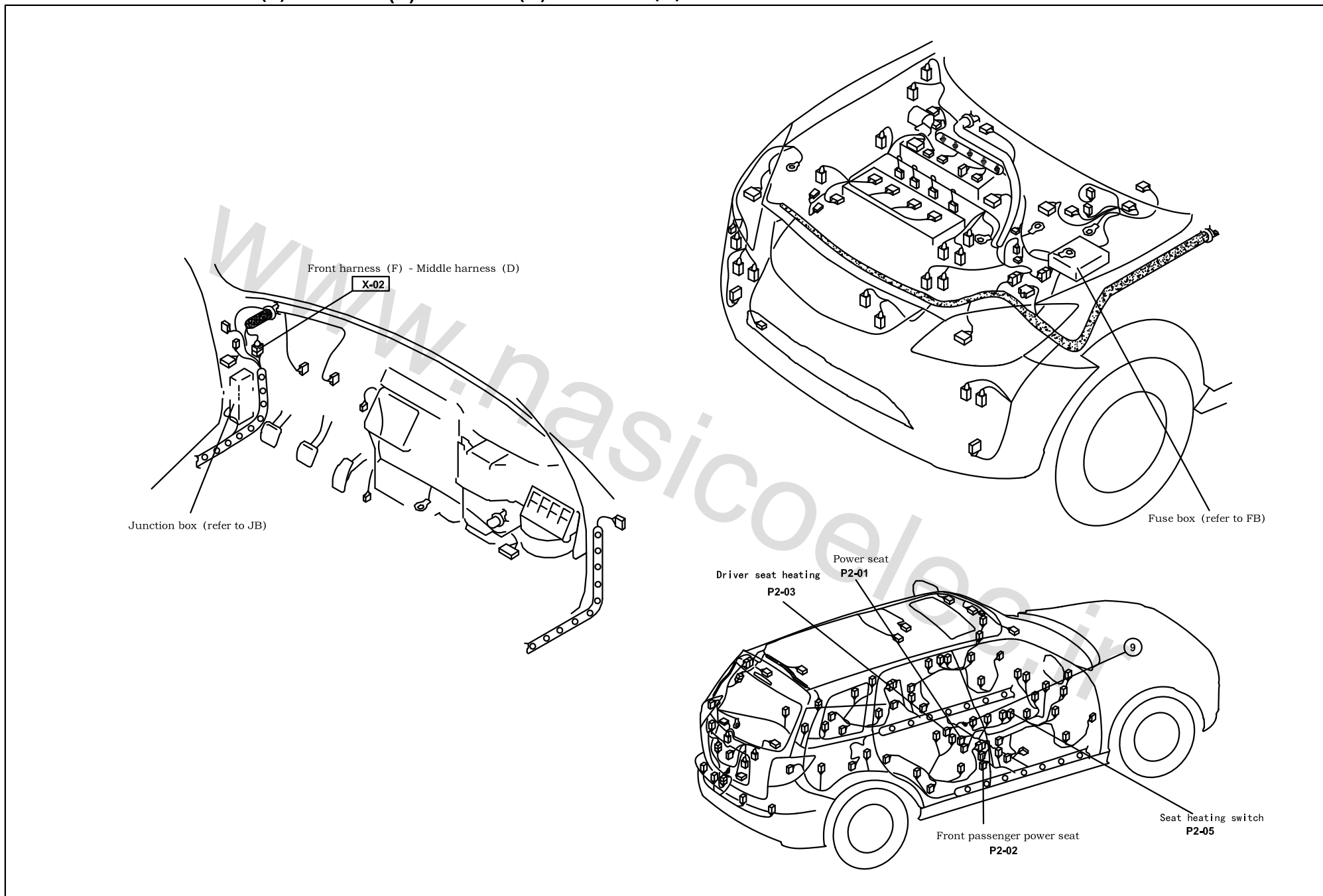

# Electric Power Steering System (EPS)

Q

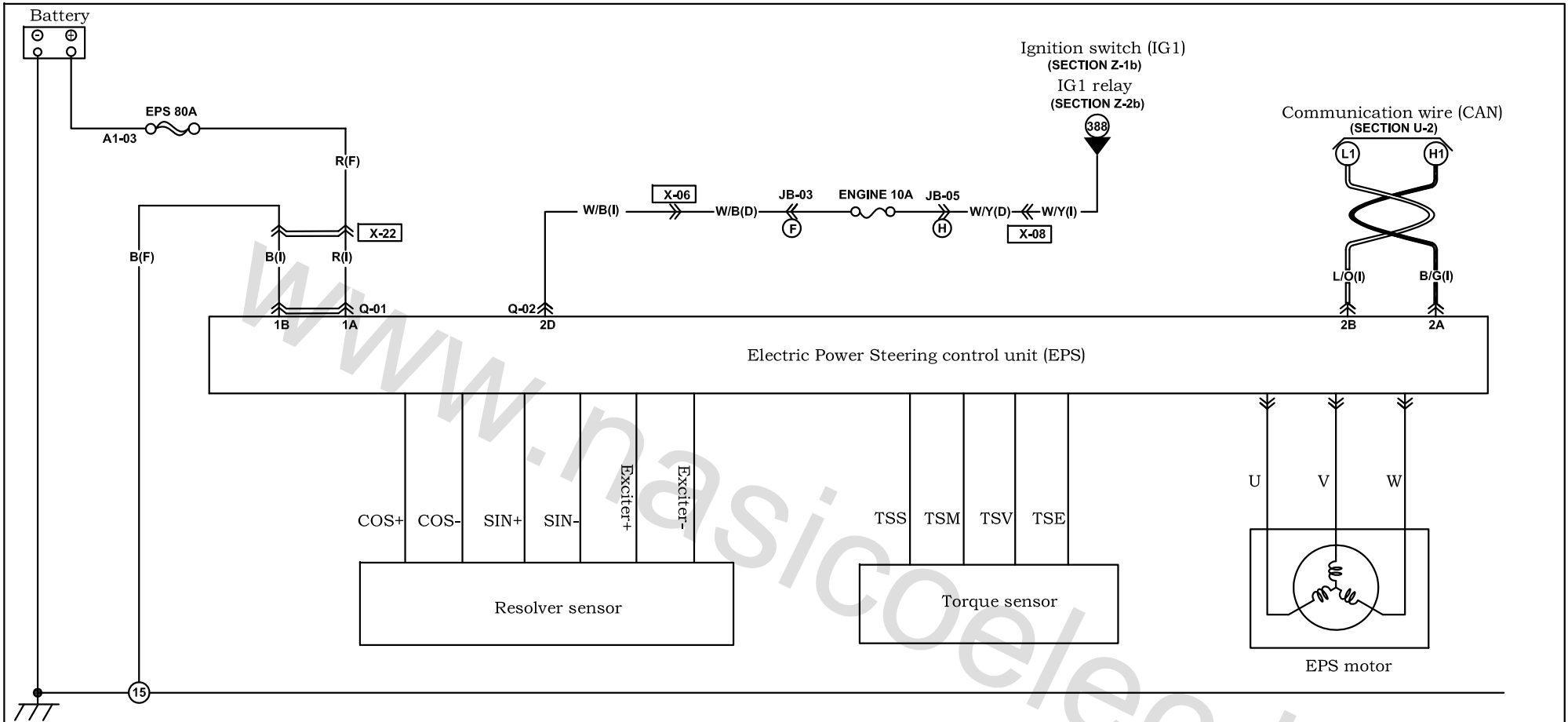

<p><b>Q-01</b> EPS power supply (I)</p>	<p><b>Q-02</b> EPS controller (I)</p>	<p><b>A1-03</b> Battery B+ (E)</p>				
---	---------------------------------------	------------------------------------	--	--	--	--

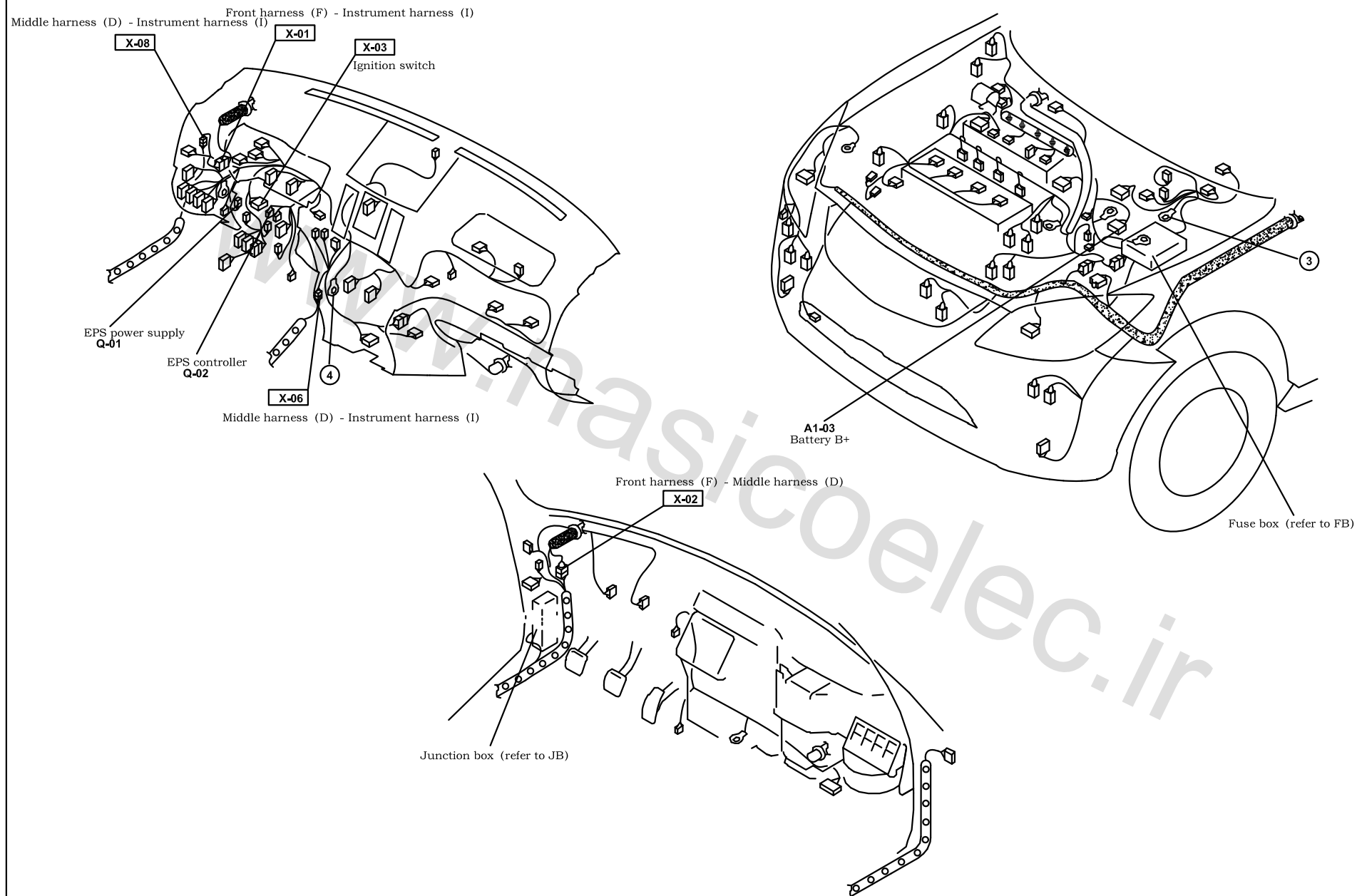

Harness mark:  (F)  (E)  (D)  (R)

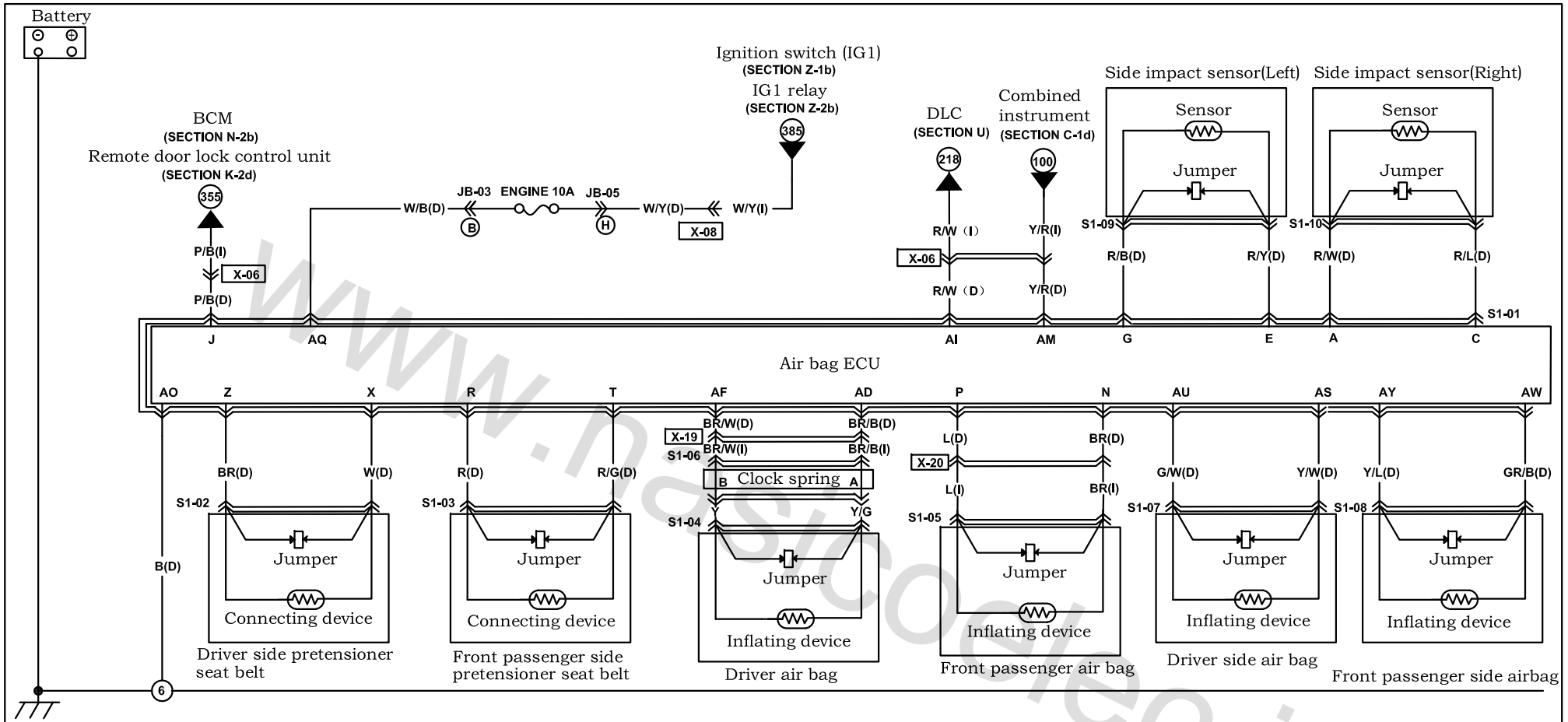

# Air bag/seat belt pretensioner system



S1-01 Air bag ECU (D)														() With side air bag							
AV																					
*	*	*	*	*	*	*	*	*	*	*	*	*	*	*	*	*	*				
{Y/L}	{GR/B}	{G/W}	{Y/W}	W/B	B	Y/R	*	R/W	BR/W	BR/B	*	BR	W	*	R/G	R	L				
AY																					
														S1-02 Driver side pretensioner seat belt (D)		S1-03 Front passenger pretensioner seat belt (D)		S1-04 Driver air bag(I)		S1-05 Front passenger air bag(I)	
														S1-07 Driver side air bag (D)		S1-08 Front passenger side air bag (D)		S1-09 Side impact sensor(Left)(D)		S1-10 Side impact sensor(Right)(D)	
														S1-06 Clock spring (I)							
														A		D					

Harness mark:  (F)  (E)  (D)  (R)

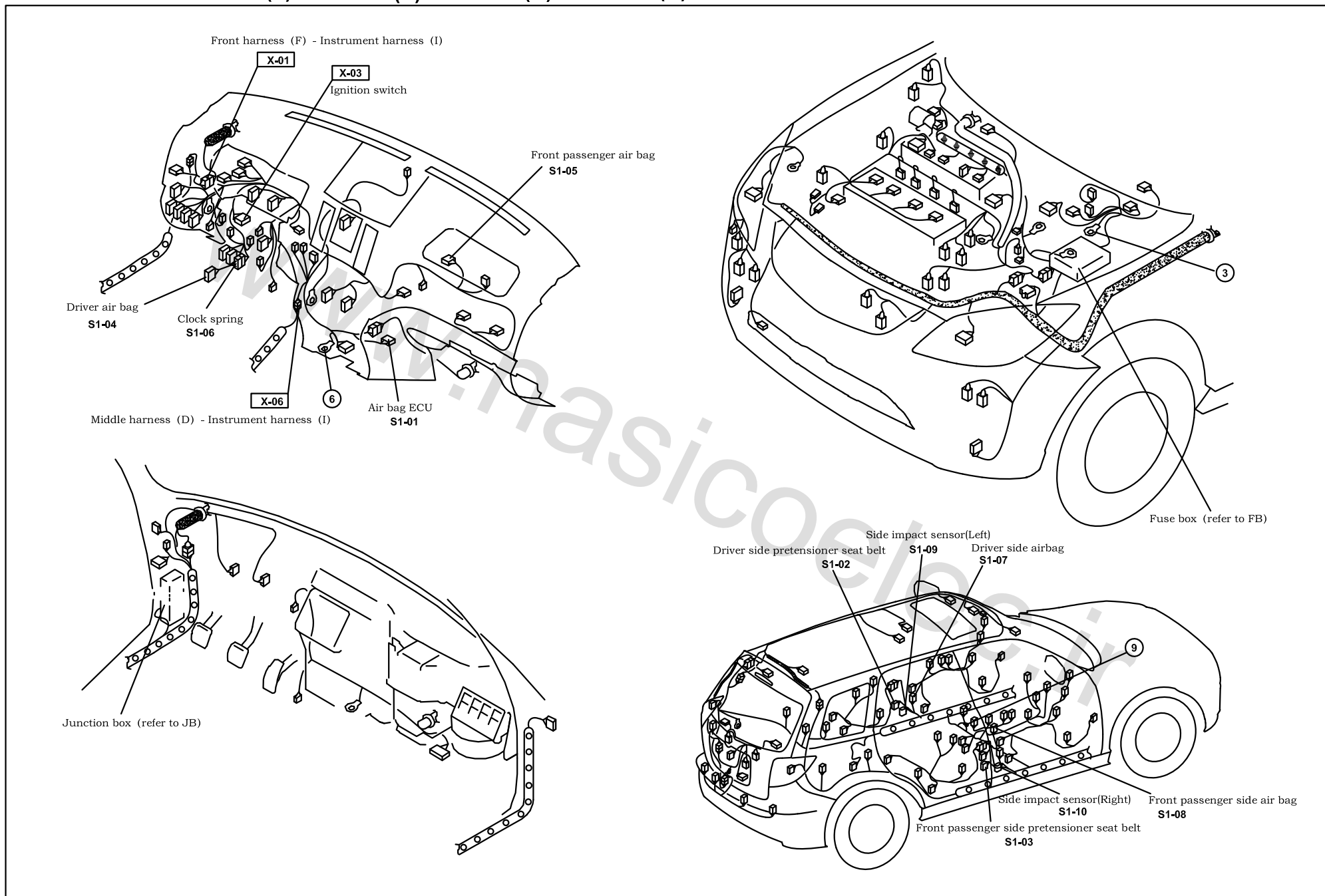

# Anti-theft system

T

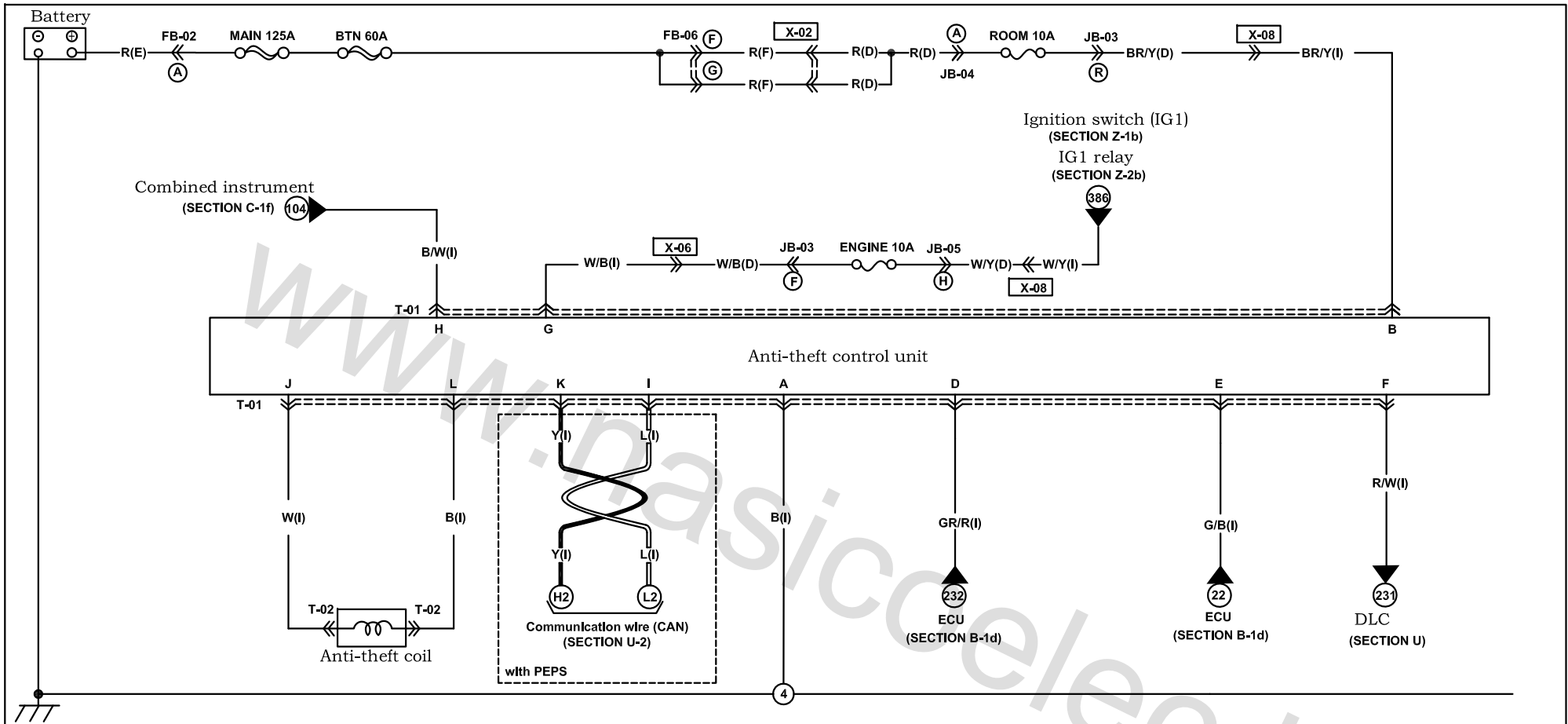

T-01 Anti-theft control unit (I)

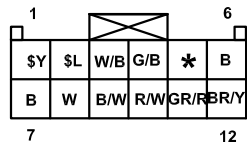

T-02 Anti-theft coil (I)

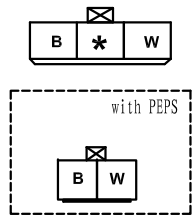

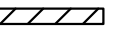

Harness mark:  (F)  (E)  (D)  (R)

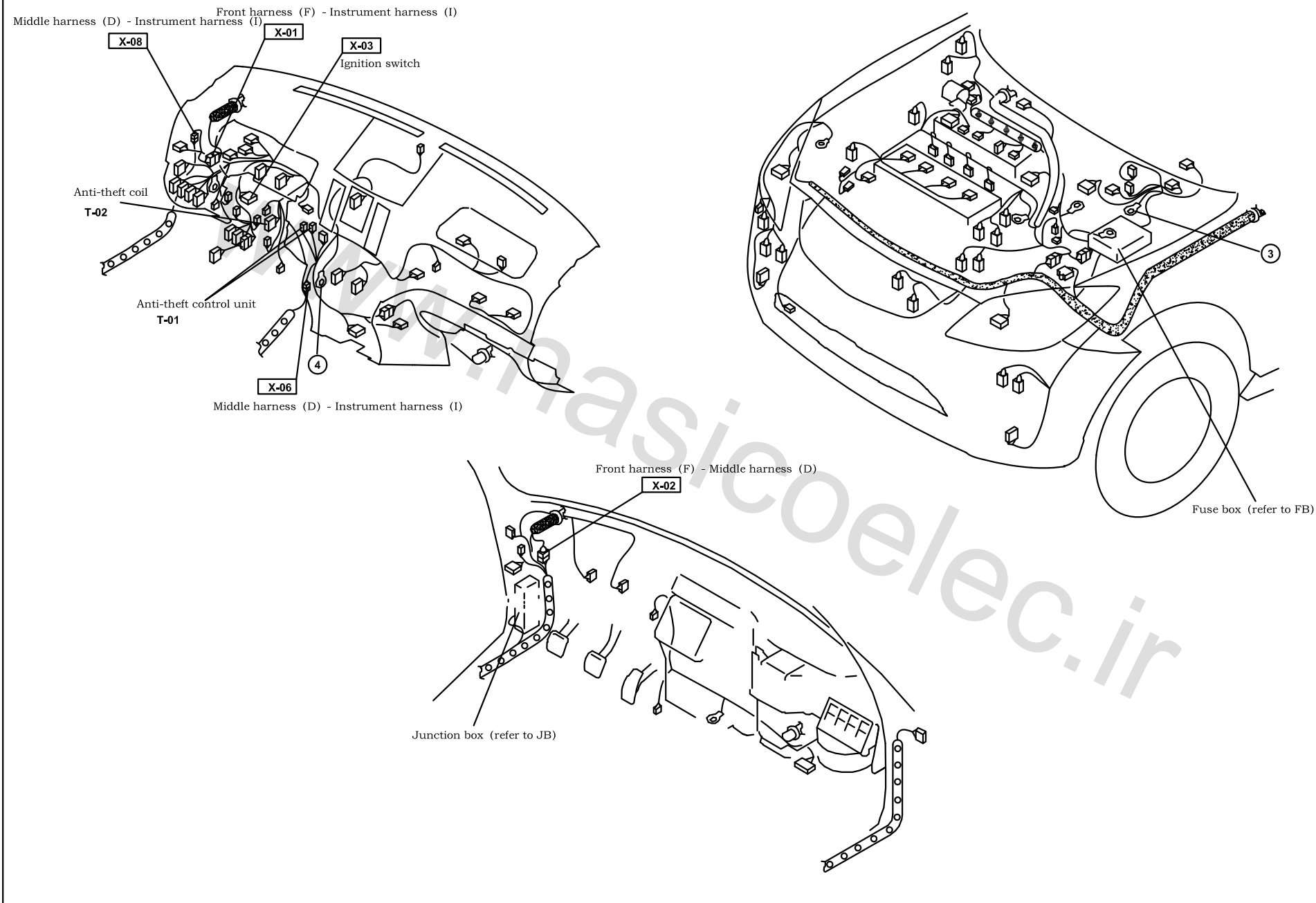

Diagnosis link connector (DLC)

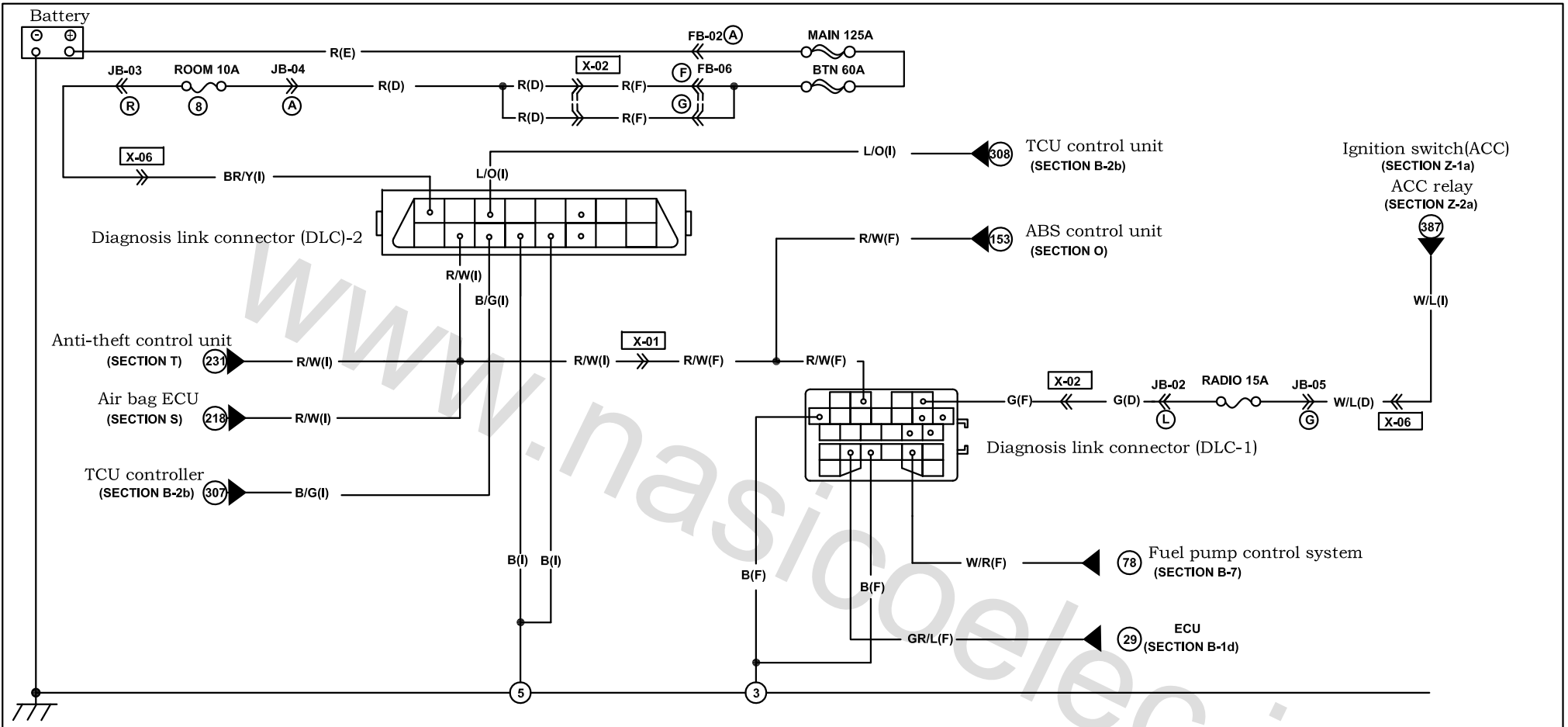

U-01 Diagnosis link connector (DLC)(EM)

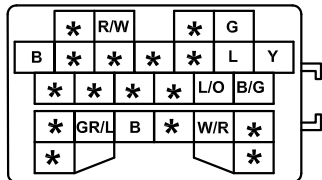

Note: view from the harness terminal

U-02 Diagnosis link connector (DLC)-2(I)

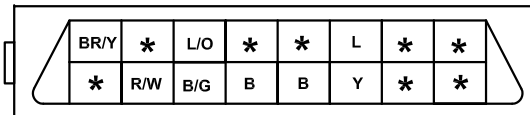

Note: view from the harness terminal

Harness mark:  (F)  (E)  (D)  (R)

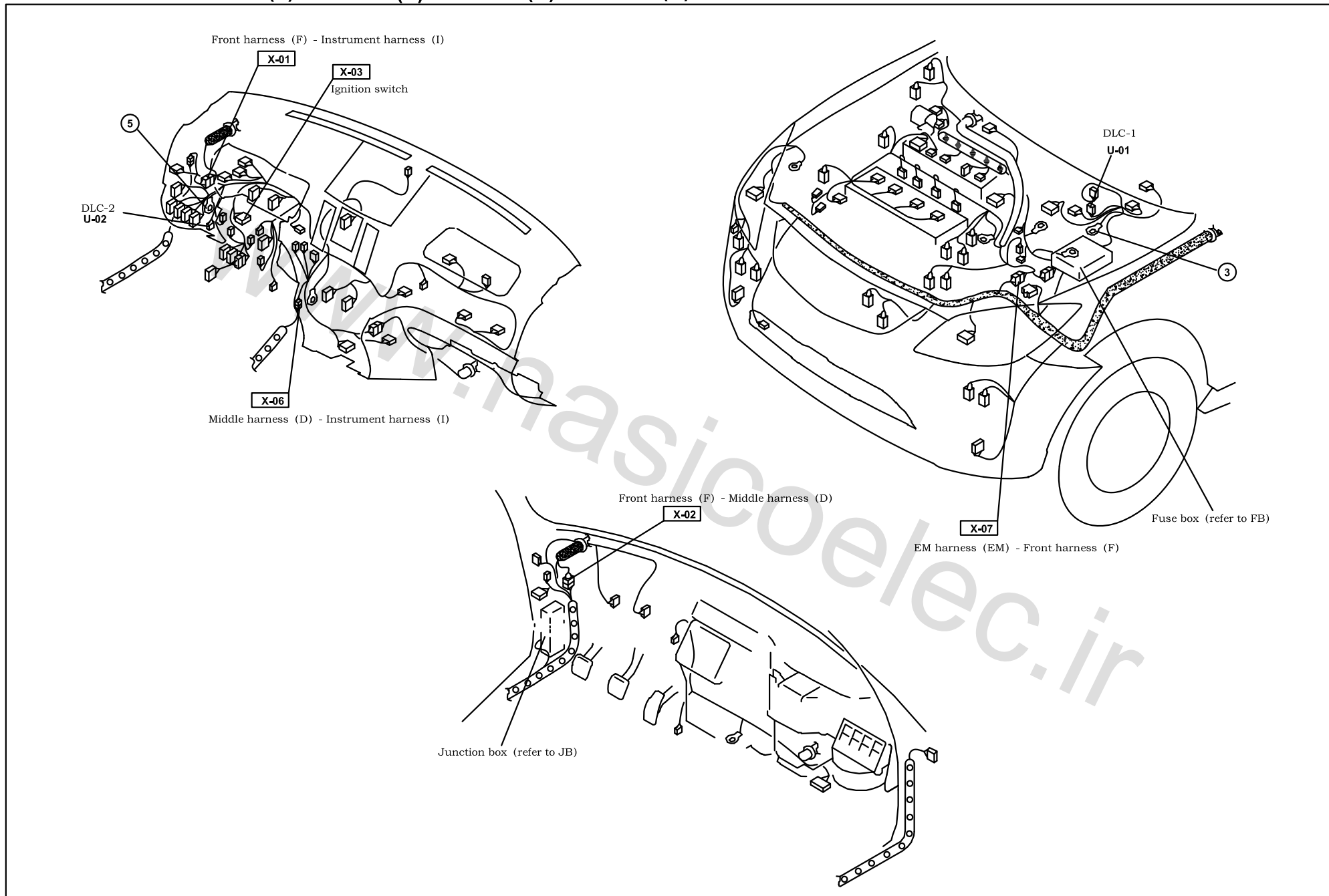

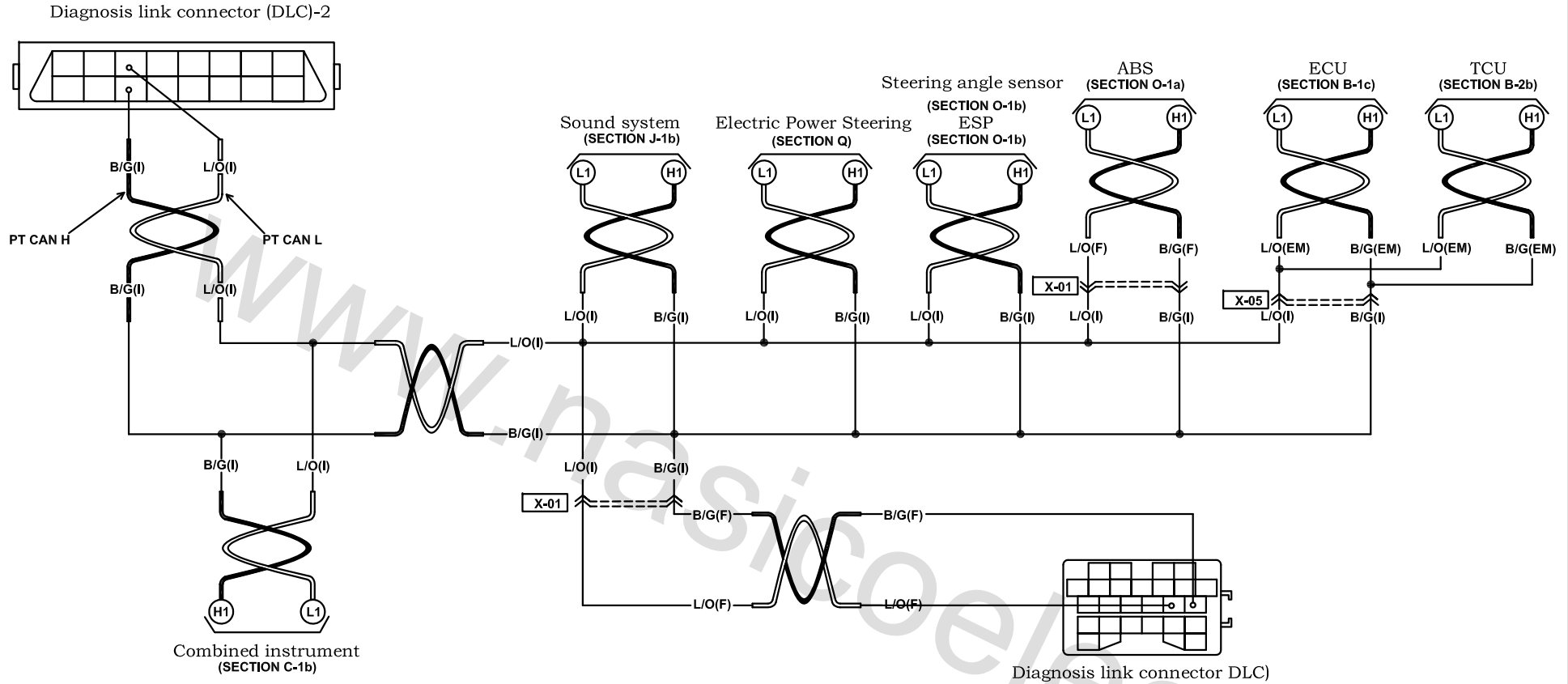

U-01 Diagnosis link connector (DLC)(EM)

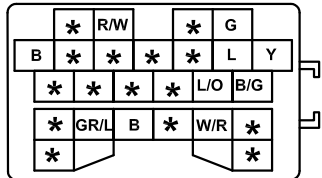

Note: view from the harness terminal

U-02 Diagnosis link connector (DLC)-2(I)

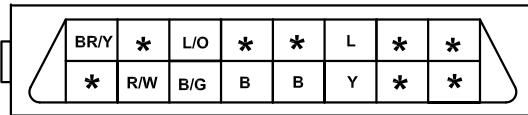

Note: view from the harness terminal

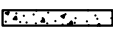
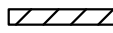
Harness mark:  (F)  (E)  (D)  (R)

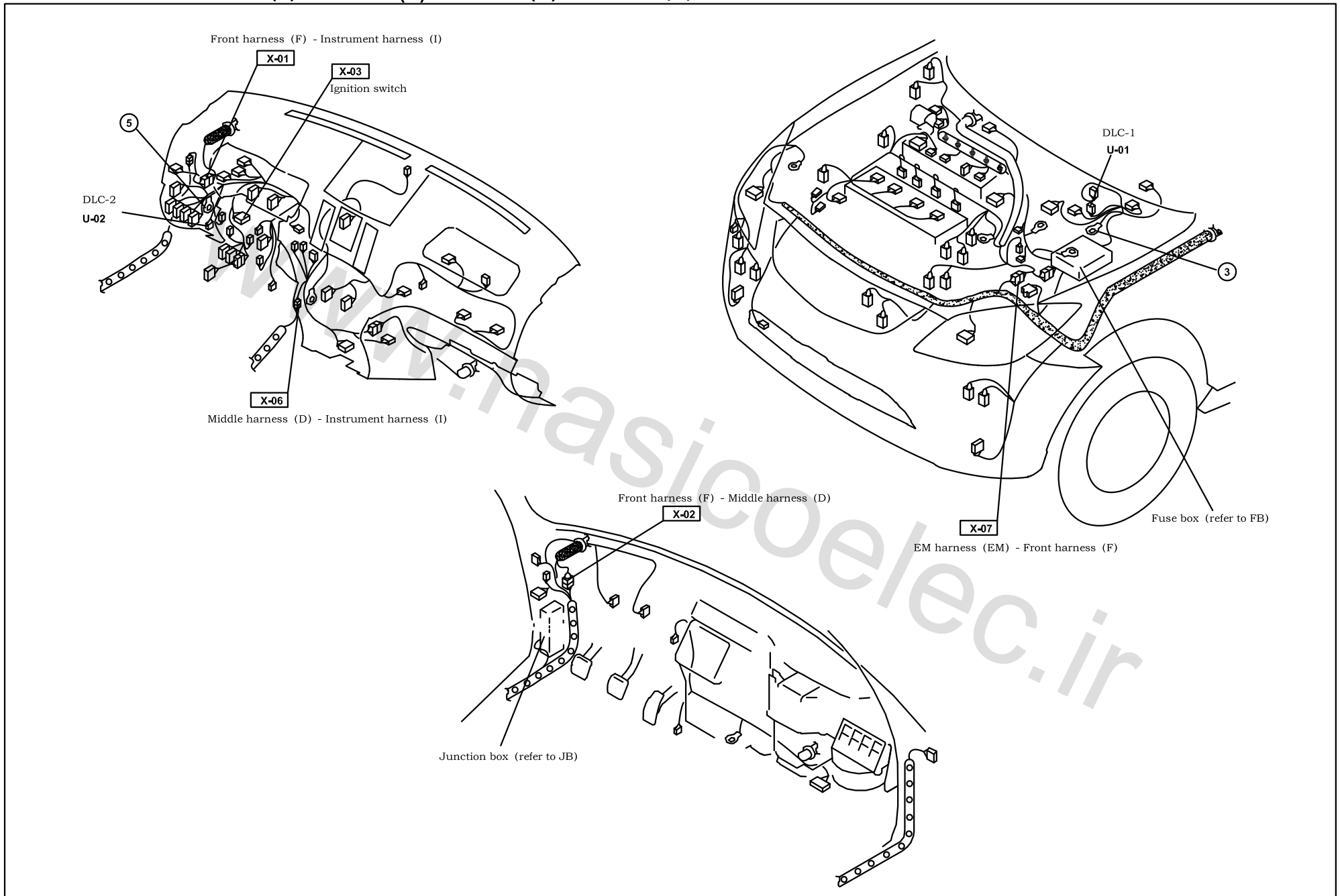

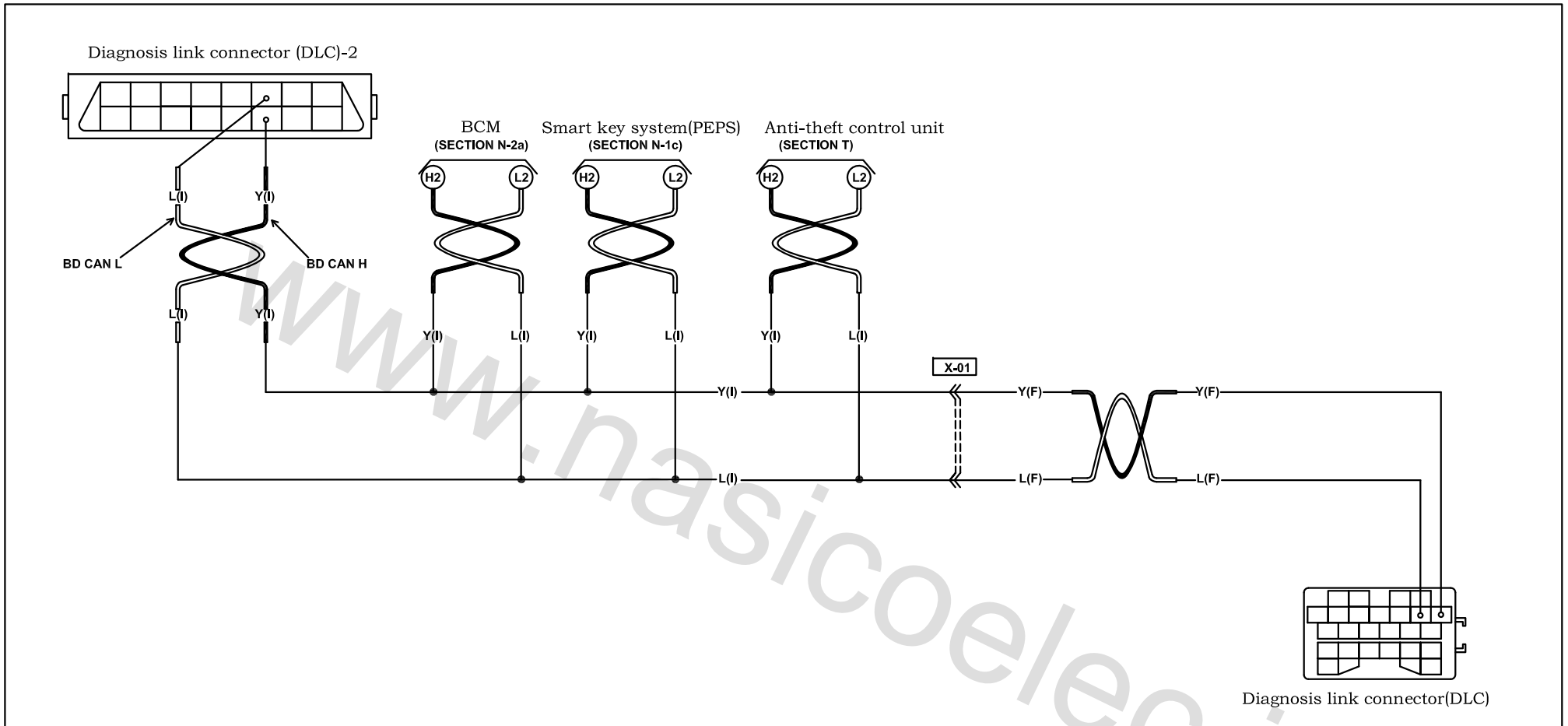

U-01 Diagnosis link connector (DLC)(EM)

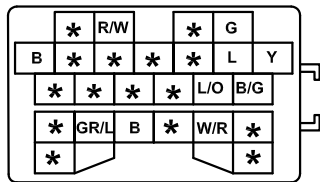

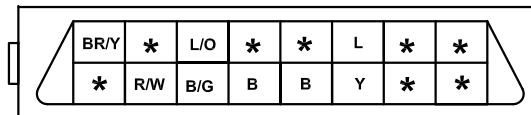

Note: view from the harness terminal

U-02 Diagnosis link connector (DLC)-2(I)



Note: view from the harness terminal

Harness mark:  (F)  (E)  (D)  (R)

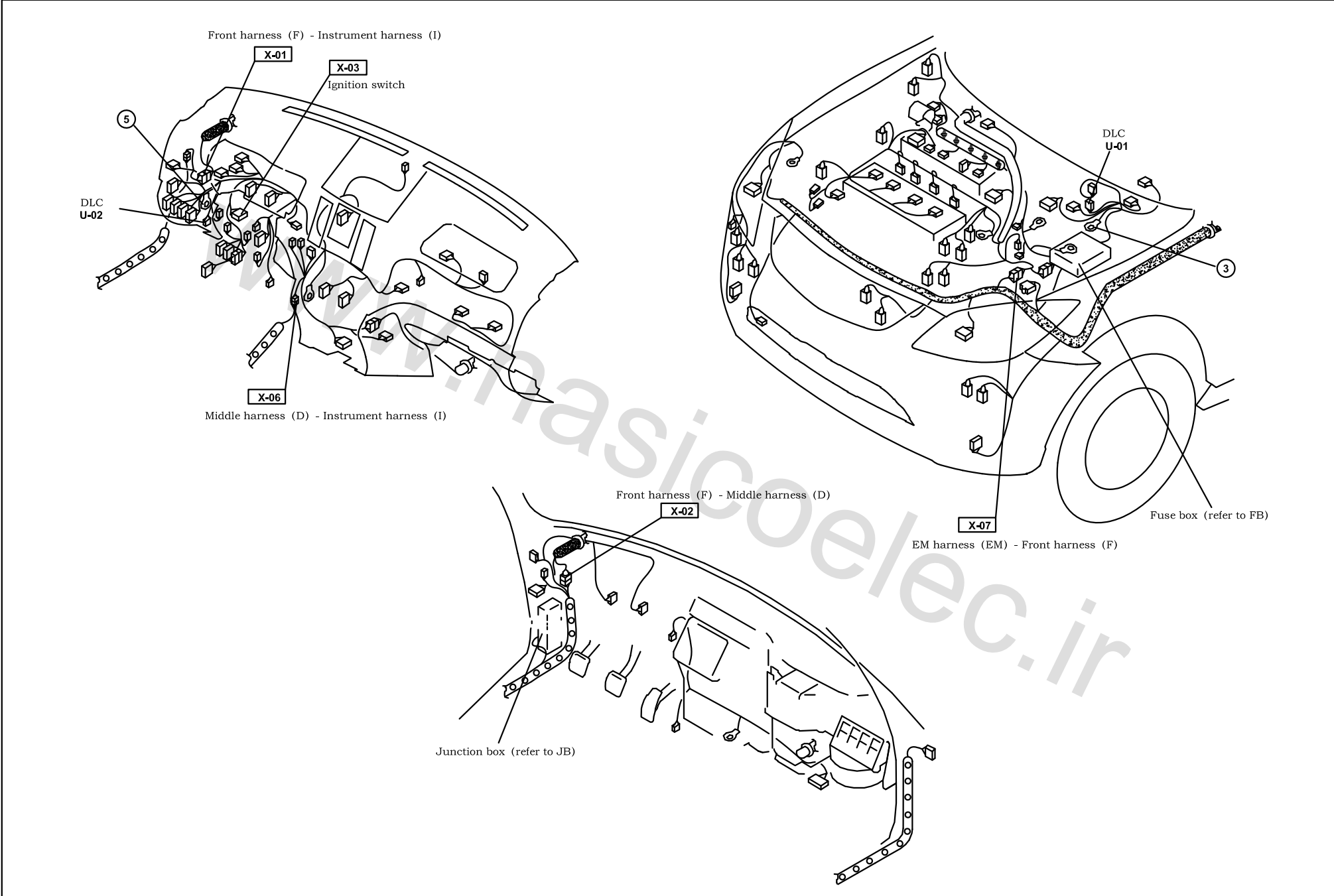

# Fuse box wiring diagram

FB

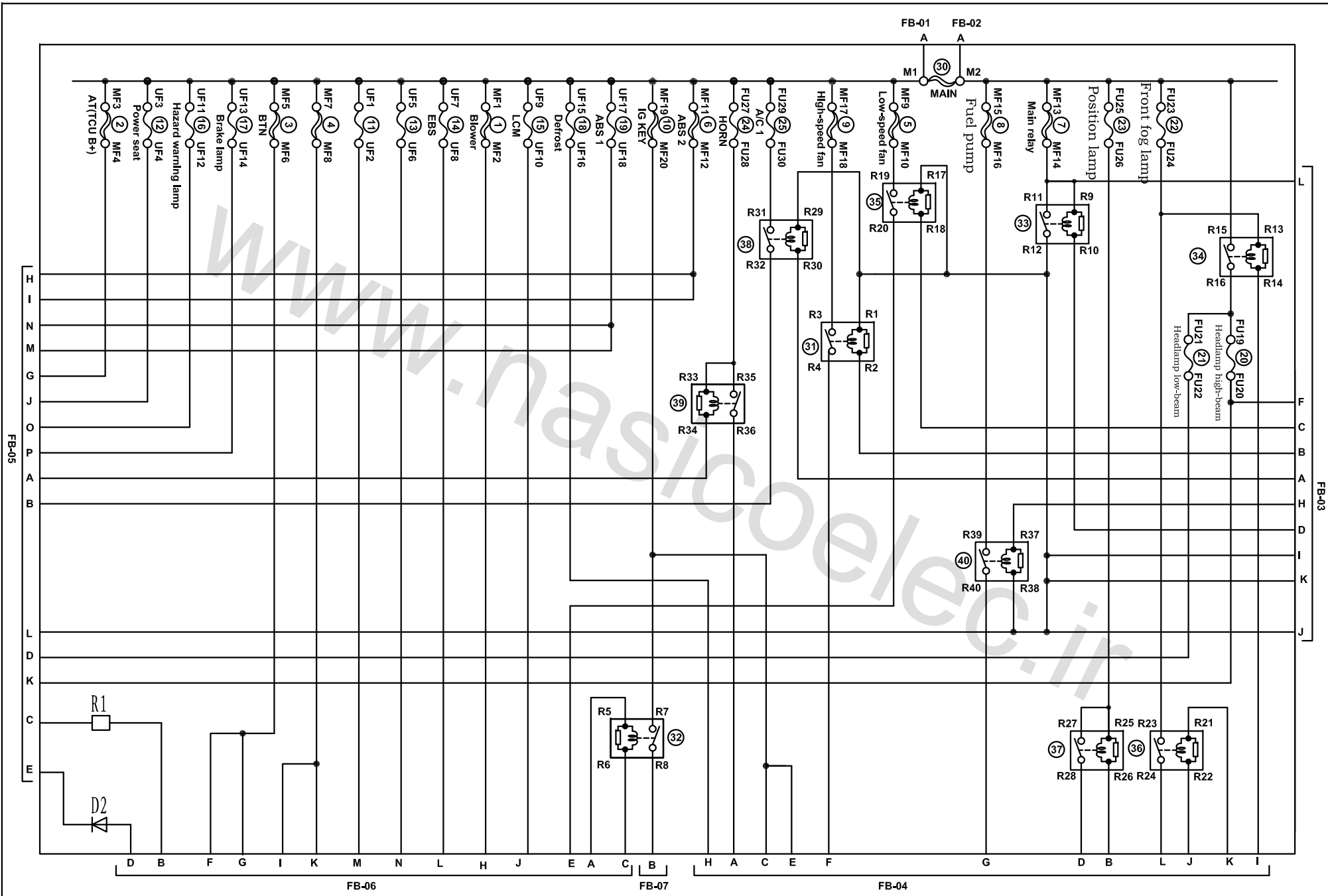



# Fuse box

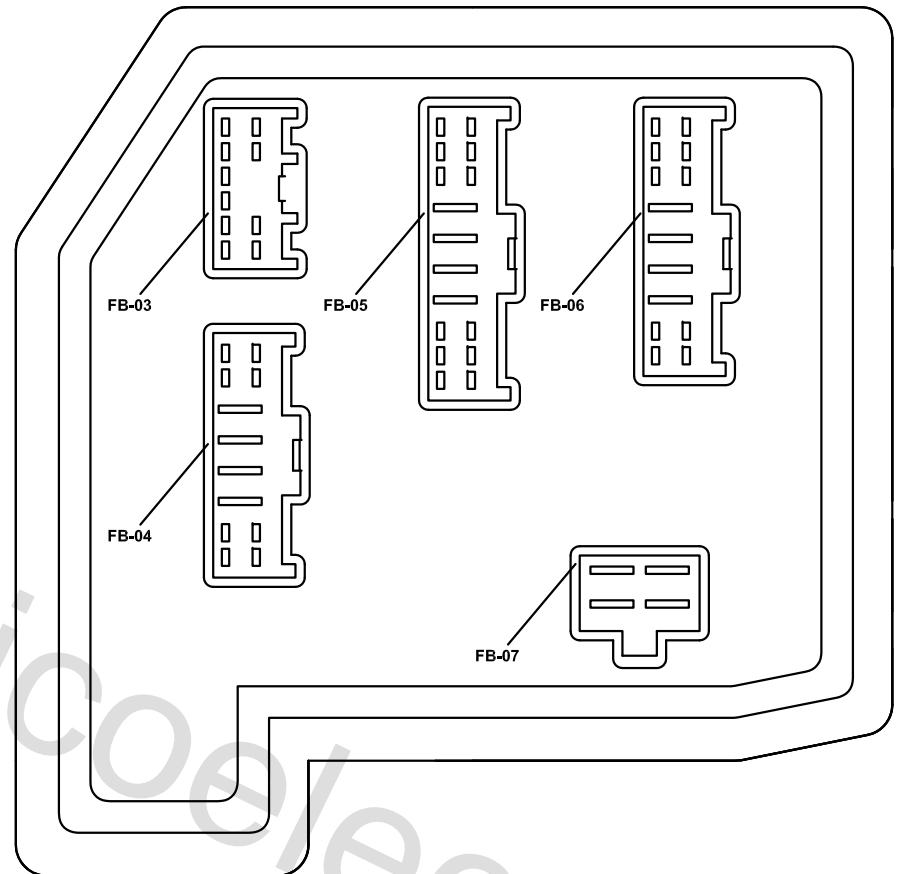
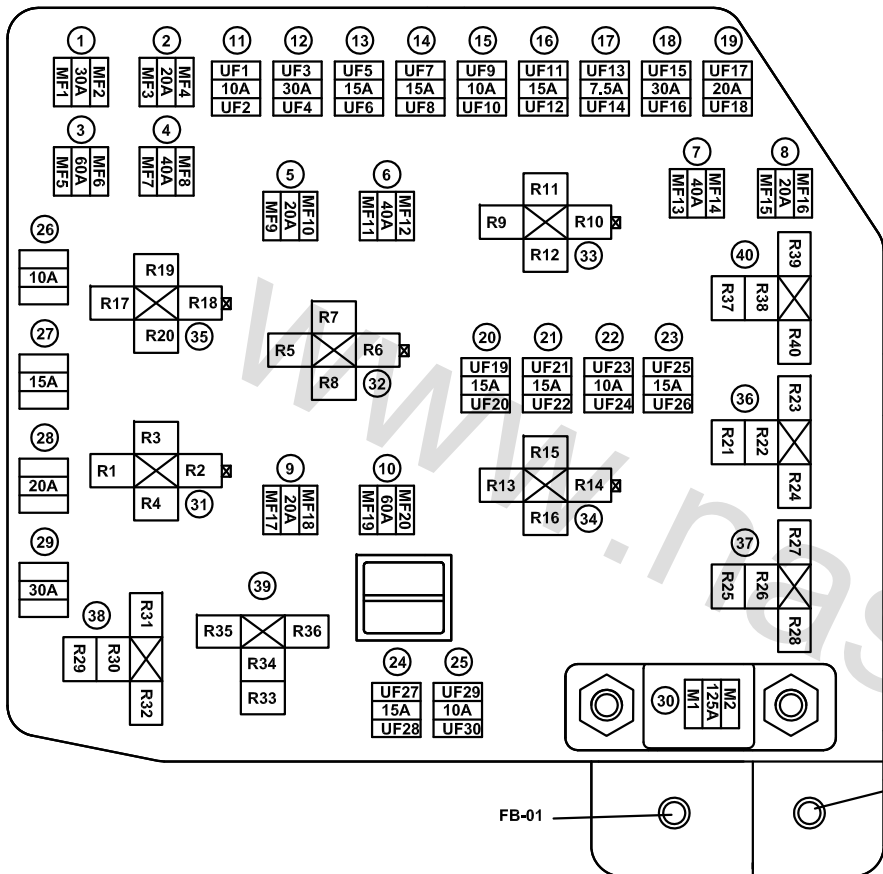

No.	Fuse name	No.	Fuse name	No.	Fuse name	No.	Relay name
①	Blower	⑪	PEPS 1	⑳	Headlamp low-beam	⑳	High-speed fan
②	AT(TCU B+)	⑫	Power seat (driver)	㉑	Headlamp high-beam	㉑	Start
③	BTN	⑬	PEPS 2	㉒	Front fog lamp	㉒	Main relay
④	*	⑭	EBS	㉓	Position lamp	㉓	Headlamp
⑤	Low-speed fan	⑮	LCM	㉔	HORN	㉔	Low-speed fan
⑥	ABS 2	⑯	Hazard warning lamp	㉕	A/C 1	㉕	Front fog lamp
⑦	Main relay	⑰	Brake lamp	㉖	*	㉖	Position lamp
⑧	Fuel pump	⑱	Defrosting	㉗	*	㉗	Compressor
⑨	High speed fan	㉑	ABS 1	㉘	*	㉘	Horn
⑩	IG KEY	㉒	Headlamp high-beam	㉙	Main fuse	㉙	Horn
		㉓		㉚		㉚	Horn
		㉔		㉛		㉛	Horn
		㉕		㉜		㉜	Horn
		㉖		㉝		㉝	Horn
		㉗		㉞		㉞	Horn
		㉘		㉟		㉟	Horn
		㉙		㊱		㊱	Horn
		㉚		㊲		㊲	Horn
		㉛		㊳		㊳	Horn
		㉜		㊴		㊴	Horn
		㉝		㊵		㊵	Horn
		㉞		㊶		㊶	Horn
		㉟		㊷		㊷	Horn
		㊱		㊸		㊸	Horn
		㊲		㊹		㊹	Horn
		㊳		㊺		㊺	Horn
		㊴		㊻		㊻	Horn
		㊵		㊼		㊼	Horn
		㊶		㊽		㊽	Horn
		㊷		㊾		㊾	Horn
		㊸		㊿		㊿	Horn
		㊹					
		㊺					
		㊻					
		㊼					
		㊽					
		㊾					
		㊿					

# Fuse box

**FB**

**FB-01** Engine harness (E)



**FB-02** Engine harness (E)



**FB-04** Front harness (F)

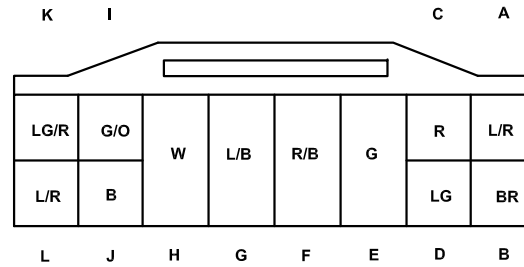

**FB-07** Engine harness (E)

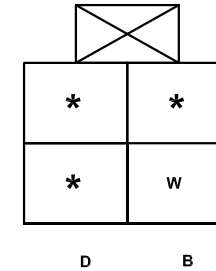

**FB-03** EM harness (EM)

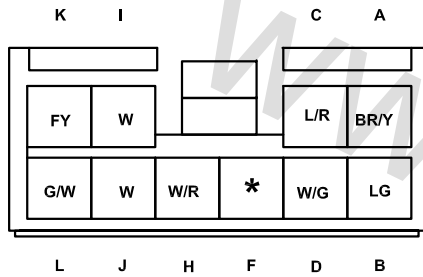

**FB-05** Front harness (F)

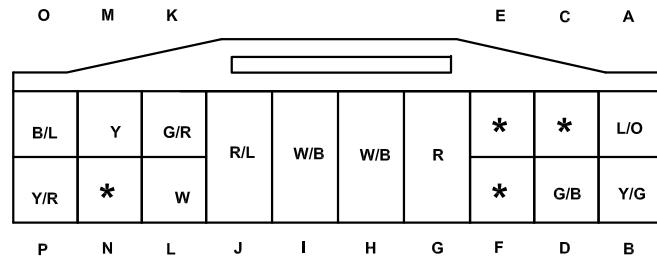

**FB-06** Front harness (F)

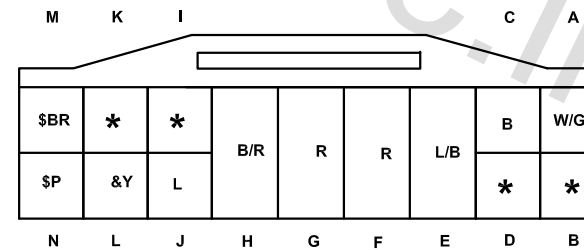

\$ with PEPS  
& with start-stop system

[www.nasicoelec.ir](http://www.nasicoelec.ir)

X-01 Front harness (F) - Instrument harness (I) \$ with PEPS

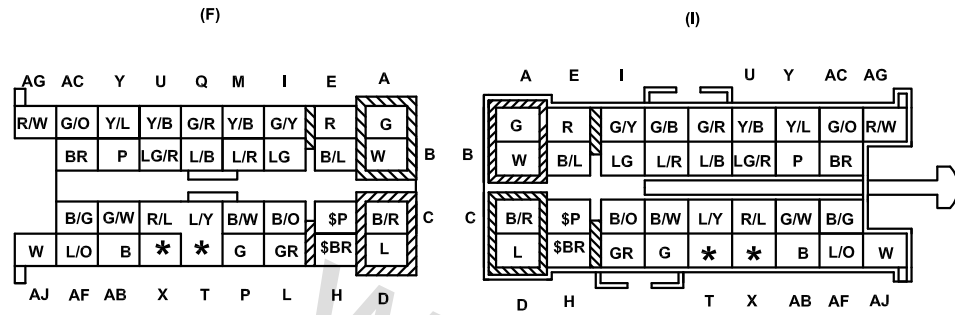

X-02 Front harness (F) - Middle harness (D) ( ) with ESP " " with power seat

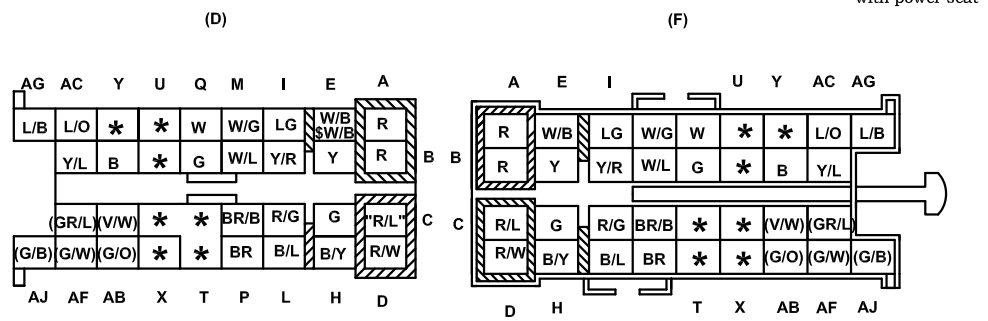

X-03 Ignition switch (I) & with start-stop

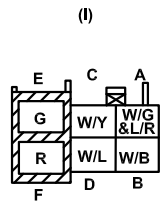

X-04 Engine harness (E) - EM harness (EM) & with start-stop

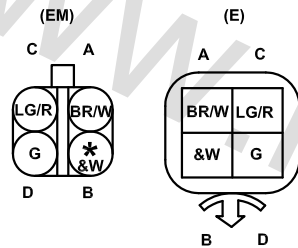

X-05 EM harness (EM) - Instrument harness (I)

( ) with ESP  
 < > with AT  
 \$ with PEPS  
 & with start-stop

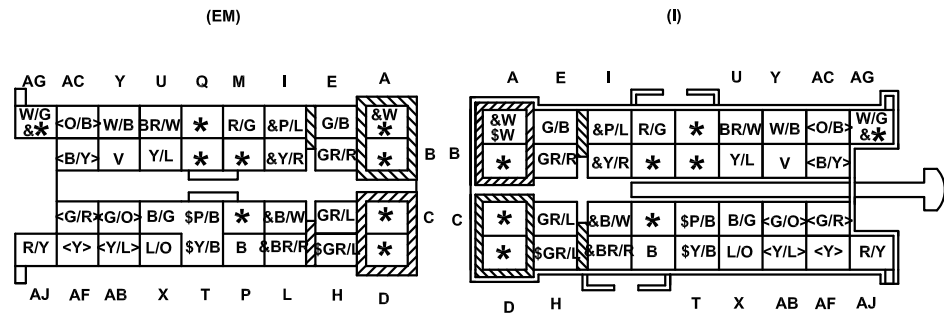

# Common connector list

**X-06** Instrument harness (I) -Middle harness (D)

\$ with PEPS

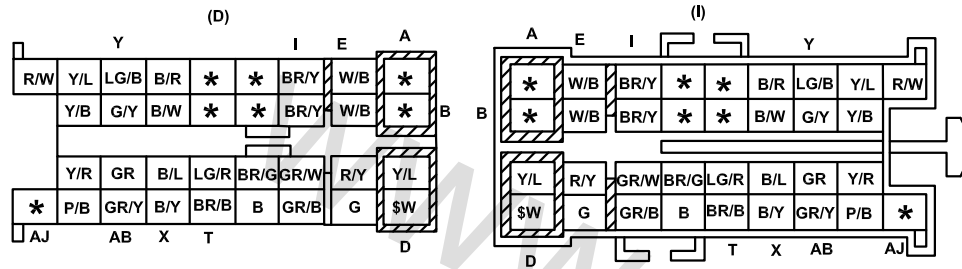

**X-08** Middle harness (D) -Instrument harness (I)

( ) with ESP  
\$ with PEPS

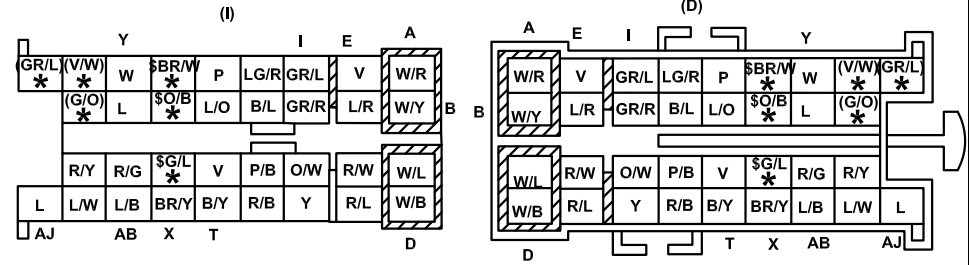

**X-07** EM harness (EM) - Front harness (F)

< > with AT

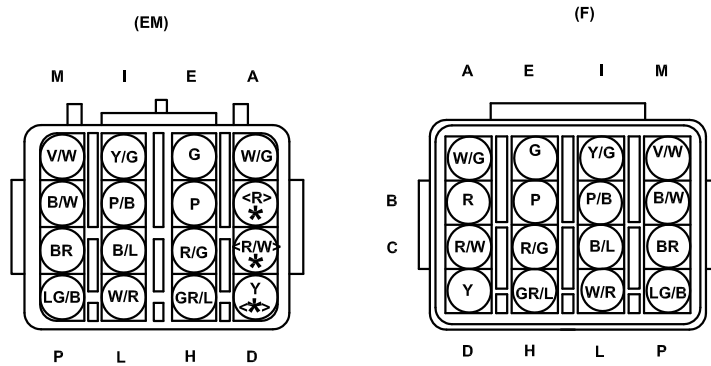

**X-09** 1# back door harness (R1#) - 2# back door harness (R2#)

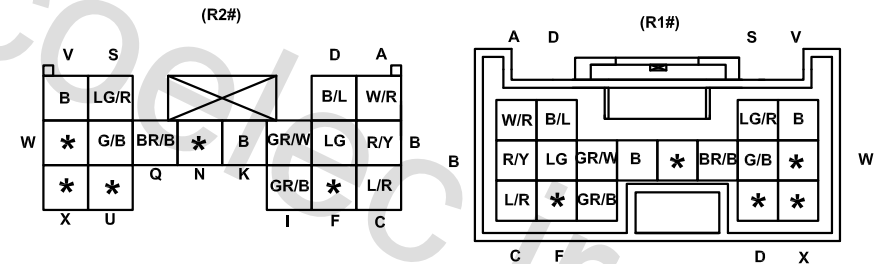

**X-10** Middle harness (D) - 2# back door harness (R2#)

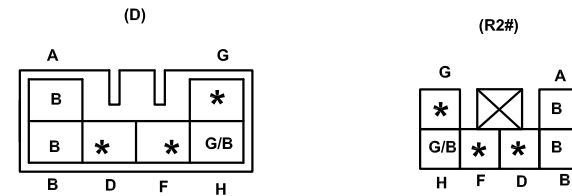

X-11 2# back door harness (R2#) - Middle harness (D)

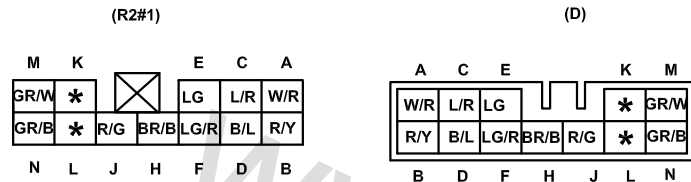

X-12 Middle harness (D) -Front door harness (DR1)

\$ with PEPS

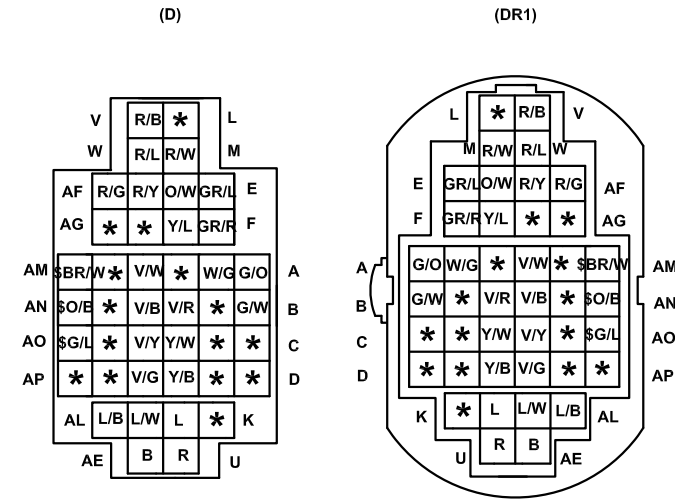

X-13 Middle harness (D) - Front door harness (DR2)

\$ with PEPS

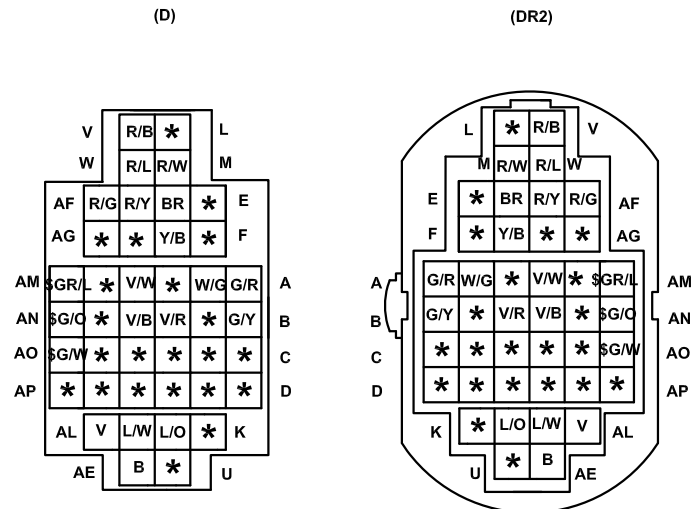

X-14 Middle harness (D) -Rear left door harness (DR3)

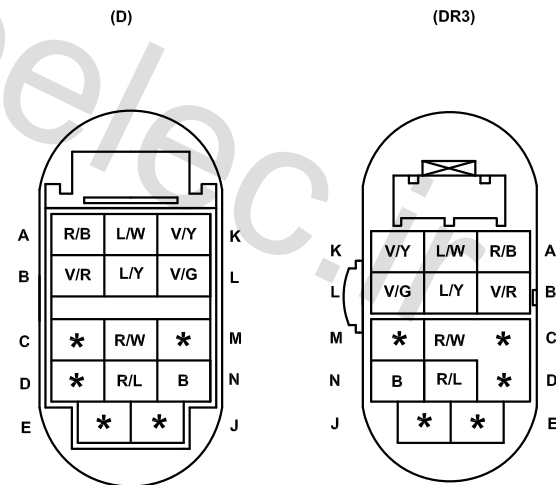

# Common connector list

**X-15** Middle harness (D) -Rear right door harness (DR4)

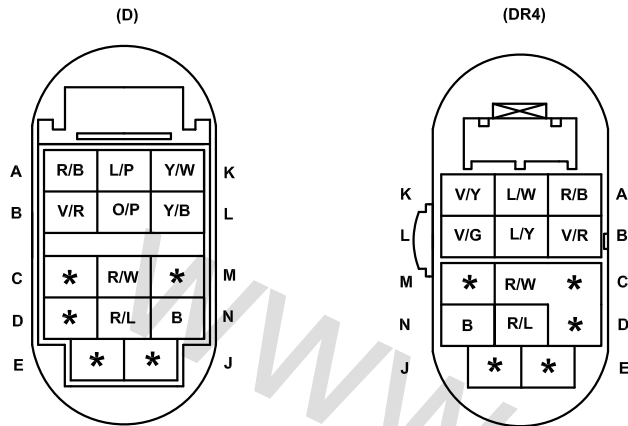

**X-16** Middle harness (D) - Reversing radar harness (RA)

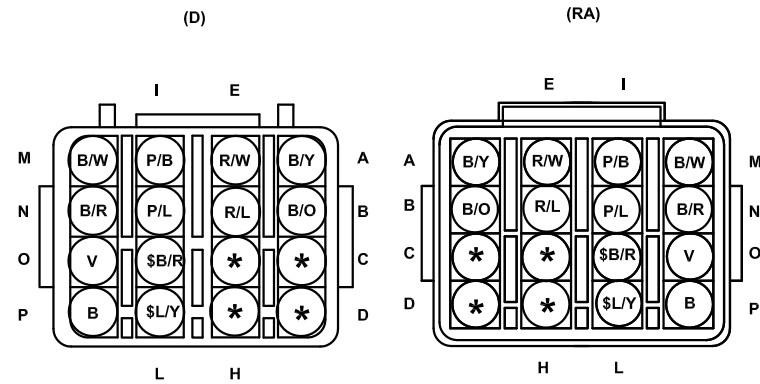

**X-17** Middle harness (D) -Interior harness (IN)

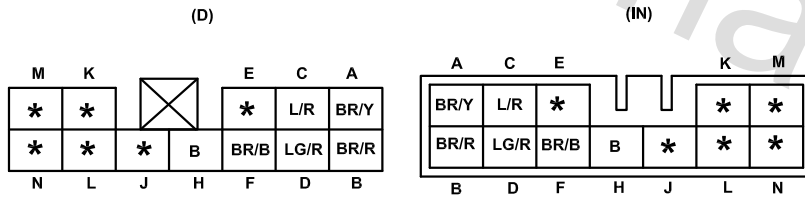

**X-19** Middle harness (D) -Instrument harness (I)



**X-20** Middle harness (D) -Instrument harness (I)

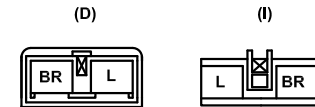

**X-21** Middle harness (D) -Instrument harness (I)

\$ with PEPS

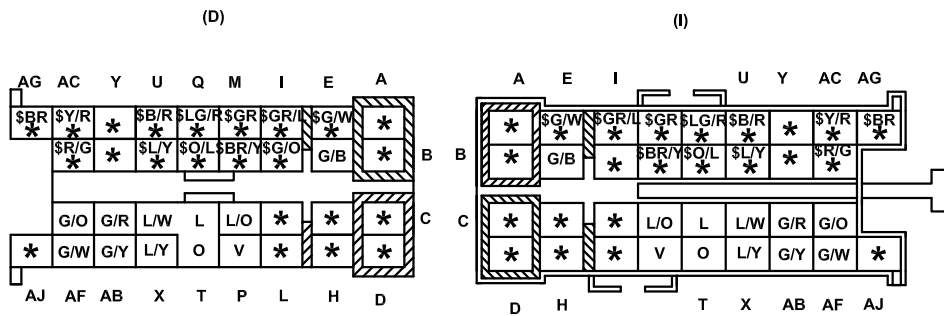

**X-22** Instrument harness (I) -Front harness (F)

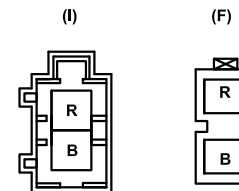

# Junction box wiring diagram

**JB**

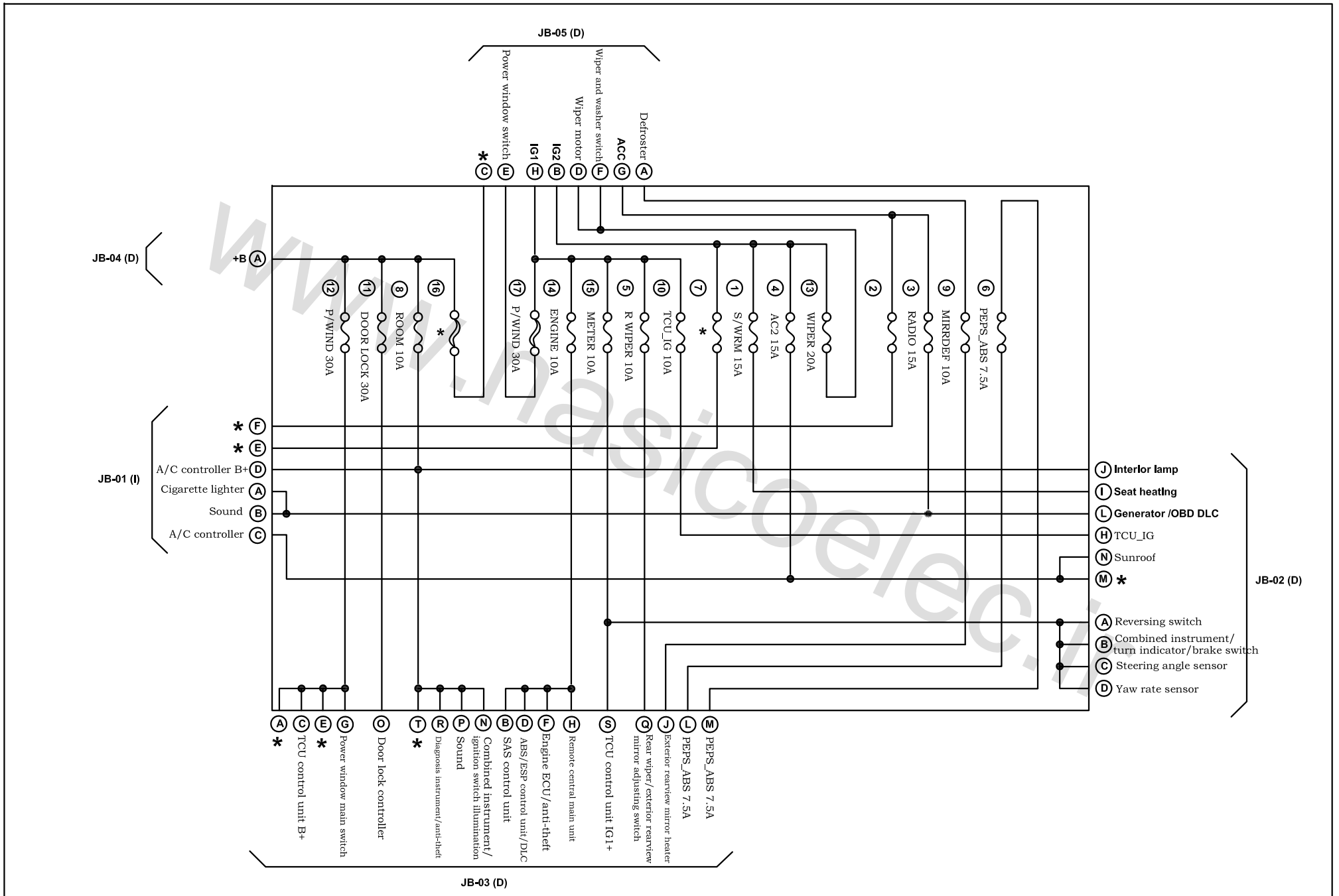



# Junction box

**JB-01** Instrument harness (I)

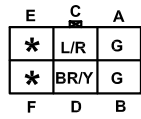

**JB-02** Middle harness (D) ( ) with ESP

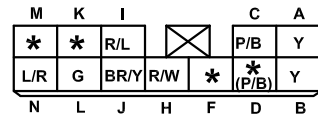

**JB-03** Middle harness (D)

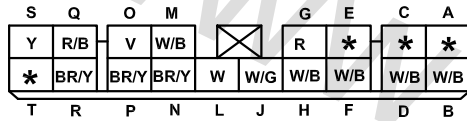

**JB-04** Middle harness (D)



**JB-05** Middle harness (D)

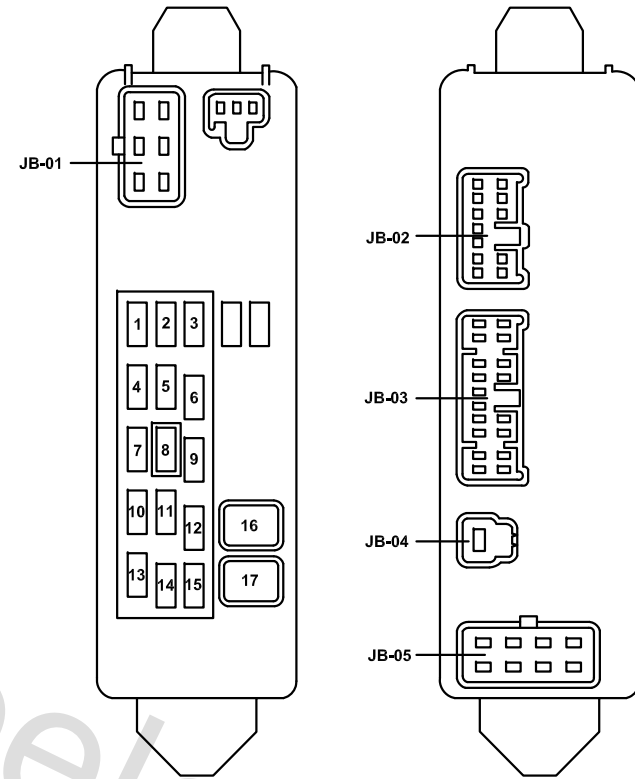
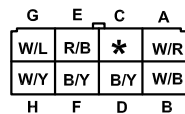

No.	Fuse name	Fuse	No.	Fuse name	Fuse
1	S/WRM	15A	10	TCU	10A
2	—	20A	11	DOOR LOCK	30A
3	RADIO	15A	12	P/WIND	30A
4	A/C 2	15A	13	WIPER	20A
5	R WIPER	10A	14	ENGINE	10A
6	PEPS_ABS	7.5A	15	METER	10A
7	—	—	16	—	—
8	ROOM	10A	17	P/WIND	30A
9	MIRRDEF	10A			