

## General Information

## SPECIFICATIONS

Description		Specifications		Limit
<b>General</b>				
Type		V-type, DOHC		
Number of cylinder		6		
Bore		86.7mm(3.4134in.)		
Stroke		75mm(2.9528in.)		
Total displacement		2,656cc		
Compression ratio		10.4		
Firing order		2-3-4-5-6-1		
<b>Valve timing</b>				
Intake valve	Opens (ATDC)	4° ~ -56°		
	Closes (ABDC)	60° ~ 0°		
Exhaust valve	Opens (BBDC)	46°		
	Closes (ATDC)	10°		
<b>Cylinder head</b>				
Flatness of gasket surface		0.03mm(0.0012in.) or less		0.05mm(0.0020in.)
Flatness of manifold mounting	Intake	0.15mm(0.0059in.) or less		
	Exhaust	0.15mm(0.0059in.) or less		
<b>Camshaft</b>				
Cam height	LH Camshaft	Intake	44.5mm(1.7520in.)	
		Exhaust	44.5mm(1.7520in.)	
	RH Camshaft	Intake	44.5mm(1.7520in.)	
		Exhaust	44.5mm(1.7520in.)	
Journal outer diameter	LH Camshaft	Intake	27.964 ~ 27.980mm(1.1009 ~ 1.1016in.)	
		Exhaust	27.964 ~ 27.980mm(1.1009 ~ 1.1016in.)	
	RH Camshaft	Intake	27.964 ~ 27.980mm(1.1009 ~ 1.1016in.)	
		Exhaust	27.964 ~ 27.980mm(1.1009 ~ 1.1016in.)	
Bearing oil clearance	Intake	0.020 ~ 0.057mm(0.0008 ~ 0.0022in.)		
	Exhaust	0.020 ~ 0.057mm(0.0008 ~ 0.0022in.)		
End play		0.05 ~ 0.15mm(0.0020 ~ 0.0059in.)		
<b>Valve</b>				
Valve length	Intake	110.1mm(4.3346in.)		
	Exhaust	111.1mm(4.3740in.)		

# General Information

# EM-3

Description		Specifications	Limit
Stem outer diameter	Intake	5.965 ~ 5.980mm(0.2348 ~ 0.2354in.)	
	Exhaust	5.950 ~ 5.965mm(0.2343 ~ 0.2348in.)	
Face angle		45° ~ 45.5°	
Thickness of valvehead(margin)	Intake	1.0mm(0.0394in.)	
	Exhaust	1.3mm(0.0512in.)	
Valve stem to valve guide clearance	Intake	0.020 ~ 0.050mm(0.0008 ~ 0.0020in.)	0.10mm(0.0039in.) or less
	Exhaust	0.035 ~ 0.065mm(0.0014 ~ 0.0026in.)	0.13mm(0.0051in.) or less
<b>Valve guide</b>			
Inner diameter	Intake	6.000 ~ 6.015mm(2.2362 ~ 2.2368in.)	
	Exhaust	6.000 ~ 6.015mm(2.2362 ~ 2.2368in.)	
Length	Intake	45.8 ~ 46.2mm(1.8031 ~ 1.8189in.)	
	Exhaust	46.8 ~ 47.2mm(1.8425 ~ 1.8583in.)	
<b>Valve spring</b>			
Free length		46.8mm(1.8425in.)	
Load	Height: 35mm	180.5 ~ 199.5N(18.4 ~ 20.3Kgf, 40.6 ~ 44.8lb)	
	Height: 26.5mm	342 ~ 378N(34.9 ~ 38.6Kgf, 76.9 ~ 85.1lb)	
Out of squareness		1.5° or less	
<b>MLA(Mechanical Lash Adjuster)</b>			
MLA outer diameter	Intake	29.964 ~ 29.980mm(1.1797 ~ 1.1803in.)	
	Exhaust	29.964 ~ 29.980mm(1.1797 ~ 1.1803in.)	
Cylinder head tappet bore inner diameter	Intake	30.000 ~ 30.025mm(1.1811 ~ 1.1821in.)	
	Exhaust	30.000 ~ 30.025mm(1.1811 ~ 1.1821in.)	
MLA to tappet bore clearance	Intake	0.020 ~ 0.061mm(0.0008 ~ 0.0024in.)	0.07mm(0.0027in.) or less
	Exhaust	0.020 ~ 0.061mm(0.0008 ~ 0.0024in.)	0.07mm(0.0027in.) or less
<b>Valve clearance (Engine coolant temperature 20°C [68°F])</b>			
Intake		0.17 ~ 0.23mm (0.0067 ~ 0.0090in.)	0.10 ~ 0.30mm (0.0039 ~ 0.0118in.)
Exhaust		0.27 ~ 0.33mm (0.0106 ~ 0.0129in.)	0.20 ~ 0.40mm (0.0078 ~ 0.0157in.)
<b>Cylinder block</b>			
Cylinder bore		96.00 ~ 96.03mm (3.7795 ~ 3.7807in.)	

Description		Specifications	Limit
Flatness of gasket surface		Less than 0.05mm (0.0019in.) [Less than 0.02mm (0.0008in.) / 150x150]	
<b>Piston</b>			
Piston outer diameter		95.96 ~ 95.99mm(3.7779 ~ 3.7791in.)	
Piston to cylinder clearance		0.03 ~ 0.05mm(0.0012 ~ 0.0020in.)	
Ring groove width	No. 1 ring groove	1.22 ~ 1.24mm (0.0480 ~ 0.0488in.)	
	No. 2 ring groove	1.22 ~ 1.24mm (0.0480 ~ 0.0488in.)	
	Oil ring groove	2.01 ~ 2.03mm (0.0791 ~ 0.0799in.)	
Piston O.S.		0.25mm(0.0098in.)	
<b>Piston ring</b>			
Side clearance	No. 1 ring	0.04 ~ 0.08mm(0.0016 ~ 0.0031in.)	0.1mm(0.0039in.)
	No. 2 ring	0.03 ~ 0.07mm(0.0012 ~ 0.0027in.)	0.1mm(0.0039in.)
	Oil ring	0.06 ~ 0.15mm(0.0024 ~ 0.0059in.)	0.2mm(0.0079in.)
End gap	No. 1 ring	0.15 ~ 0.30mm(0.0059 ~ 0.0118in.)	0.6mm(0.0236in.)
	No. 2 ring	0.30 ~ 0.45mm(0.0118 ~ 0.0177in.)	0.7mm(0.0275in.)
	Oil ring	0.20 ~ 0.70mm(0.0078 ~ 0.0275in.)	0.8mm(0.0315in.)
Piston ring O.S.		0.25mm(0.0098in.)	
<b>Piston pin</b>			
Piston pin outer diameter		21.001 ~ 21.007mm(0.8268 ~ 0.8270in.)	
Piston pin hole inner diameter		21.014 ~ 21.023mm(0.8273 ~ 0.8277in.)	
Piston pin hole clearance		0.007 ~ 0.022mm(0.0003 ~ 0.0009in.)	
Connecting rod small end inner diameter		20.974 ~ 20.985mm(0.8257 ~ 0.8262in.)	
Connecting rod small end hole clearance		0.016 ~ 0.033mm(0.0006 ~ 0.0013in.)	
<b>Connecting rod</b>			
Connecting rod big end inner diameter		51.000 ~ 51.018mm(2.0079 ~ 2.0086in.)	
Connecting rod bearing oil clearance		0.018 ~ 0.036mm(0.0007 ~ 0.0014in.)	
Side clearance		0.1 ~ 0.25mm (0.0039 ~ 0.0098in.)	0.4mm(0.0157in.)
<b>Crankshaft</b>			
Main journal outer diameter		61.982 ~ 62.000mm(2.4402 ~ 2.4409in.)	
Pin journal outer diameter		47.982 ~ 48.000mm(1.8891 ~ 1.8898in.)	

# General Information

# EM-5

Description		Specifications	Limit
Main bearing oil clearance		0.004 ~ 0.022mm(0.0002 ~ 0.0009in.)	
End play		0.07 ~ 0.25mm(0.0028 ~ 0.0098in.)	0.30mm(0.0118in.)
<b>Oil pump</b>			
Relief valve opening pressure		490.33 ~ 588.40kPa(5.0 ~ 6.0kgf/cm <sup>2</sup> , 71.12 ~ 85.34 psi)	
<b>Engine oil</b>			
Oil quantity (Total)		4.8 L (5.07 US qt, 4.22 Imp qt)	
Oil quantity (Oil pan)		4.2 L (4.43 US qt, 3.69 Imp qt)	
Oil quantity (Drain and refill including oil filter)		4.5 L (4.75 US qt, 3.95 Imp qt)	
Oil quality		ABOVE API SJ / SL or SAE 5W-20	
Oil pressure		130kPa(1.32kgf/cm <sup>2</sup> , 18.77psi) [at 1000rpm, 110°C(230°F)]	
<b>Cooling system</b>			
Cooling method		Forced circulation with electrical fan	
Coolant quantity		8.2~8.3L(8.66~8.77U.S.qts, 7.22~7.30Imp.qts)	
Thermostat	Type	Wax pellet type	
	Opening temperature	82±2°C (179.6±35.6°F)	
	Fully opened temperature	95°C (203°F)	
	Full lift	10mm (0.3937in.) or more	
Radiator cap	Main valve opening pressure	93.16 ~ 122.58kpa(0.95 ~ 1.25 kg/cm <sup>2</sup> , 13.51 ~ 17.78psi)	
	Vacuum valve opening pressure	0.98 ~ 4.90 kpa(0.01 ~ 0.05 kg/cm <sup>2</sup> , 0.14 ~ 0.71 psi)	
<b>Engine coolant temperature sensor</b>			
Type		Thermister type	
Resistance	20°C (68°F)	2.31 ~ 2.59 kΩ	
	80°C(176°F)	0.3222 kΩ	

## TIGHTENING TORQUE

Item	Quantity	Nm	kgf.m	lb-ft
Oil seal case bolt	3	9.8 ~ 11.8	1.0 ~ 1.2	7.2 ~ 8.7
Main bearing cap bolt(M10)	8	(26.5~32.4) + (90~95°)	(2.7~3.3) + (90~95°)	(19.5~23.9) + (90~95°)
Main bearing cap bolt(M8)	8	(12.7~18.6) + (90~95°)	(1.3~1.9) + (90~95°)	(9.4~13.7) + (90~95°)
Rear plate bolt	1	9.8 ~ 11.8	1.0 ~ 1.2	7.2 ~ 8.7
Oil pump case bolt(8×25)	1	18.6 ~ 23.5	1.9 ~ 2.4	13.7 ~ 17.4
Oil pump case bolt(8×35)	1	18.6 ~ 23.5	1.9 ~ 2.4	13.7 ~ 17.4
TimingOil pump case bolt(8×65)	1	18.6 ~ 23.5	1.9 ~ 2.4	13.7 ~ 17.4
TimiOil relief plug	1	39.2 ~ 49.0	4.0 ~ 5.0	28.9 ~ 36.2
Oil filter bracket bolt(8×35)	4	18.6 ~ 23.5	1.9 ~ 2.4	13.7 ~ 17.4
Oil filter bracket bolt(8×65)	2	18.6 ~ 23.5	1.9 ~ 2.4	13.7 ~ 17.4
Oil filter insert	1	44.1 ~ 53.9	4.5 ~ 5.5	32.5 ~ 39.8
Timing chain cover bolt	21	9.8 ~ 11.8	1.0 ~ 1.2	7.2 ~ 8.7
Upper oil pan bolt(8×22)	15	18.6 ~ 23.5	1.9 ~ 2.4	13.7 ~ 17.4
Upper oil pan bolt(163.5mm)	1	4.9 ~ 6.9	0.5 ~ 0.7	3.6 ~ 5.1
Upper oil pan bolt(154.5mm)	1	4.9 ~ 6.9	0.5 ~ 0.7	3.6 ~ 5.1
Lower oil pan bolt	11	9.8 ~ 11.8	1.0 ~ 1.2	7.2 ~ 8.7
Oil drain plug	1	34.3 ~ 44.1	3.5 ~ 4.5	25.3 ~ 32.5
Engine support bracket bolt(10×94)	2	58.8 ~ 68.6	6.0 ~ 7.0	43.4 ~ 50.6
Engine support bracket bolt(10×102.5)	1	58.8 ~ 68.6	6.0 ~ 7.0	43.4 ~ 50.6
Camshaft bearing cap bolt(6×38)	24	10.8 ~ 12.7	1.1 ~ 1.3	8.0 ~ 9.4
Camshaft bearing cap bolt(8×38)	12	20.6 ~ 25.5	2.1 ~ 2.6	15.2 ~ 18.8
Cylinder head bolt	16	(22.6~26.5) + (58~62°) + (43~47°)	(2.3~2.7) + (58~62°) + (43~47°)	(16.6~19.5) + (58~62°) + (43~47°)
Cylinder head cover bolt	22	7.8 ~ 9.8	0.8 ~ 1.0	5.8 ~ 7.2
Crankshaft pulley bolt	1	166.7 ~ 176.5	17.0 ~ 18.0	123.0 ~ 130.2
Drive plate bolt	8	71.6 ~ 75.5	7.3 ~ 7.7	52.8 ~ 55.7
Connecting rod bearing cap bolt	12	(17.7~21.6) + (90~94°)	(1.8~2.2) + (90~94°)	(13.0~15.9) + (90~94°)
OCV(Oil Control Valve) bolt	2	7.8 ~ 9.8	0.8 ~ 1.0	5.8 ~ 7.2
CVVT & exhaust cam sprocket bolt	4	66.7 ~ 78.5	6.8 ~ 8.0	49.2 ~ 57.9
Timing chain auto tensioner bolt	4	10.8 ~ 12.7	1.1 ~ 1.3	8.0 ~ 9.4
Camshaft sprocket bolt	2	88.3 ~ 107.9	9.0 ~ 11.0	65.1 ~ 79.6
Timing belt idler bolt	1	49.0 ~ 58.8	5.0 ~ 6.0	36.2 ~ 43.4

# General Information

# EM-7

Item	Quantity	Nm	kgf.m	lb-ft
Timing belt tensioner bolt	2	19.6 ~ 26.5	2.0 ~ 2.7	14.5 ~ 19.5
Timing belt tensioner arm bolt	1	34.3 ~ 53.9	3.5 ~ 5.5	25.3 ~ 39.8
Water pump bolt(8×20)	3	14.7 ~ 21.6	1.5 ~ 2.2	10.8 ~ 15.9
Water pump bolt(8×25)	4	14.7 ~ 21.6	1.5 ~ 2.2	10.8 ~ 15.9
Drive belt idler bolt	1	34.3 ~ 53.9	3.5 ~ 5.5	25.3 ~ 39.8
Drive belt tensioner bolt	1	34.3 ~ 53.9	3.5 ~ 5.5	25.3 ~ 39.8
Water pipe bolt	1	16.7 ~ 19.6	1.7 ~ 2.0	12.3 ~ 14.5
Water temp. control assembly nut	4	29.4 ~ 41.2	3.0 ~ 4.2	21.7 ~ 30.4
Oil level gauge bolt	1	18.6 ~ 23.5	1.9 ~ 2.4	13.7 ~ 17.4
Oil screen bolt	2	14.7 ~ 21.6	1.5 ~ 2.2	10.8 ~ 15.9
Water outlet pipe bolt	3	16.7 ~ 19.6	1.7 ~ 2.0	12.3 ~ 14.5
Water inlet pipe bolt	2	16.7 ~ 19.6	1.7 ~ 2.0	12.3 ~ 14.5
Water inlet pipe nut	1	16.7 ~ 19.6	1.7 ~ 2.0	12.3 ~ 14.5
Surge tank bolt(8×28)	3	18.6 ~ 23.5	1.9 ~ 2.4	13.7 ~ 17.4
Surge tank bolt(8×80)	2	18.6 ~ 23.5	1.9 ~ 2.4	13.7 ~ 17.4
Surge tank nut	2	18.6 ~ 23.5	1.9 ~ 2.4	13.7 ~ 17.4
Intake manifold bolt	4	18.6 ~ 23.5	1.9 ~ 2.4	13.7 ~ 17.4
Intake manifold nut	4	18.6 ~ 23.5	1.9 ~ 2.4	13.7 ~ 17.4
Surge tank bracket bolt	2	18.6 ~ 23.5	1.9 ~ 2.4	13.7 ~ 17.4
Exhaust manifold bolt	14	29.4 ~ 34.3	3.0 ~ 3.5	21.7 ~ 25.3
Heat protect bolt	6	16.7 ~ 21.6	1.7 ~ 2.2	12.3 ~ 15.9
Front muffler bolt	2	39.2 ~ 58.8	4.0 ~ 6.0	28.9 ~ 43.4

## TROUBLESHOOTING

Symptom	Suspect area	Remedy
Engine misfire with abnormal internal lower engine noises.	Worn crankshaft bearings. Loose or improper engine drive plate.	Replace the crankshaft and bearings as required. Repair or replace the drive plate as required.
	Worn piston rings. (Oil consumption may or may not cause the engine to misfire.)	Inspect the cylinder for a loss of compression. Repair or replace as required.
	Worn crankshaft thrust bearings	Replace the crankshaft and bearings as required.
Engine misfire with abnormal valve train noise.	Stuck valves. (Carbon buildup on the valve stem)	Repair or replace as required.
	Excessive worn or mis-aligned timing chain.	Replace the timing chain and sprocket as required.
	Worn camshaft lobes.	Replace the camshaft and valve lifters.
Engine misfire with coolant consumption.	<ul style="list-style-type: none"> <li>Faulty cylinder head gasket and/or cranking or other damage to the cylinder head and engine block cooling system.</li> <li>Coolant consumption may or may not cause the engine to overheat.</li> </ul>	<ul style="list-style-type: none"> <li>Inspect the cylinder head and engine block for damage to the coolant passages and/or a faulty head gasket.</li> <li>Repair or replace as required.</li> </ul>
Engine misfire with excessive oil consumption.	Worn valves, guides and/or valve stem seals.	Repair or replace as required.
	Worn piston rings. (Oil consumption may or may not cause the engine to misfire)	<ul style="list-style-type: none"> <li>Inspect the cylinder for a loss of compression.</li> <li>Repair or replace as required.</li> </ul>
Engine noise on start-up, but only lasting a few seconds.	Incorrect oil viscosity.	<ul style="list-style-type: none"> <li>Drain the oil.</li> <li>Install the correct viscosity oil.</li> </ul>
	Worn crankshaft thrust bearing.	<ul style="list-style-type: none"> <li>Inspect the thrust bearing and crankshaft.</li> <li>Repair or replace as required.</li> </ul>
Upper engine noise, regardless of engine speed.	Low oil pressure.	Repair or replace as required.
	Broken valve spring.	Replace the valve spring.
	Worn or dirty valve lifters.	Replace the valve lifters.
	Stretched or broken timing chain and/or damaged sprocket teeth.	Replace the timing chain and sprockets.
	Worn timing chain tensioner, if applicable.	Replace the timing chain tensioner as required.
	Worn camshaft lobes.	<ul style="list-style-type: none"> <li>Inspect the camshaft lobes.</li> <li>Replace the timing camshaft and valve lifters as required.</li> </ul>
	Worn valve guides or valve stems.	Inspect the valves and valve guides, then repair as required.
	Stuck valves. Carbon on the valve stem or valve seat may cause the valve to stay open.	Inspect the valves and valve guides, then repair as required.
	Worn drive belt, idler, tensioner and bearing.	Replace as required.

Symptom	Suspect area	Remedy
Lower engine noise, regardless of engine speed.	Low oil pressure.	Repair as required.
	Loose or damaged drive plate.	Repair or replace the drive plate.
	Damaged oil pan, contacting the oil pump screen.	<ul style="list-style-type: none"> <li>Inspect the oil pan.</li> <li>Inspect the oil pump screen.</li> <li>Repair or replace as required.</li> </ul>
	Oil pump screen loose, damaged or restricted.	<ul style="list-style-type: none"> <li>Inspect the oil pump screen.</li> <li>Repair or replace as required.</li> </ul>
	Excessive piston-to-cylinder bore clearance.	<ul style="list-style-type: none"> <li>Inspect the piston, piston pin and cylinder bore.</li> <li>Repair as required.</li> </ul>
	Excessive piston pin-to-piston clearance.	<ul style="list-style-type: none"> <li>Inspect the piston, piston pin and the connecting rod.</li> <li>Repair or replace as required.</li> </ul>
	Excessive connecting rod bearing clearance	Inspect the following components and repair as required. <ul style="list-style-type: none"> <li>The connecting rod bearings.</li> <li>The connecting rods.</li> <li>The crankshaft pin journals.</li> </ul>
	Excessive crankshaft bearing clearance.	Inspect the following components, and repair as required. <ul style="list-style-type: none"> <li>The crankshaft bearings.</li> <li>The crankshaft main journals.</li> <li>The cylinder block.</li> </ul>
Incorrect piston, piston pin and connecting rod installation	<ul style="list-style-type: none"> <li>Verify the piston pins and connecting rods are installed correctly.</li> <li>Repair as required.</li> </ul>	
Engine noise under load.	Low oil pressure	Repair or replace as required.
	Excessive connecting rod bearing clearance .	Inspect the following components and repair as required : <ul style="list-style-type: none"> <li>The connecting rod bearings.</li> <li>The connecting rods.</li> <li>The crankshaft.</li> </ul>
	Excessive crankshaft bearing clearance.	Inspect the following components, and repair as required. <ul style="list-style-type: none"> <li>The crankshaft bearings.</li> <li>The crankshaft main journals.</li> <li>The cylinder block.</li> </ul>



## EM-10

# Engine Mechanical System

Symptom	Suspect area	Remedy
Engine will not crank- crankshaft will not rotate.	Hydraulically locked cylinder. <ul style="list-style-type: none"><li>• Coolant/antifreeze in cylinder.</li><li>• Oil in cylinder.</li><li>• Fuel in cylinder.</li></ul>	<ol style="list-style-type: none"><li>1. Remove spark plugs and check for fluid.</li><li>2. Inspect for broken head gasket.</li><li>3. Inspect for cracked engine block or cylinder head.</li><li>4. Inspect for a sticking fuel injector and/or leaking fuel regulator.</li></ol>
	Broken timing chain and/or timing chain and/or timing chain gears.	<ol style="list-style-type: none"><li>1. Inspect timing chain and gears.</li><li>2. Repair as required.</li></ol>
	Material in cylinder. <ul style="list-style-type: none"><li>• Broken valve</li><li>• Piston material</li><li>• Foreign material</li></ul>	<ol style="list-style-type: none"><li>1. Inspect cylinder for damaged components and/or foreign materials.</li><li>2. Repair or replace as required.</li></ol>
	Seized crankshaft or connecting rod bearings.	<ol style="list-style-type: none"><li>1. Inspect crankshaft and connecting rod bearing.</li><li>2. Repair as required.</li></ol>
	Bent or broken connecting rod.	<ol style="list-style-type: none"><li>1. Inspect connecting rods.</li><li>2. Repair as required.</li></ol>
	Broken crankshaft.	<ol style="list-style-type: none"><li>1. Inspect crankshaft.</li><li>2. Repair as required.</li></ol>

## Compression pressure inspection

### NOTICE

If there is lack of power, excessive oil consumption or poor fuel economy, measure the compression pressure.

1. Warm up the engine until the normal operating temperature becoming 80~95°C(176~203°F).
2. Remove the surge tank.
3. Remove the ignition coil connectors(B) and ignition coils.

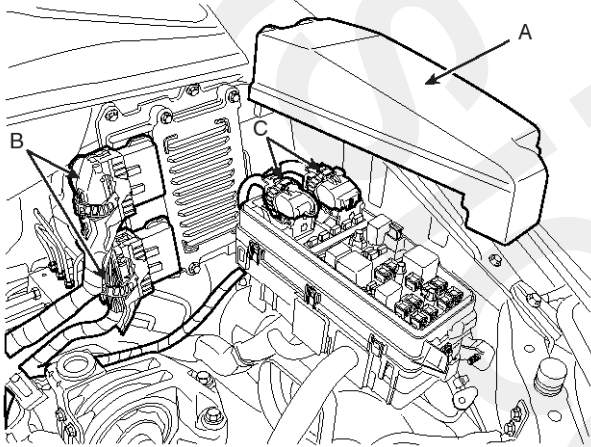

BCKG003A

4. Using a 16mm plug wrench, remove the 6 spark plugs.
5. Check cylinder compression pressure.
  - 1) Insert a compression gauge into the spark plug hole.
  - 2) Open the throttle fully.
  - 3) With the fully-open throttle in cranking, measure the compression pressure.

### NOTICE

Always use a fully charged battery to get the engine speed of 250 rpm or more.

Repeat steps 1) through 3) for each cylinder.

### NOTICE

This measurement must be done in as short a time as possible.

Compression pressure: 1,176.79kPa (12.0kgf/cm<sup>2</sup>, 170.68psi) - 200 ~ 250rpm

Minimum pressure: 1,029.69kPa (10.5kgf/cm<sup>2</sup>, 149.34psi)

Difference between cylinders: 98.07kPa (1.0kgf/cm<sup>2</sup>, 14.22psi)

- 4) If the compression pressure in 1 or more cylinders is lower than the specification above, pour a small amount of engine oil into the cylinder through the spark plug hole, repeat the steps (1) through (3) for the cylinder and measure the pressure again.

- If adding oil increases the pressure up, the piston rings or cylinder bores might be worn or damaged.
- If the pressure doesn't increase, a valve may be sticking or seating may be improper, or there may be leakage from the gasket.

6. Reinstall the spark plugs.

7. Install the ignition coils and connect ignition coil connectors.

8. Install the surge tank.

## VALVE CLEARANCE INSPECTION AND ADJUSTMENT

### NOTICE

Inspect and adjust the valve clearance when the engine is cold (Engine coolant temperature : 20°C±5°C(59~77°F)) and cylinder head is installed on the cylinder block.

1. Remove the engine cover.

2. Remove air cleaner assembly.

3. Remove the surge tank.

4. Remove the cylinder head cover.
  - 1) Disconnect the ignition coil connector and remove the ignition coil.
  - 2) Remove the cylinder head cover.

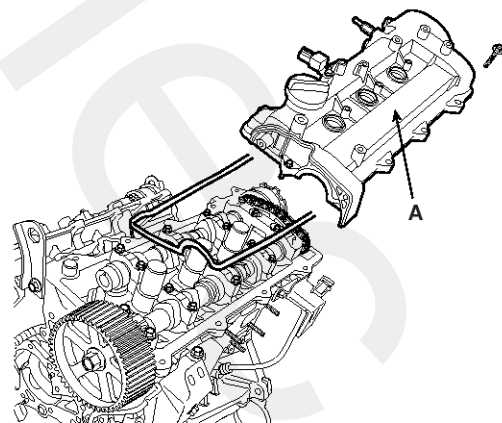

KCBF177A

5. Set the piston of the No.1 cylinder to TDC(Top Dead Center) position.
  - 1) Turn the crankshaft pulley clockwise and align its groove with the timing mark "T" of the timing chain cover.
  - 2) Check that the timing marks of the camshaft sprocket are in straight line on that of the cylinder head cover surface as shown in the illustration. It makes the piston of the No.1 cylinder position at TDC.

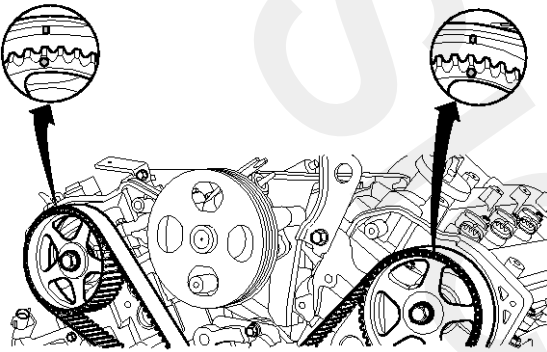

KCBF119B

### NOTICE

*If not, turn the crankshaft one revolution clockwise.*

6. Inspect the intake and the exhaust valve clearance.
  - 1) With the piston of the No.1 cylinder positioning at TDC, the valves which can be measured its clearance are as shown below.

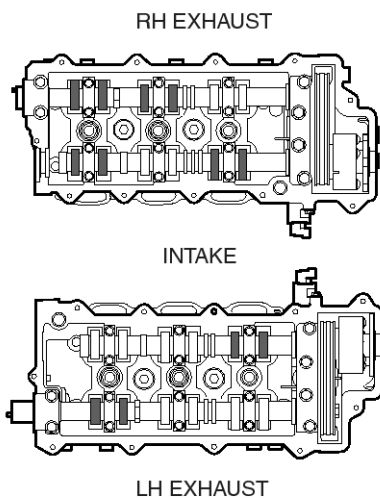

LDLG030A

Measurement method.

- Using a thickness gauge, measure the clearance between the tappet and the base circle of camshaft.
- Record the out-of-specification valve clearance measurements. They will be used later to determine the required adjusting tappet for replacement.

### Specification

Limit (Engine coolant temperature : 20°C [68°F])

Intake : 0.10 ~ 0.30mm (0.0039 ~ 0.0118in.)

Exhaust : 0.20 ~ 0.40mm (0.0079 ~ 0.0157in.)

- 2) Turn the crankshaft pulley one revolution (360°) clockwise and align the groove with the timing mark "T" of the timing chain cover.
- 3) With the piston of the No.4 cylinder positioning at TDC, the valves which can be measured its clearance are as shown below.

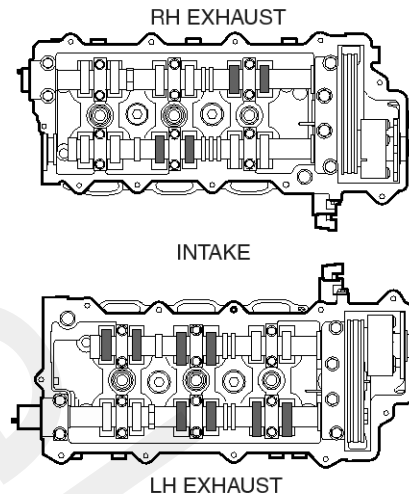

LDLG031A

7. Adjust the intake and the exhaust valve clearances.
  - 1) Set the piston of the No.1 cylinder to the TDC/position.
  - 2) Remove the timing belt.
  - 3) Remove the camshaft bearing caps(A, B).

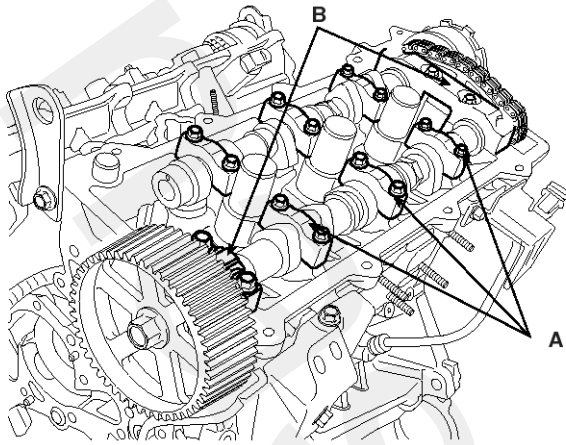

KCBF169A

- 4) Remove the camshaft assembly.
- 5) Remove MLA(Mechanical Lash Adjuster)s.
- 6) Measure the thickness of the removed tappet using a micrometer.

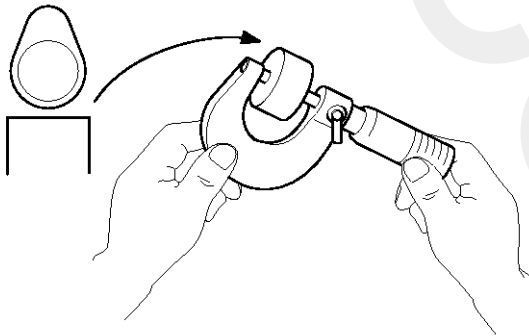

EDKE889D

- 7) Calculate the thickness of a new tappet so that the valve clearance comes within the specified value.

T : Thickness of removed tappet

A : Measured valve clearance

N : Thickness of new tappet

Intake :  $N = T + [A - 0.20\text{mm}(0.0079\text{in.})]$

Exhaust :  $N = T + [A - 0.25\text{mm}(0.0098\text{in.})]$

- 8) Select a new tappet with a thickness as close as possible to the calculated value.

### NOTICE

Tappets are available with 41 different size increments of 0.015mm (0.0006in.) from 3.00mm (0.118in.) to 3.600mm (0.1417in.)

- 9) Place a new tappet on the cylinder head.

### NOTICE

Apply engine oil on the periphery surface of the selected tappet.



- 10) Install the intake and exhaust camshafts.
- 11) Install the bearing caps.
- 12) Install the timing belt.
- 13) Turn the crankshaft two revolutions in the operating direction(clockwise) and realign crankshaft sprocket and camshaft sprocket timing marks(A).
- 14) Recheck the valve clearance.

Specification (Engine coolant temperature: 20°C[68°F])

Intake : 0.17 ~ 0.23mm (0.0067 ~ 0.0090in.)

Exhaust : 0.27 ~ 0.33mm (0.0106 ~ 0.0129in.)

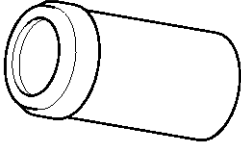
## SPECIAL TOOLS

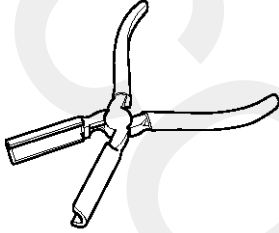
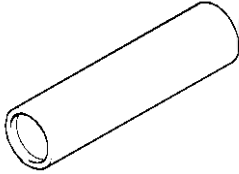
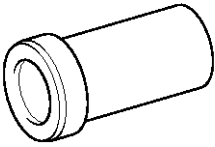
Tool (Number and name)	Illustration	Use
Crankshaft front oil seal installer (09214-33000)		Installation of the front oil seal
Torque angle adapter (09221-4A000)		Installation of bolts & nuts needing an angular method
Valve stem seal remover (09222-29000)		Removal of the valve stem seal
Valve stem seal installer (09222-22001)		Installation of the valve stem seal
Camshaft oil seal installer (09214-21000)		Installation of the camshaft oil seal

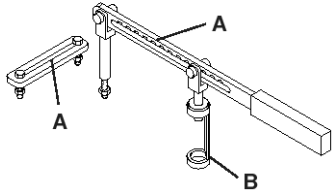
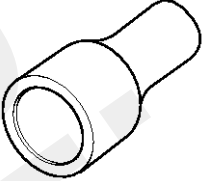
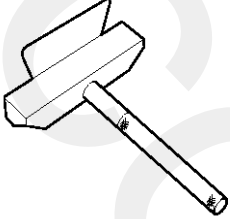
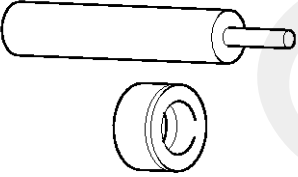
Tool (Number and name)	Illustration	Use
Valve spring compressor & holder (09222-3K000) (09222-3C300)		Removal and installation of the intake or exhaust valves. A : 09222-3K000 B : 09222-3C300 (holder)
Crankshaft rear oil seal installer (09231-33000)		Installation of the crankshaft rear oil seal
Oil pan remover (09215-3C000)		Removal of oil pan
Valve guide installer (09221-3F100 A/B)		Removal and installation of the valve guide

## Engine And Transaxle Assembly

## REMOVAL

## ⚠ CAUTION

- Use fender covers to avoid damaging painted surfaces.
- To avoid damage, unplug the wiring connectors carefully while holding the connector portion.

## 📌 NOTICE

- Mark all wiring and hoses to avoid misconnection.
1. Remove the engine cover.
  2. Disconnect the neagative terminal from the battery and remove the battery(A).

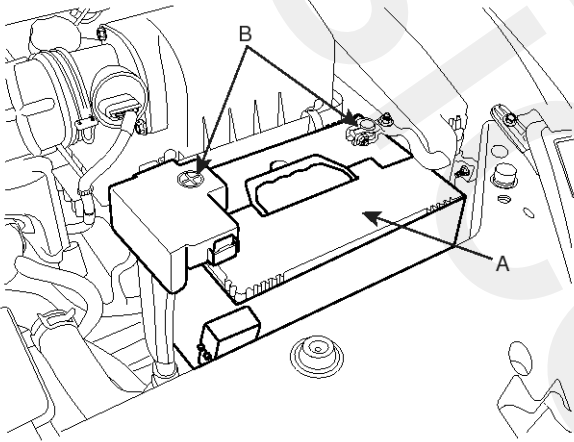

SVQM16001L

3. Remove the intake air hose and air cleaner assembly.
  - 1) Disconnect the MAF connector(A).
  - 2) Disconnect the breather hose(B) from air cleaner hose.
  - 3) Remove the intake air hose and air cleaner assembly(C).

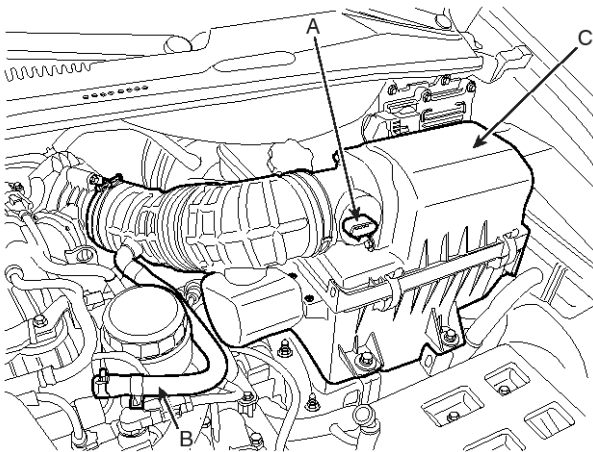

BCKG002A

4. Remove the battery tray(A).

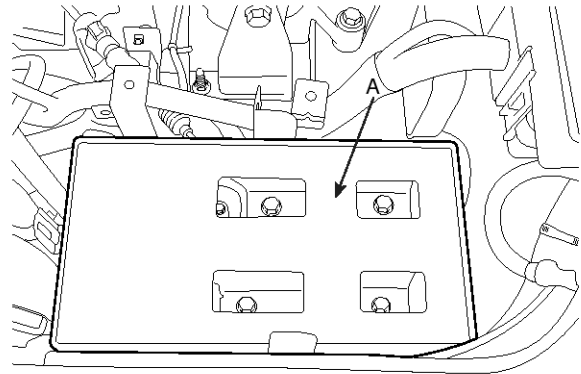

ACKF065A

5. Remove the under cover.

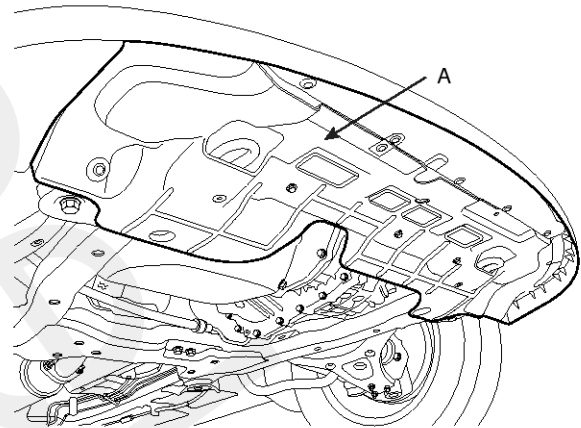

ACKF064A

6. Drain the engine coolant.
7. Remove the upper radiator hose(A) and lower radiator hose(B).

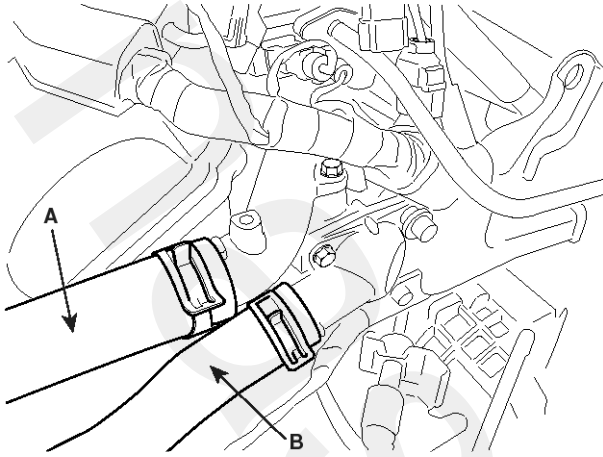

LDLG008A

8. Remove the transaxle oil cooler hoses(A/T vehicles only).
9. Remove the fuel inlet hose(A) from the delivery pipe.

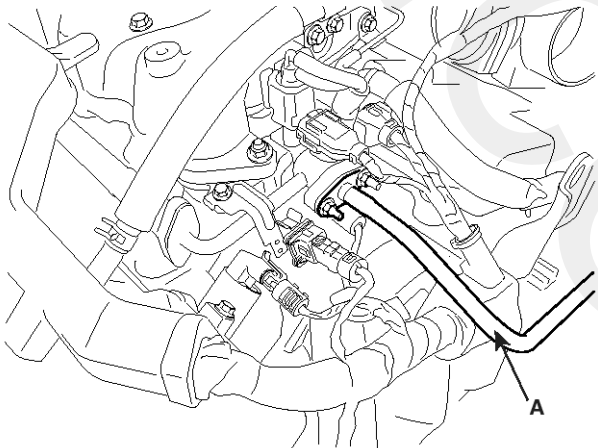

LDLG062A

10. Disconnect the engine wiring harness connectors.

- 1) Disconnect the No.1/No.2 knock sensor connectors(A,B), the oil pressure switch connector(C), the ignition coil harness(D) and the No.1 VIS(Variable Induction System) connector(E).

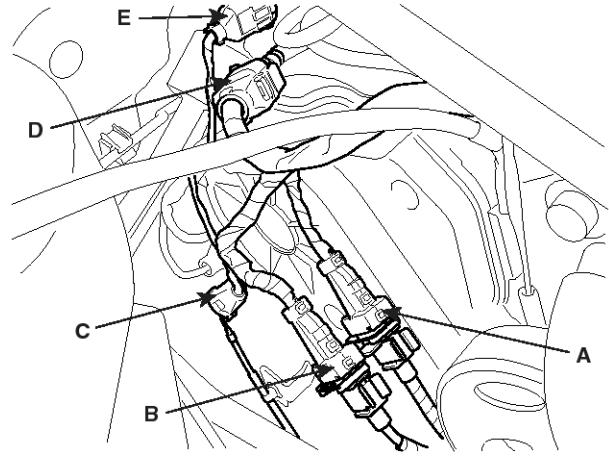

LDLG005A

- 2) Disconnect the bank 1 front/rear O2 sensor connectors(A).

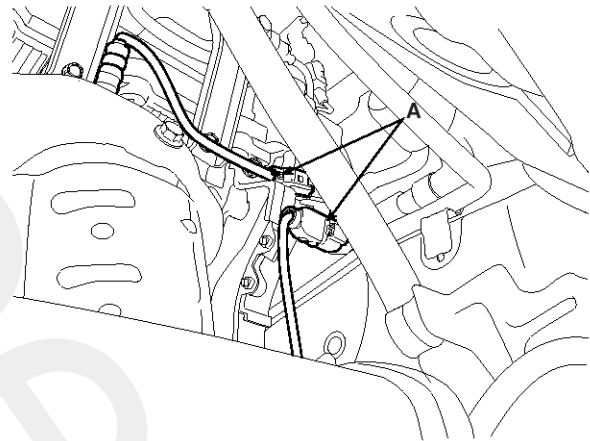

KCBF160A

- 3) Disconnect the injection connectors(A,B,C), the ground lines(D), the condenser connector(E) and the Ignition coil connectors(F).

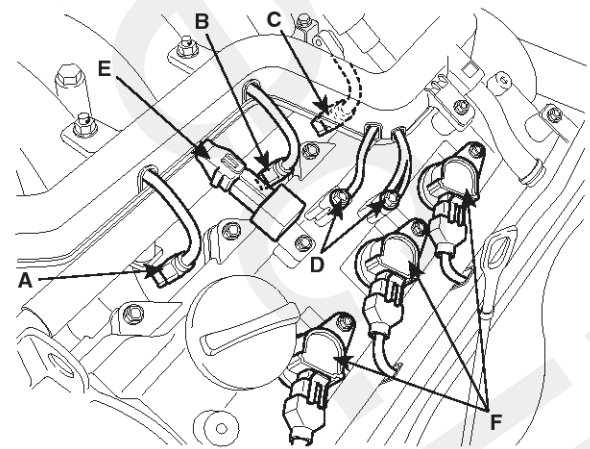

LDLG060A



- 4) Disconnect the injection harness connector(A), the No.2 VIS(Variable Induction System) connector(B), the No.1/No.2 OCV(Oil Control Valve) connectors(C,D) and the OTS(Oil Temperature Sensor) connector(E).

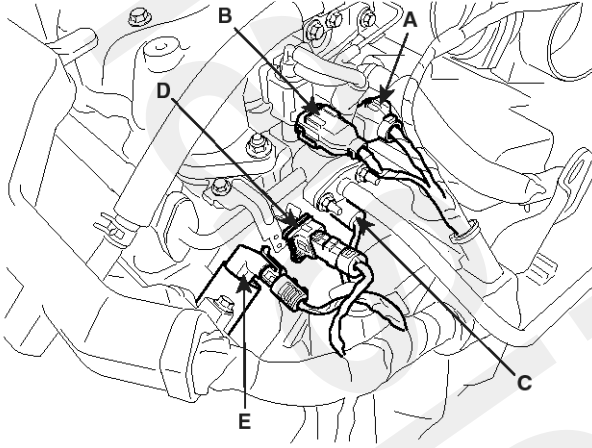

LDLG006A

- 5) Disconnect the MAPS(Manifold Absolute Pressure Sensor) connector(A), the ETC(Electronic Throttle Control) connector(B) and the PCSV(Purge Control Solenoid Valve) connector(C).

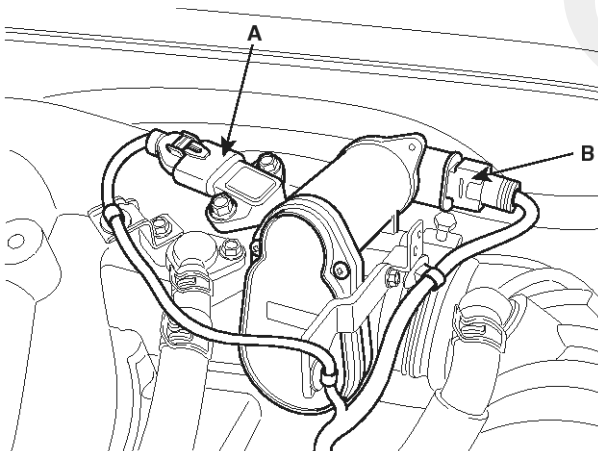

LDLG034A

- 6) Remove the cooling fan relay cable(A).

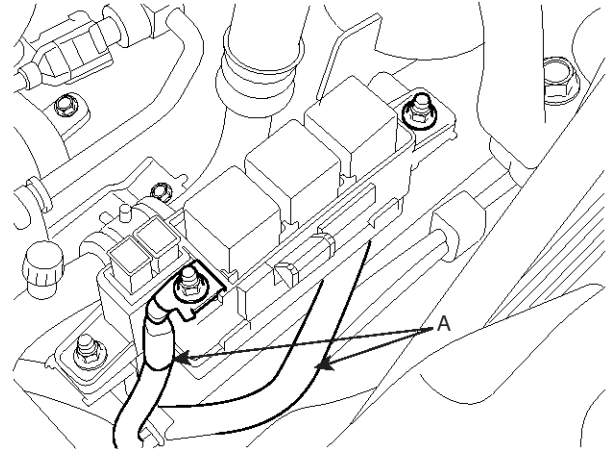

SVQM16008L

- 7) Disconnect the generator connector(A) and the air conditioning compressor connector(B).

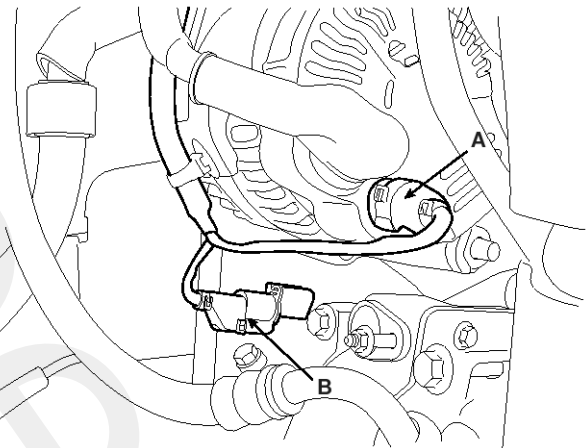

KCBF151A

- 8) Disconnect the bank 2 CMP sensor connector(A) and the WTS(Water Temperature Sensor) connector(B).

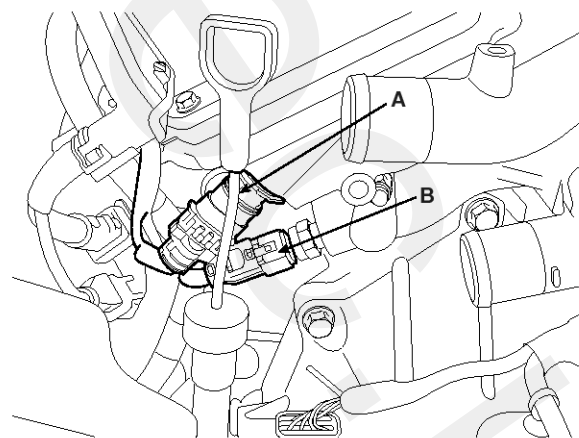

KCBF155A

- 9) Disconnect the bank 2 front/rear O2 sensor connectors(A,B) and the CKP sensor connector(C).

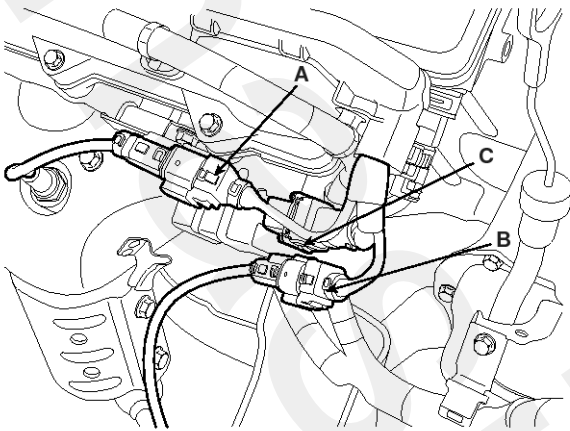

KCBF154A

- 10) Disconnect the bank 1 CMP sensor connector(A).

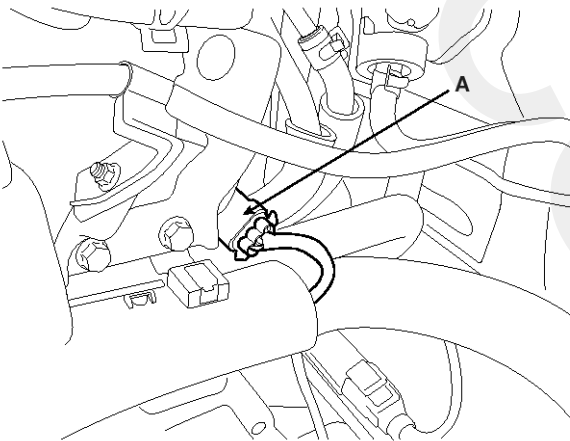

KCBF152A

11. Disconnect engine wiring.

- 1) Remove the engine room fuse and relay box cover(A).
- 2) Disconnect the PCM connectors(B).
- 3) Disconnect the FAM connectors(C)(Refer to HA group).

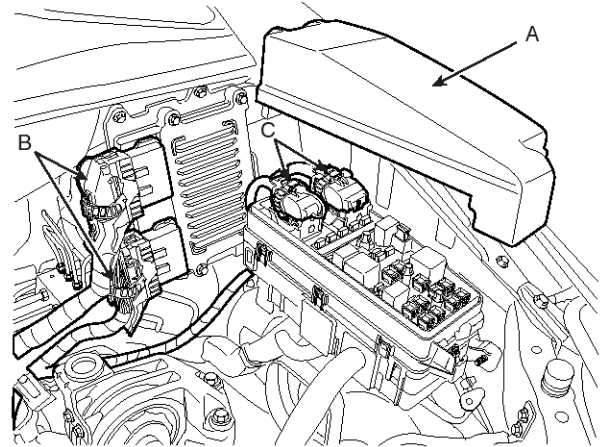

BCKG003A

- 4) Unscrew the FAM mounting bolts(D-3EA) and take the FAM(E) out of the splash shield(F).
- 5) Disconnect the connector(G) from the splash shield(B).

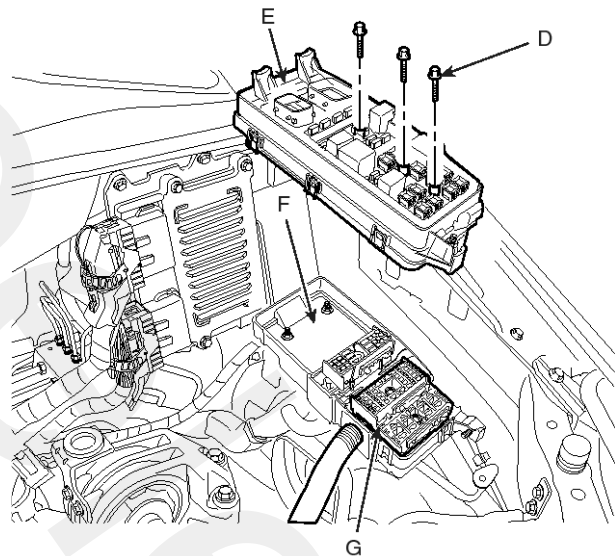

BCKG004A

12. Remove the heater hoses.

13. Disconnect the brake vacuum hose(A).

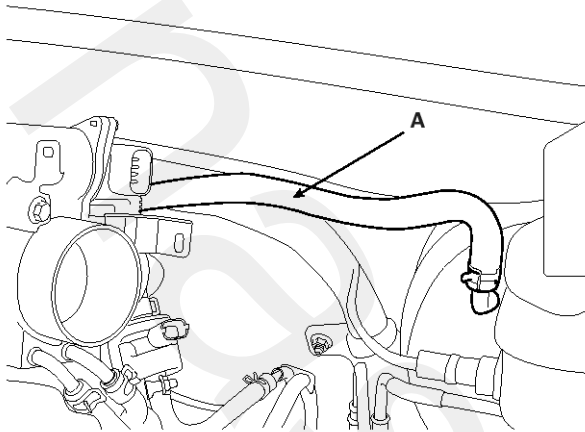

LDLG036A

14. After draining or gathering power steering fluid, disconnect the power steering hose(A).
15. Remove the radiator grille upper cover(A) for convenience sake.

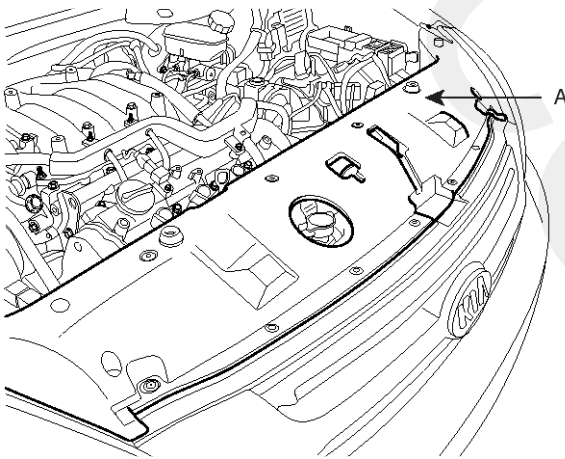

SVQM16002L

16. Disconnect the power steering return hose.
17. Remove the radiator support upper member assembly(A) for convenience sake.

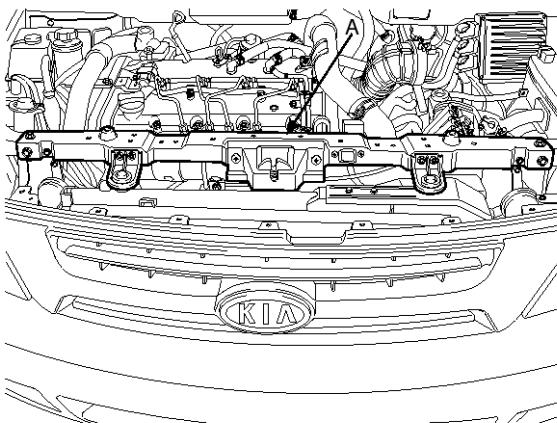

ACKF047A

**NOTICE**

The bottom side bolt(A) which can be seen after removing the under cover should be loosened for removal of the radiator support upper member assembly.

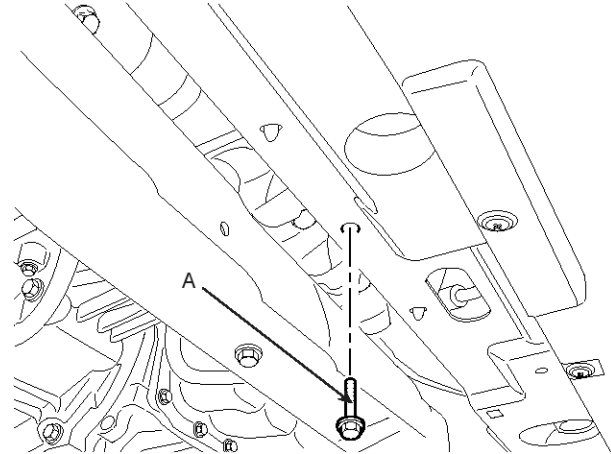

BCKG010A

18. Drain engine oil.
19. Remove the brake caliper.(Refer to DS group).
20. Disconnect the air conditioning compressor hoses.(Refer to HA group).
21. Remove the front wheels and tires.(Refer to DS group).
22. Remove the brake caliper hub nut.(Refer to DS group).
23. Remove the tie rod end ball joint from the knuckle.(Refer to DS group)
24. Remove the driver shaft and the stabilizer bar link(Refer to SS group).
25. Remove the front muffler(A).

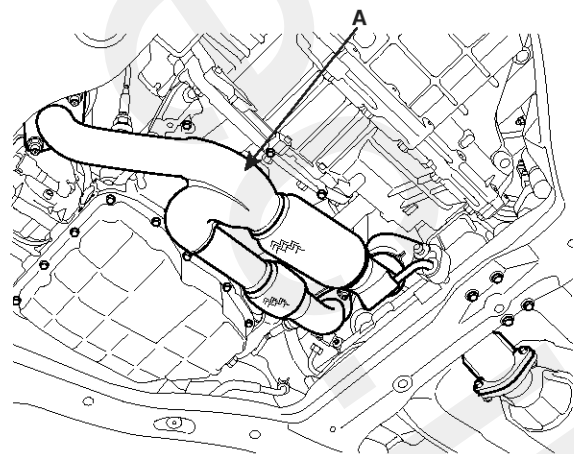

KCBF102A

26. Using a floor jack, support the engine and transaxle assembly.

## NOTICE

After removing the sub frame mounting bolt, the engine and transaxle assembly may fall downward, and so support them securely with floor jack.

Verify that the hoses and connectors are disconnected before removing the engine and transaxle assembly.

27. Remove the engine mounting bracket(A) and the ground(B).

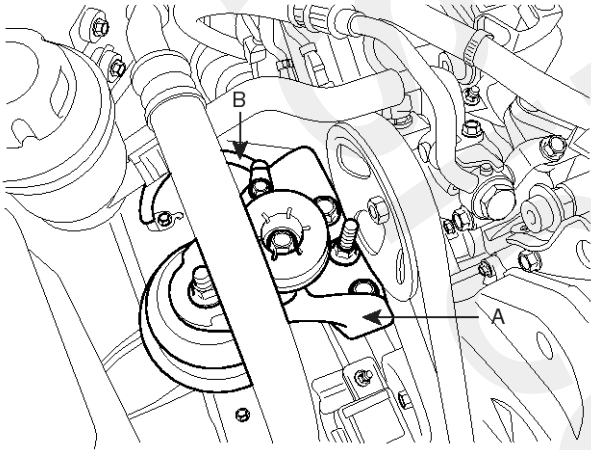

SVQM16005L

28. Remove the transaxle insulator mounting bolt(A).

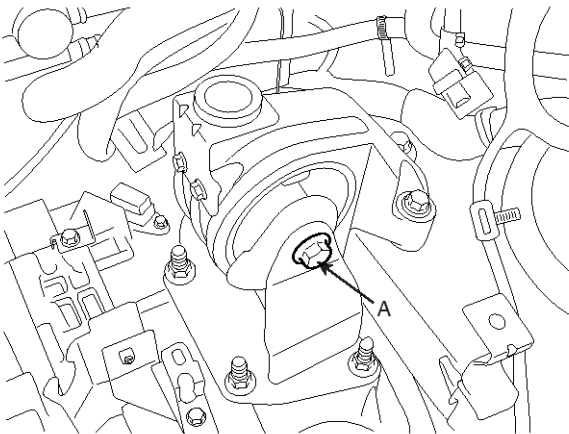

ACKF075A

## NOTICE

Remove the ECM(Electronic Controlled Mounting) nuts and the solenoid valve connector for A/T vehicles.

29. Supporting the engine and transaxle assembly with a jack, remove the assembly from the vehicle by loosening the sub frame mounting bolts and lifting up the vehicle slowly.

## NOTICE

When removing the engine and transaxle assembly, be careful not to damage any surrounding parts or body components.

### Front

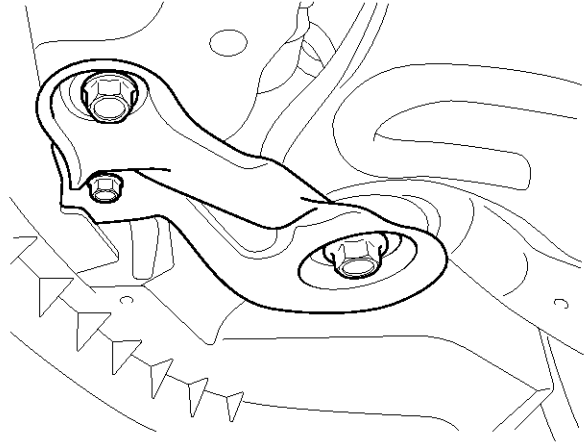

SVQM16007L

### Rear

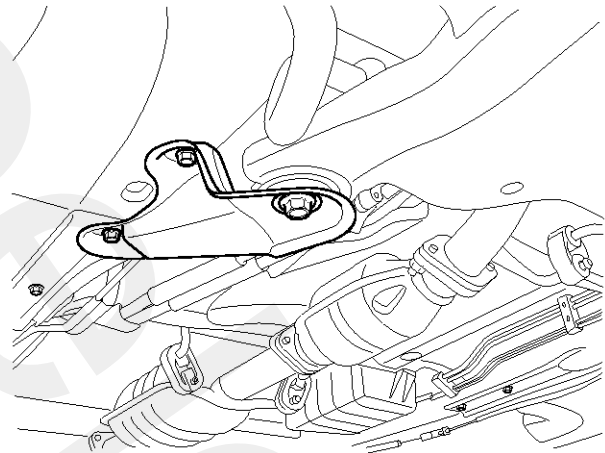

SVQM16006L

## INSTALLATION

Installation is in the reverse order of removal.

Perform the following :

- Adjust the shift cable.
- Refill the engine with engine oil.
- Refill the transaxle with fluid.
- Refill the radiator with engine coolant.
- Bleed air from the cooling system with the heater valve open.
- Clean the battery posts and cable terminals with sandpaper assemble them, then apply grease to prevent corrosion.
- Inspect for fuel leakage.

After assembling the fuel line, turn on the ignition switch (do not operate the starter) so that the fuel pump runs for approximately two seconds and fuel line pressurizes.

Repeat this operation two or three times, then check for fuel leakage at any point in the fuel line.

## Timing System COMPONENTS

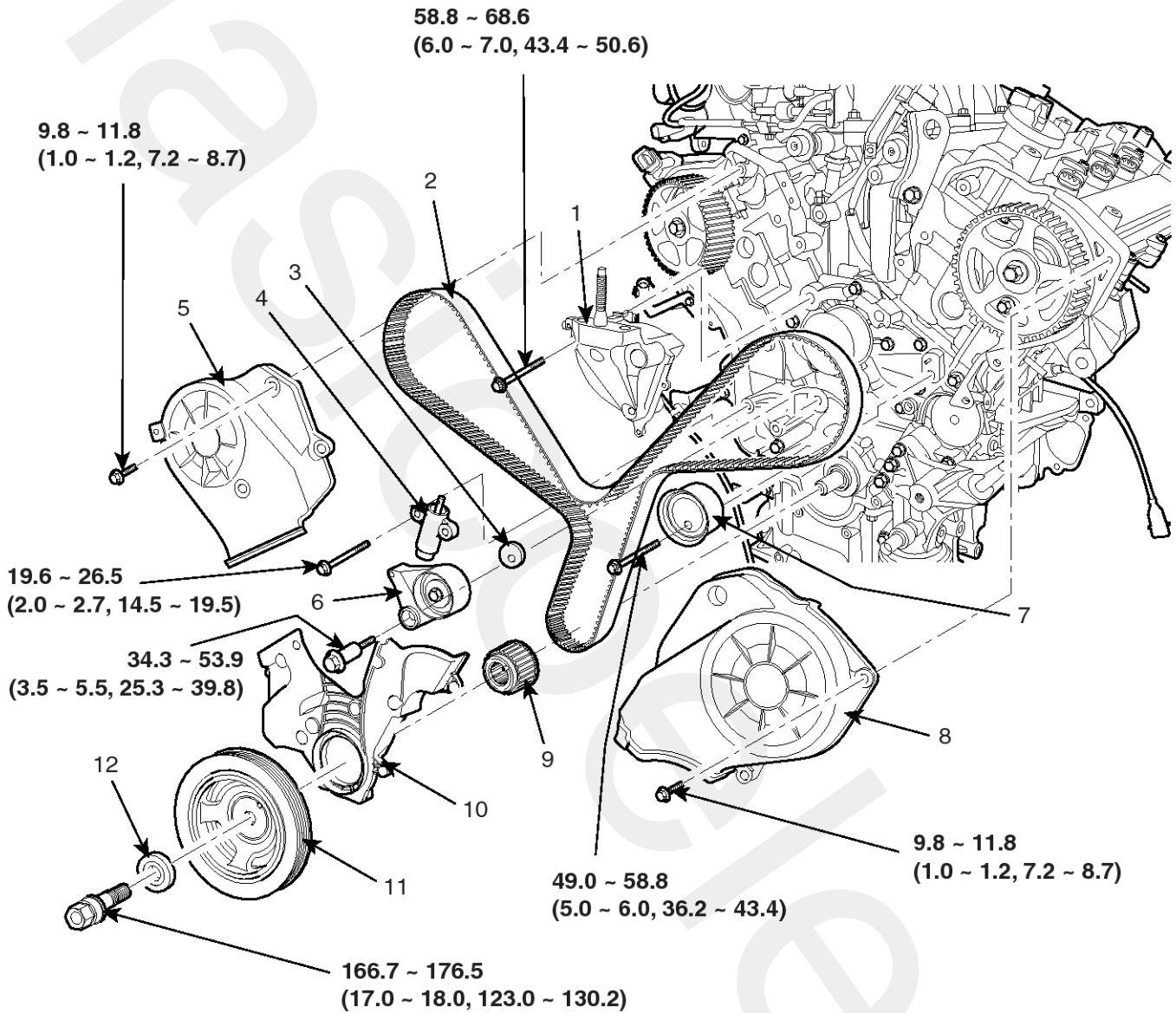

### TORQUE : N.m (kgf.m, lb-ft)

- |                                       |                                   |
|---------------------------------------|-----------------------------------|
| 1. Engine support bracket             | 7. Idler pulley                   |
| 2. Timing belt                        | 8. Bank 2 timing belt upper cover |
| 3. Tensioner arm assembly washer      | 9. Crankshaft sprocket            |
| 4. Timing belt auto tensioner         | 10. Timing belt lower cover       |
| 5. Bank 1 timing belt upper cover     | 11. Damper pulley                 |
| 6. Timing belt tensioner arm assembly | 12. Special washer                |

## REMOVAL

1. Remove the engine cover.
2. Remove the front right wheel and tire.
3. Remove the right side cover.
4. Remove the drive belt(A), the idler(B) and the tensioner(C).

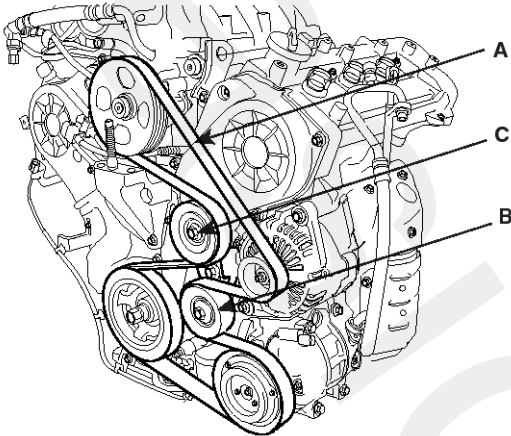

KCBF105B

**NOTICE**

In removing the drive belt, fix a tool in the auto tensioner pulley bolt and turn the bolt counter clockwise.

5. Remove the timing belt upper cover(A).

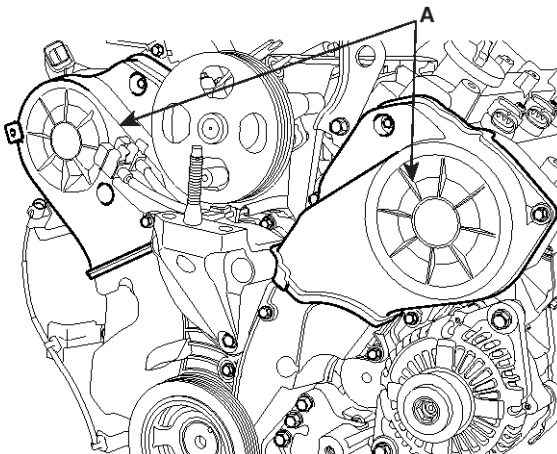

KCBF106A

6. Align the groove of the pulley with the timing mark of the timing belt cover by turning the crankshaft pulley clockwise. Check if the timing mark of the camshaft sprocket is aligned with that of the cylinder head cover at the moment.

(No.1 cylinder piston at TDC)

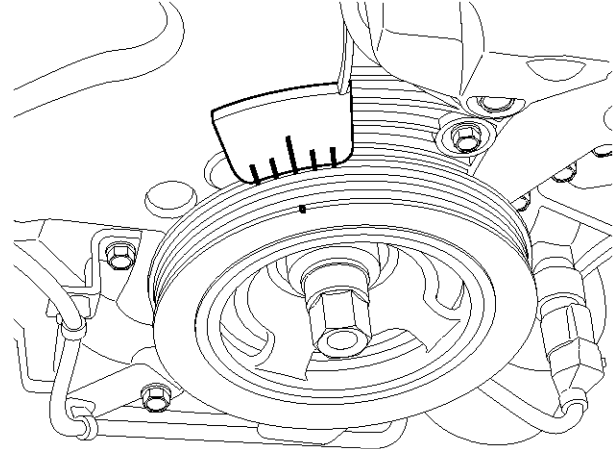

KCBF107A

7. Remove the engine mounting bracket(A).

**NOTICE**

Sustain the engine oil pan with a jack.

**CAUTION**

Put a wooden or rubber block between the jack and the engine oil pan.

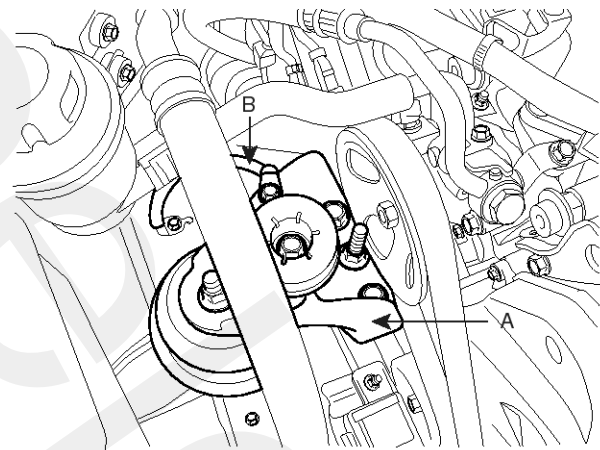

SVQM16005L

8. Remove the crankshaft damper pulley(A).

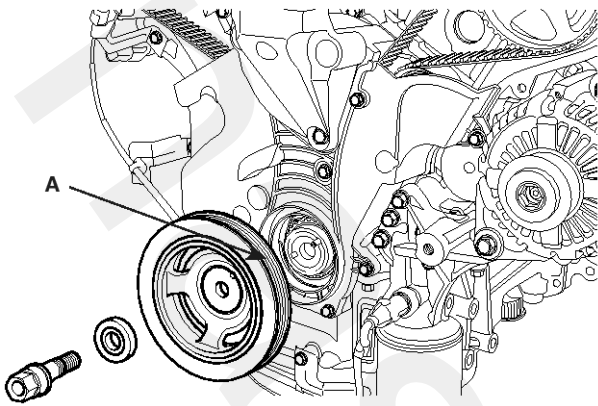

KCBF109A

9. Remove the timing belt lower cover(A).

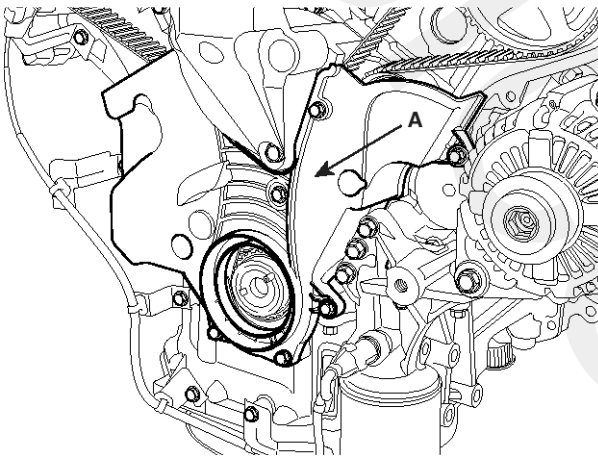

KCBF110A

10. Remove the engine support bracket(A).

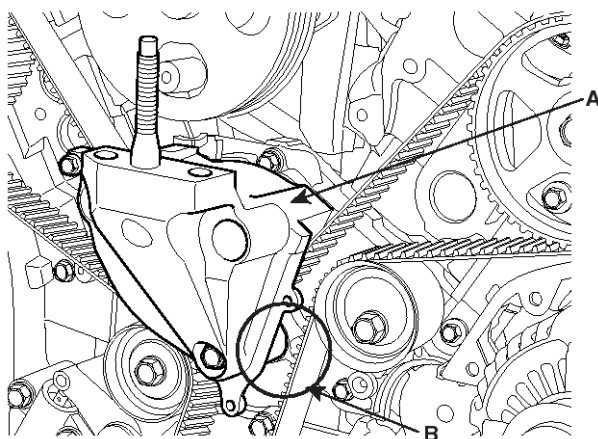

LDLG065A

## NOTICE

After the removal, engine coolant can be drained a little from that point(B) which is a matter of no importance.

11. Remove the timing belt auto tensioner(A).

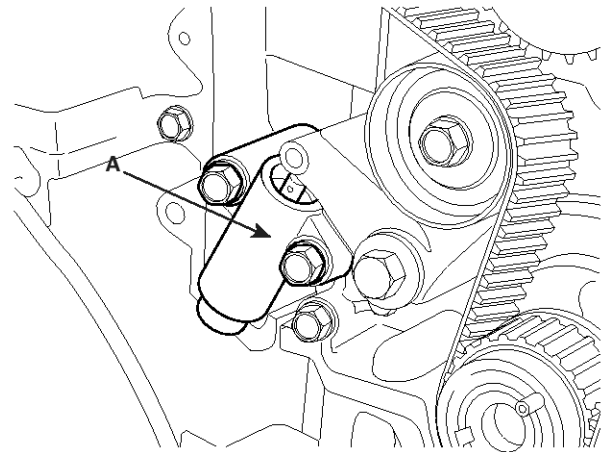

KCBF112A

12. Remove the timing belt(A).

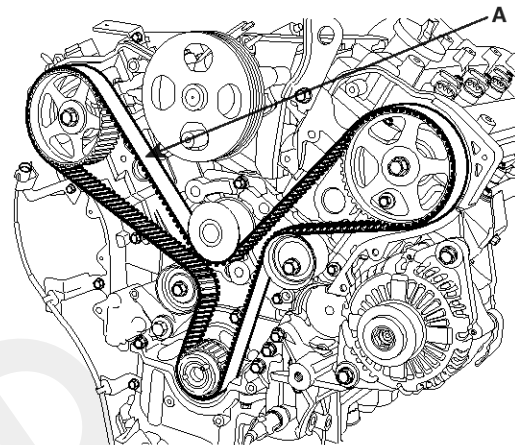

KCBF113A

## NOTICE

Make a direction mark of revolution on the timing belt for reusal.

13. Remove the tensioner arm assembly(A) and the idler(B).



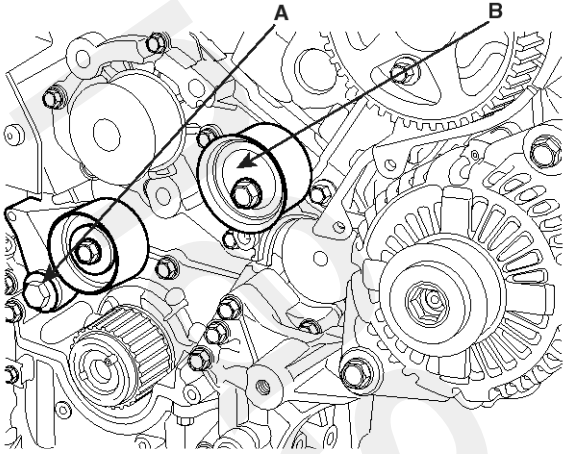

KCBF114A

14. Remove the crankshaft sprocket.

## INSPECTION

### SPROCKETS, TENSIONER, IDLER

1. Check the camshaft sprocket and crankshaft sprocket, tensioner pulley and idler pulley for abnormal wear, cracks, or damage. Replace as necessary.
2. Inspect the tensioner and the idler for easy and smooth rotation and check for play or noise. Replace as necessary.

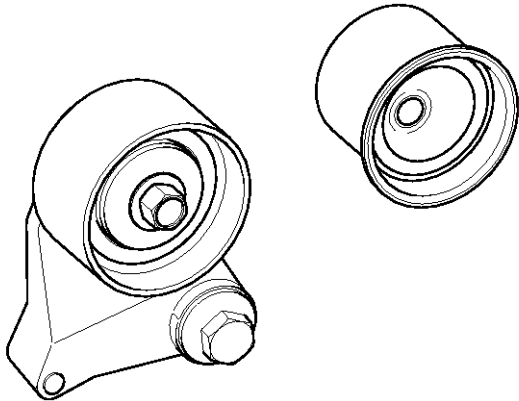

KCBF115A

3. Replace the tensioner and the idler if grease is leaked from bearings.

### TIMING BELT

1. Check the belt for oil or dust deposits. Replace, if necessary.  
Small deposits should be wiped away with a dry cloth or paper. Do not clean with solvent.
2. When the engine is overhauled or belt tension adjusted, check the belt carefully. If any of the

following flaws are evident, replace the belt.

#### NOTICE

- Do not bend, twist or turn the timing belt inside out.
  - Do not allow the timing belt to come into contact with oil, water and steam.
3. Inspect the idler for easy and smooth rotation and check for play or noise.

## INSTALLATION

1. Install the crankshaft sprocket.
2. Install the tensioner arm assembly(A) and the idler(B).

### Tightening torque

Tensioner arm bolt : 34.3 ~ 53.9Nm(3.5 ~ 5.5kgf.m, 25.3~ 39.8lb-ft)

Idler pulley bolt : 49.0 ~ 58.8Nm(5.0 ~ 6.0kgf.m, 36.2~ 43.4lb-ft)

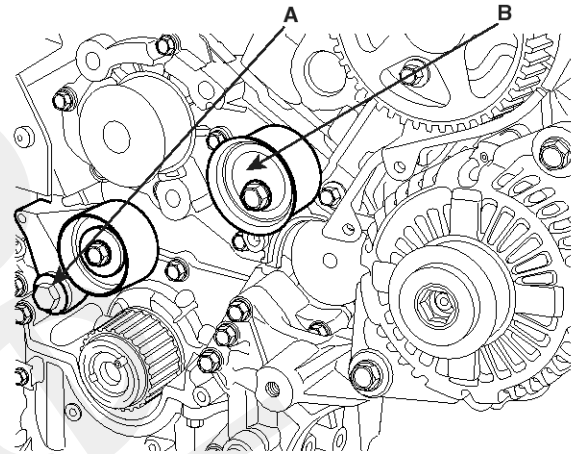

KCBF114A

3. Install the timing belt auto tensioner.
  - 1) Fixing the tensioner with a vice and compressing the rod, insert a set-pin.

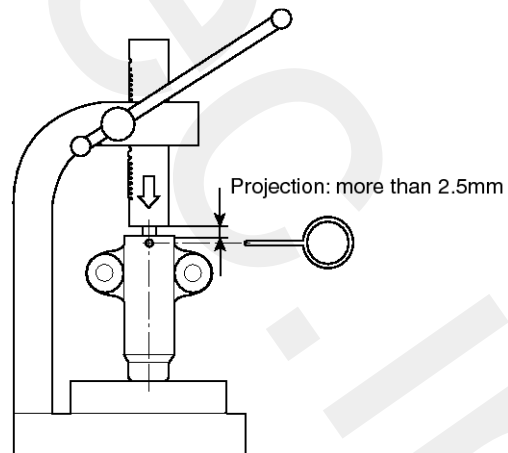

SCMEM6300L

## NOTICE

- Handle the auto tensioner in the vertical position.
- If it is treated by laying, tilting or turning over, stand it vertically for about five minutes in order for air to move upward.
- Do not pull the pin out before its installation to the engine assembly because pulling the pin can cause noise of timing system by making air go in the high pressure chamber.

## CAUTION

- When pressing the rod, use a vertical vice certainly.
- There is a high possibility for air to get in the high pressure chamber, when using a horizontal vice.
- Do not apply more load than 400N on the rod.
- Do not press the rod until its position is below 2.5mm from the body surface.
- The projection of the rod is secured more than 2.5mm.

## NOTICE

- Repairing orders when disassembling the auto tensioner and reassembling it to the engine, or pulling the pin out before its installation ;

1. Stand it vertically for about five minutes.
2. Press the rod with the force, 150~200N.
3. If the rod has a stiffness, press it slowly and insert the pin into the set hole.
4. If not(the tensioner is in 'sponge' state), press the rod slowly from its maximum projection to 2.9mm position(the meeting point with the rod and the hole of the body) two or three times.

Afterwards, if stiffness is sensed, insert the pin into the hole. However, if not, scrap the tensioner.

- 2) Install the auto tensioner(A) to the front case with the set-pin inserted.

## Tightening torque

19.6 ~ 26.5Nm(2.0 ~ 2.7kgf.m, 14.5 ~ 19.5lb-ft)

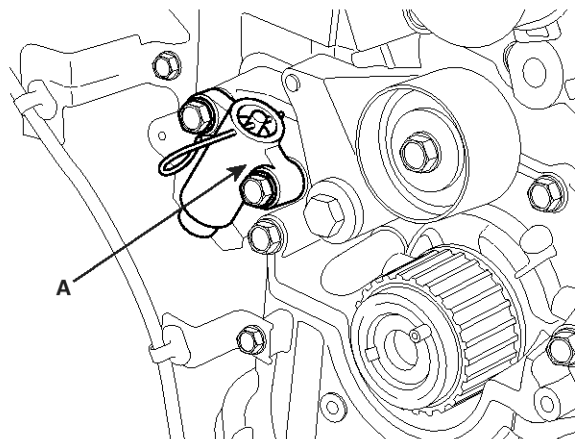

KCBF117A

4. Ensure the timing marks on the camshaft and the crankshaft sprockets.

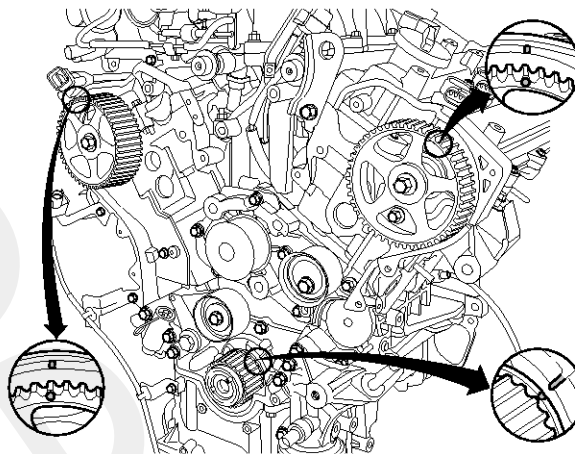

LDLG066A

5. Install the timing belt.

Crankshaft sprocket(A) → Idler(B) → Bank 2 exhaust camsprocket(C) → Water pump pulley(D) → Bank 1 exhaust camsprocket(E) → Tensioner pulley(F).

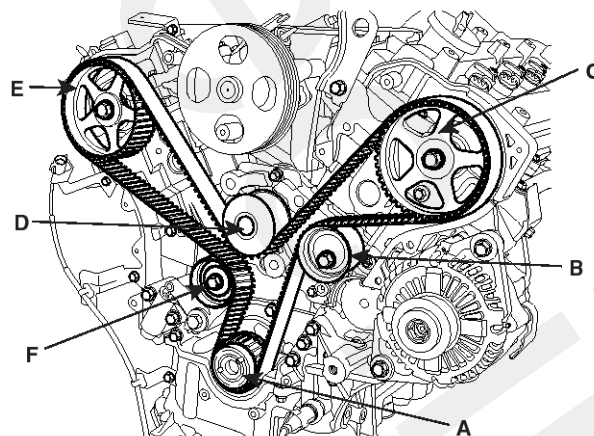

LDLG067A

6. Remove the auto tensioner set-pin.
7. Check the tension of the timing belt.
  - 1) Turn the crankshaft 2 rev. clockwise which makes the No.1 cylinder piston position at TDC.

After 5minutes, measure the length of the projected rod.

**Specification**

5 ~ 7mm(0.1969 ~ 0.2756in.)

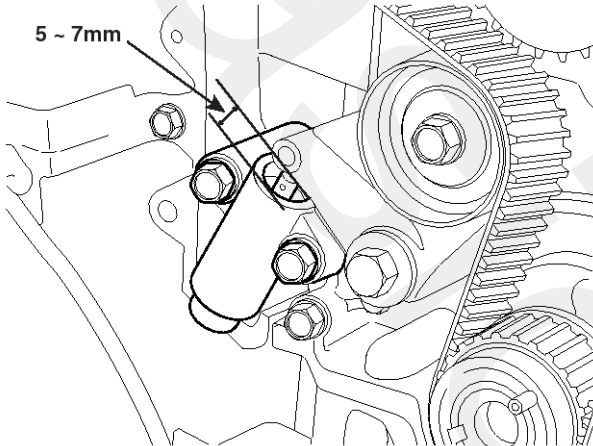

KCBF112B

- 2) Ensure the locations of the timing marks for each sprocket.
8. Install the engine support bracket(A).

**Tightening torque**

58.8 ~ 68.6Nm(6.0 ~ 7.0kgf.m, 43.4 ~ 50.6lb-ft)

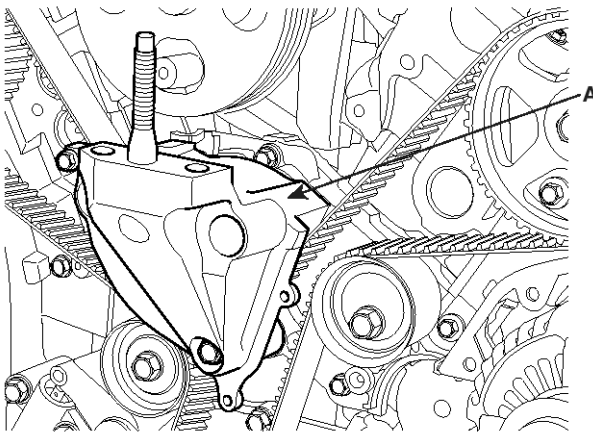

LDLG068A

9. Install the timing belt lower cover(A).

**Tightening torque**

9.8 ~ 11.8Nm(1.0 ~ 1.2kgf.m, 7.8 ~ 8.7lb-ft)

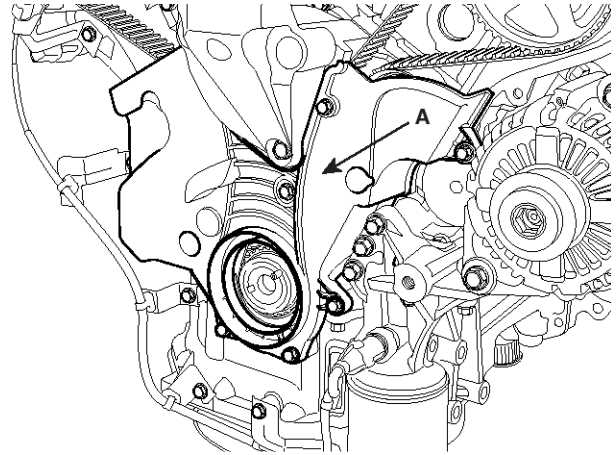

KCBF110A

10. Install the crankshaft damper pulley(A).

**Tightening torque**

166.7 ~ 176.5Nm(17.0 ~ 18.0kgf.m, 123.0 ~ 130.2lb-ft)

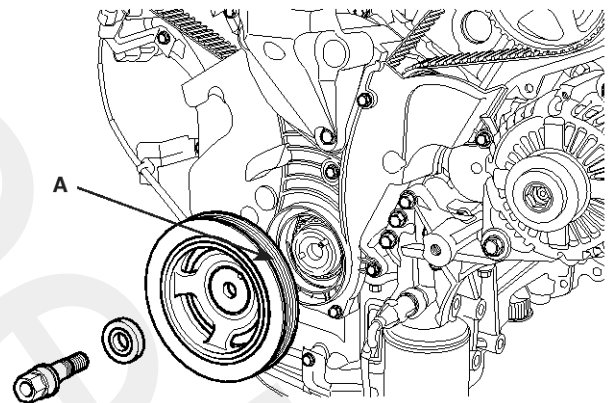

KCBF109A

11. Install the engine mounting bracket(A).

**Tightening torque**

63.7 ~ 83.4Nm(6.5 ~ 8.5kgf.m, 47.0 ~ 61.5lb-ft)

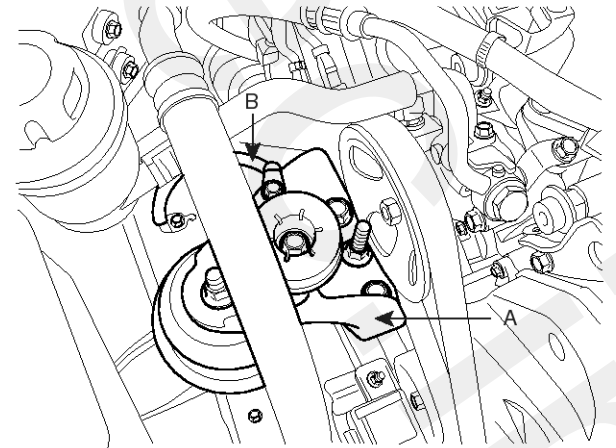

SVQM16005L

12. Install the timing belt upper cover(A).

---

**Tightening torque**

9.8 ~ 11.8Nm(1.0 ~ 1.2kgf.m, 7.2 ~ 8.7lb-ft)

---

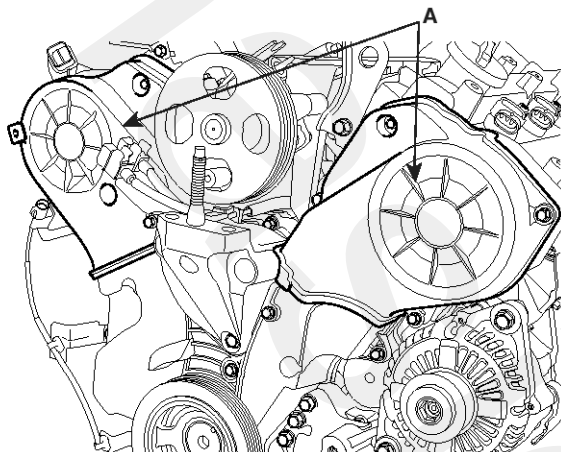

KCBF106A

13. Install the drive belt tensioner(C).

---

**Tightening torque**

34.3 ~ 53.9Nm(3.5 ~ 5.5kgf.m, 25.3 ~ 39.8lb-ft)

---

14. Install the drive belt idler and the drive belt(A).

---

**Tightening torque**

34.3 ~ 53.9Nm(3.5 ~ 5.5kgf.m, 25.3 ~ 39.8lb-ft)

---

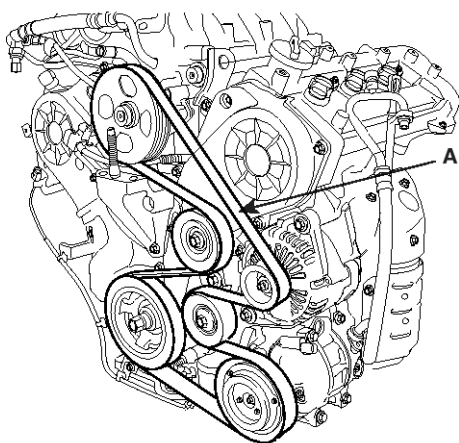

KCBF105A

15. Install the right side cover.

16. Install the front right wheel and tire.

17. Install the engine cover.

## Cylinder Head Assembly COMPONENTS

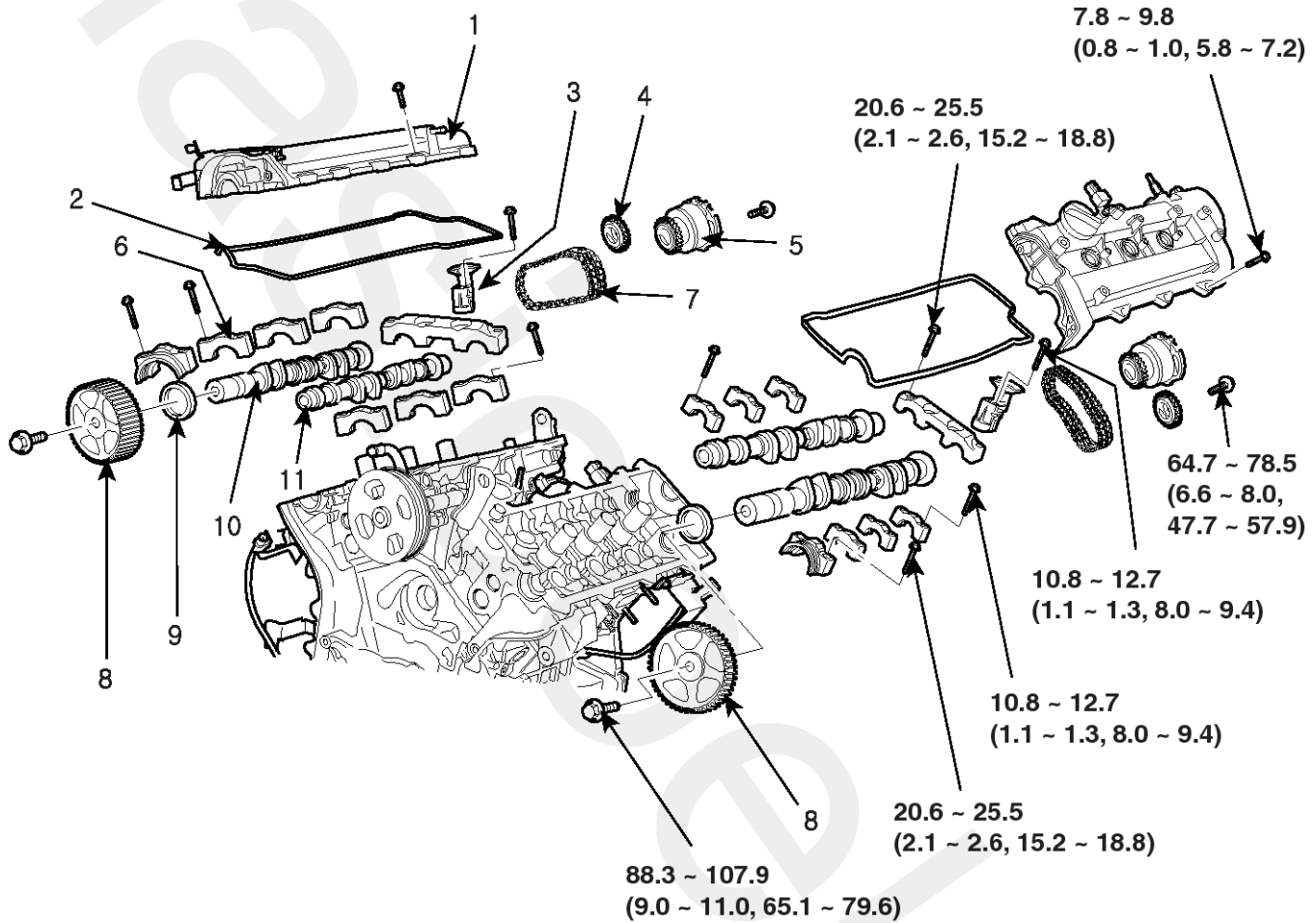

### TORQUE : N.m (kgf.m, lb-ft)

- |                                    |                              |
|------------------------------------|------------------------------|
| 1. Cylinder head cover             | 7. Timing chain              |
| 2. Cylinder head cover gasket      | 8. Exhaust camshaft sprocket |
| 3. Timing chain auto tensioner     | 9. Camshaft oil seal         |
| 4. Exhaust camshaft chain sprocket | 10. Exhaust camshaft         |
| 5. CVVT assembly                   | 11. Intake camshaft          |
| 6. Camshaft bearing cap            |                              |

24.5 (2.5, 18.1) + 60° + 45°

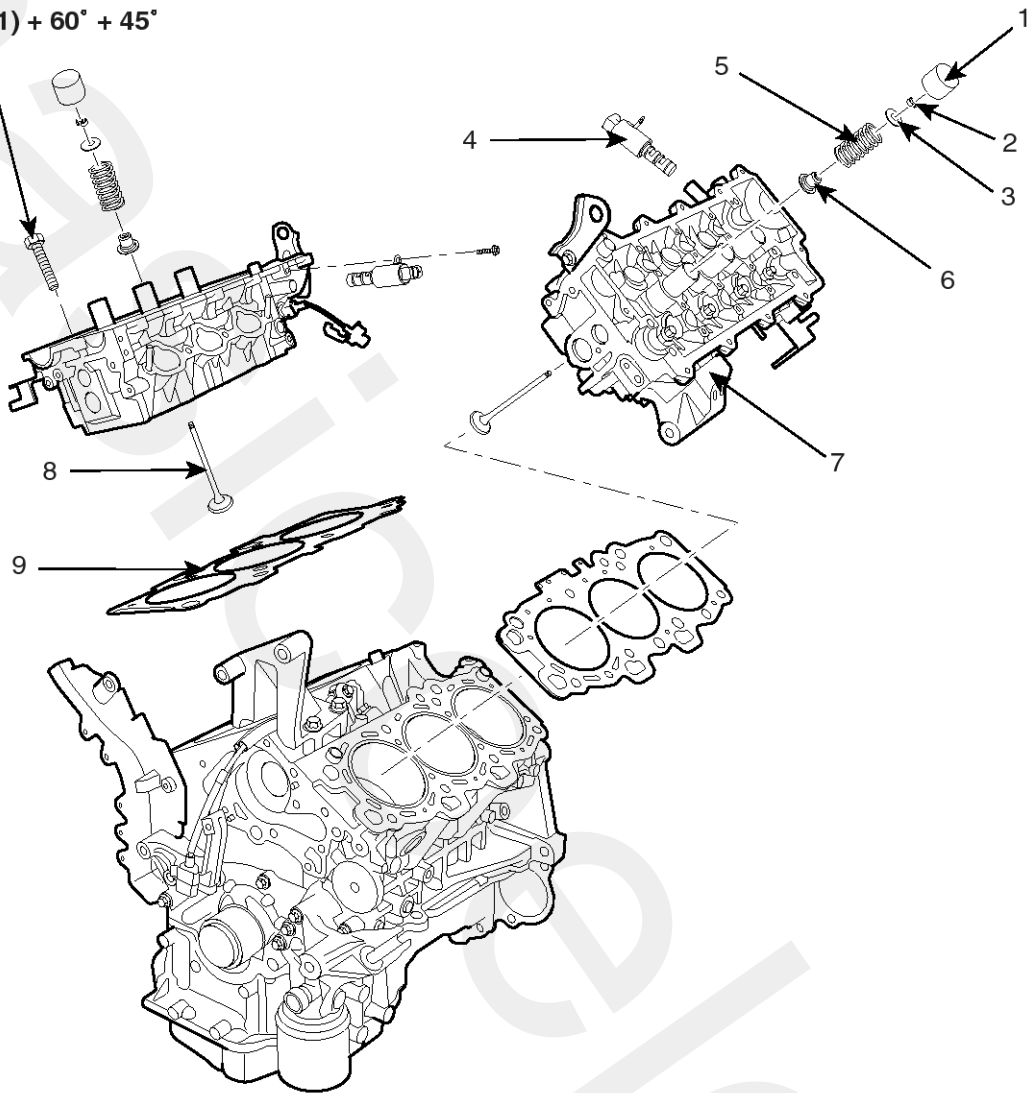

## TORQUE : N.m (kgf.m, lb-ft)

- |                                  |                         |
|----------------------------------|-------------------------|
| 1. MLA(Mechanical Lash Adjuster) | 6. Valve stem seal      |
| 2. Retainer lock                 | 7. Cylinder head        |
| 3. Retainer                      | 8. Valve                |
| 4. OCV(Oil Control Valve)        | 9. Cylinder head gasket |
| 5. Valve spring                  |                         |

## REMOVAL

## ⚠ CAUTION

- Use fender covers to avoid damaging painted surfaces.
- To avoid damaging the cylinder head, wait until the engine coolant temperature drops below normal temperature before removing it.
- When handling a metal gasket, take care not to fold the gasket or damage the contact surface of the gasket.
- To avoid damage, unplug the wiring connectors carefully while holding the connector portion.

## 📌 NOTICE

- Mark all wiring and hoses to avoid misconnection.
  - Turn the crankshaft pulley so that the No. 1 piston is at top dead center.
1. Remove the air duct and the battery(A) after disconnecting the terminals(B) from the battery.

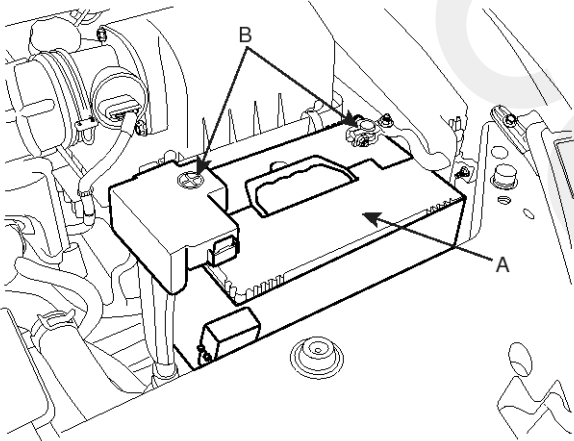

SVQM16001L

2. Remove the engine cover.
3. Remove the intake air hose and air cleaner assembly.
  - 1) Disconnect the MAF connector(A).
  - 2) Disconnect the breather hose(B) from air cleaner hose.
  - 3) Remove the intake air hose and air cleaner assembly(C).

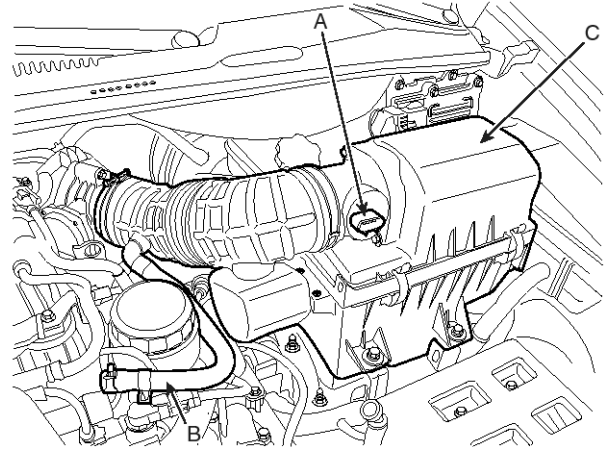

BCKG002A

4. Remove the upper radiator hose(A) and lower radiator hose(B).

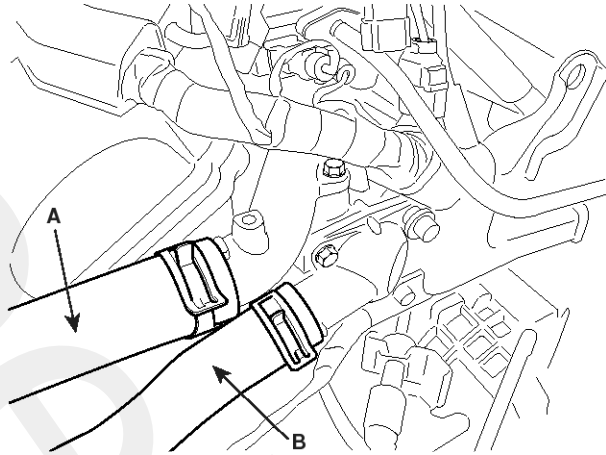

LDLG008A

5. Remove the fuel inlet hose(A) from the delivery pipe.

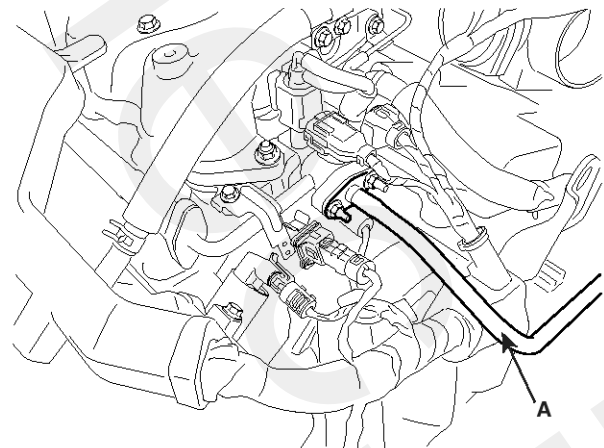

LDLG062A

6. Disconnect the engine wiring harness connectors.

- 1) Disconnect the No.1/No.2 knock sensor connectors(A,B), the oil pressure switch connector(C), the ignition coil harness(D) and the No.1 VIS(Variable Induction System) connector(E).

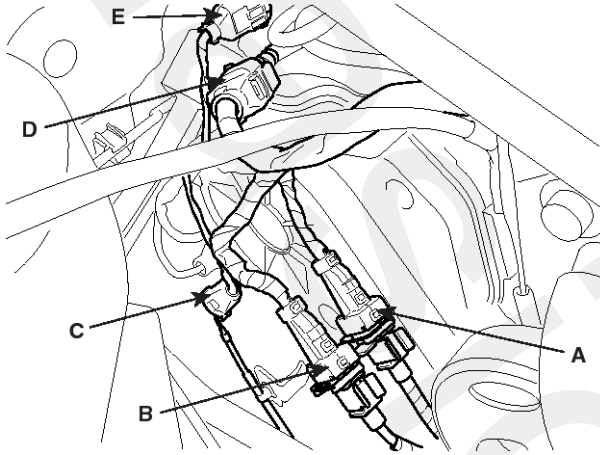

LDLG005A

- 2) Disconnect the bank 1 front/rear O2 sensor connectors(A).

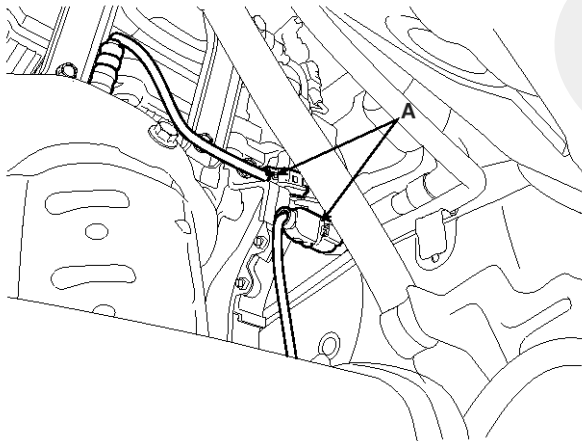

KCBF160A

- 3) Disconnect the injection connectors(A,B,C), the ground lines(D), the condenser connector(E) and the Ignition coil connectors(F).

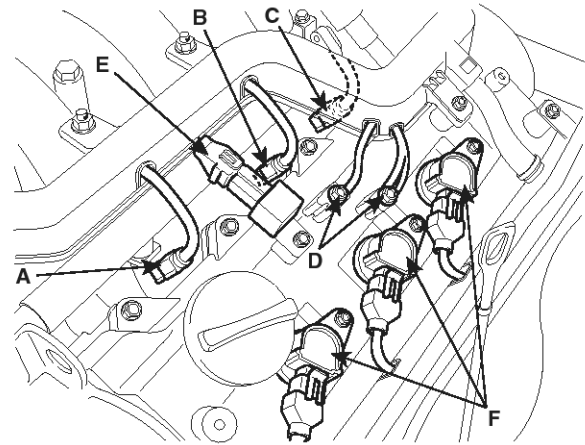

LDLG060A

- 4) Disconnect the injection harness connector(A), the No.2 VIS(Variable Induction System) connector(B), the No.1/No.2 OCV(Oil Control Valve) connectors(C,D) and the OTS(Oil Temperature Sensor) connector(E).

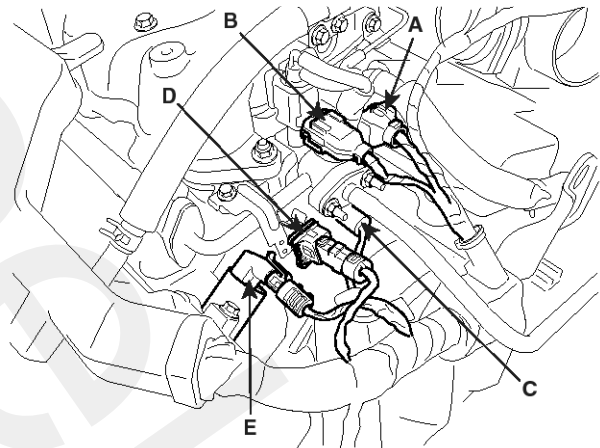

LDLG006A

- 5) Disconnect the MAPS(Manifold Absolute Pressure Sensor) connector(A), the ETC(Electronic Throttle Control) connector(B) and the PCSV(Purge Control Solenoid Valve) connector(C).



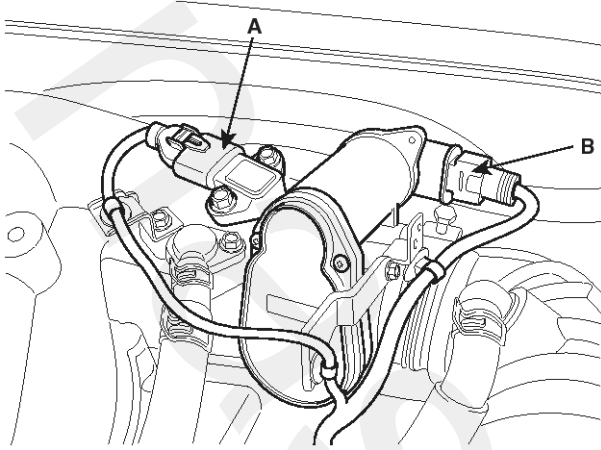

LDLG034A

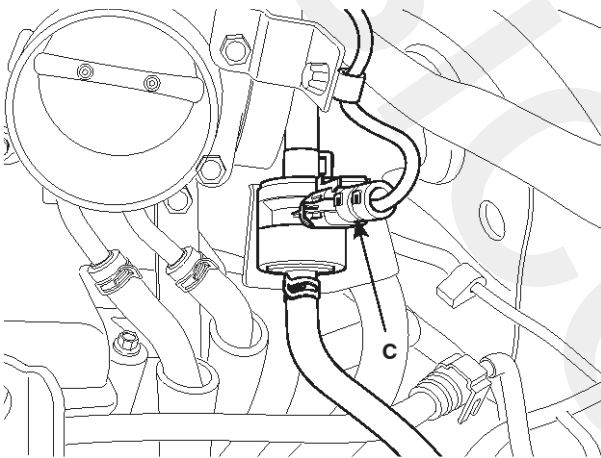

LDLG035A

- 6) Disconnect the generator connector(A) and the air conditioning compressor connector(B).

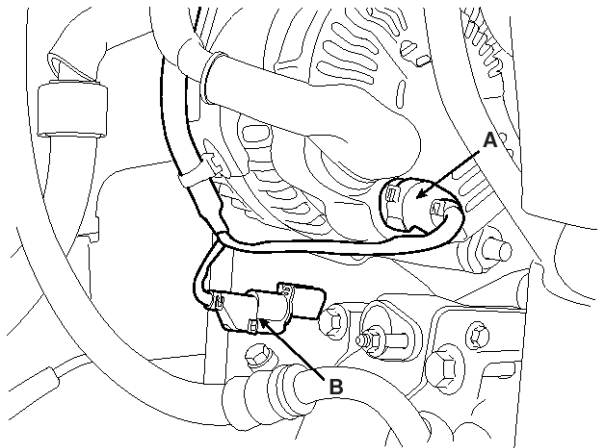

KCBF151A

- 7) Disconnect the bank 2 CMP sensor connector(A) and the ECT(Engine Coolant Temperature) sensor connector(B).

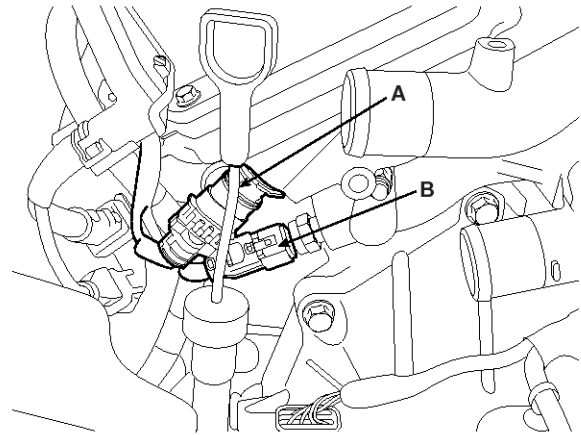

KCBF155A

- 8) Disconnect the bank 2 front/rear O2 sensor connectors(A,B) and the CKP sensor connector(C).

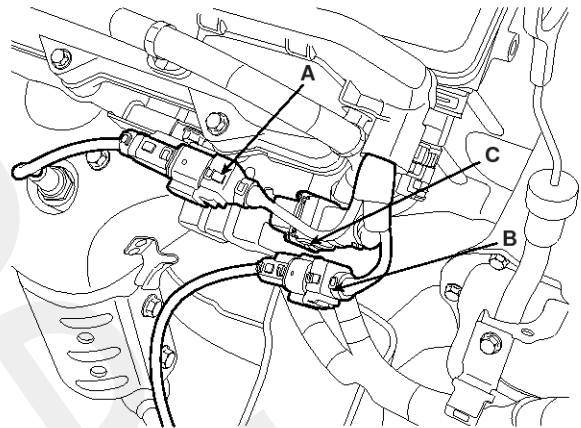

KCBF154A

- 9) Disconnect the bank 1 CMP sensor connector(A).

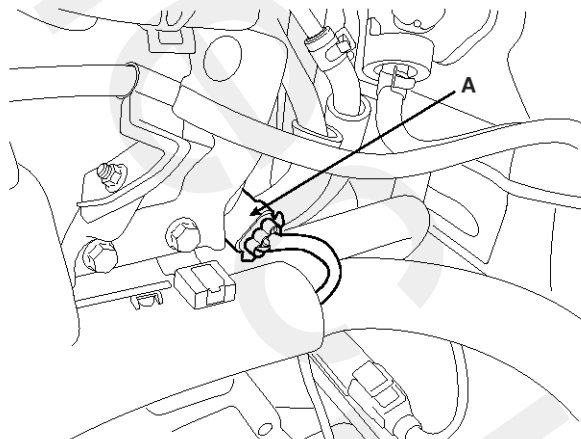

KCBF152A

7. Remove the PCV(Pulse Control Valve) hose(A).

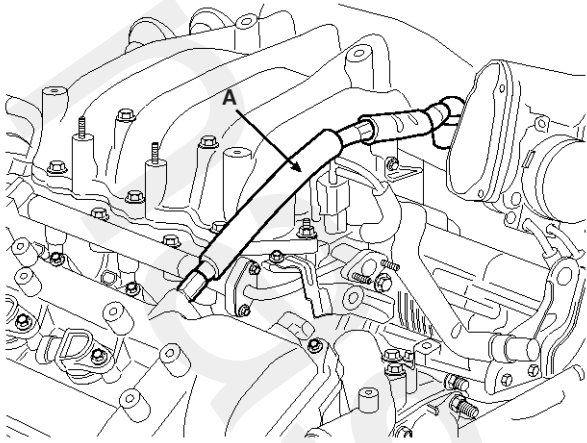

KCBF180A

8. Disconnect the brake vacuum hose(A).

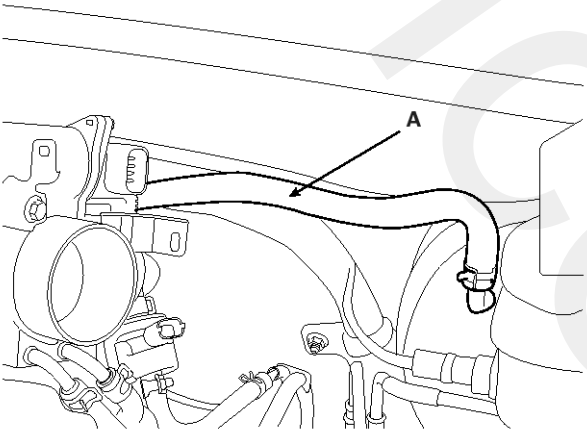

LDLG036A

9. Remove the heater hoses.

10. Remove the drive belt(A).

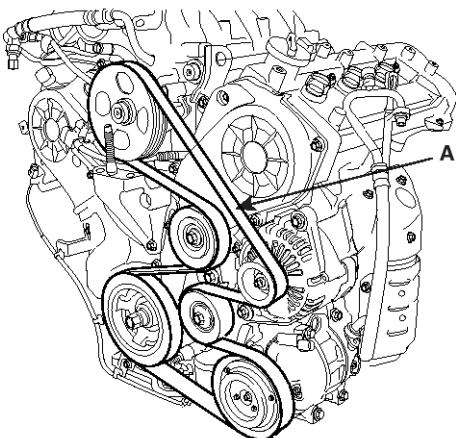

KCBF105A

11. Remove the power steering pump.(Refer to 'ST' group).

12. Remove the exhaust manifold assembly.(Refer to 'Intake and exhaust system').

13. Remove the intake manifold assembly.(Refer to 'Intake and exhaust system').

14. Remove the timing belt.(Refer to 'Timing system').

15. Remove the ignition coils.

16. Remove the water temp. control assembly.

17. Remove the cylinder head cover(A).

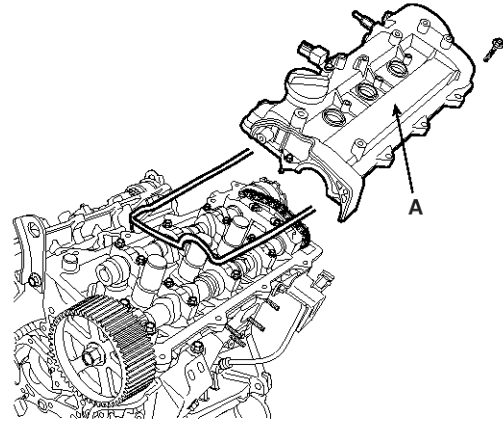

KCBF177A

18. Remove the camshaft bearing cap(A).

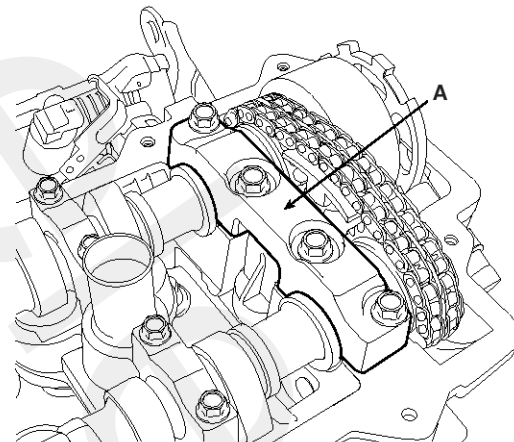

KCBF167A

19. Remove the timing chain tensioner(A).

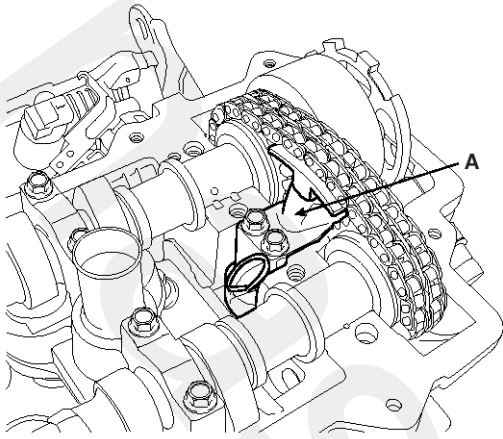

KCBF168A

20. Remove the camshaft.

21. Remove the bank 2 timing belt rear cover(A).

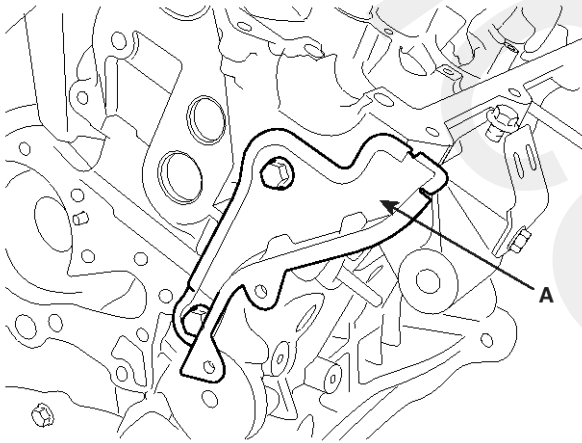

KCBF170A

22. Remove the bank 1 timing belt rear cover(A).

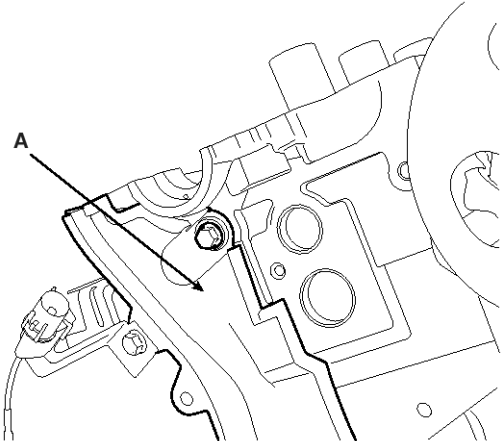

KCBF171A

23. Remove the CKP sensor connector bracket(A).

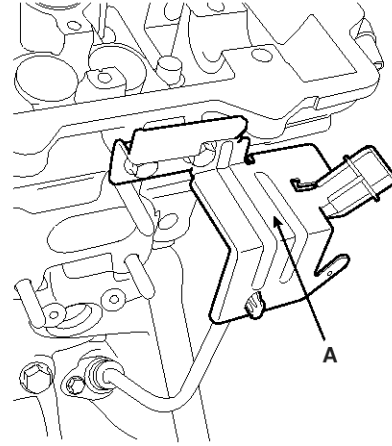

KCBF172A

24. Remove the cylinder head assembly.

1) Remove the bolts in 2~3 steps as following orders.

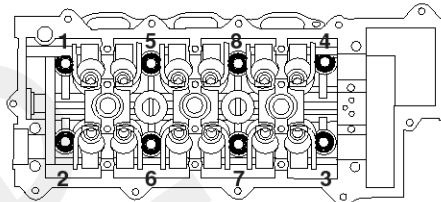
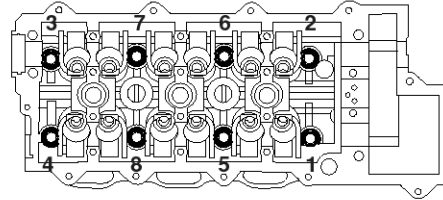

KCBF176A

**CAUTION**

If the bolts are not removed as the order, the deformation of the head assembly can be occurred.

2) Put the cylinder head assembly on a wooden block after removal from the cylinder block.

**CAUTION**

Ensure that the surface between the cylinder head and the block is not damaged.

## REPLACEMENT

### Valve guide

1. Using the SST(09221-3F100A), remove the valve guide from the downside of the cylinder head assembly.

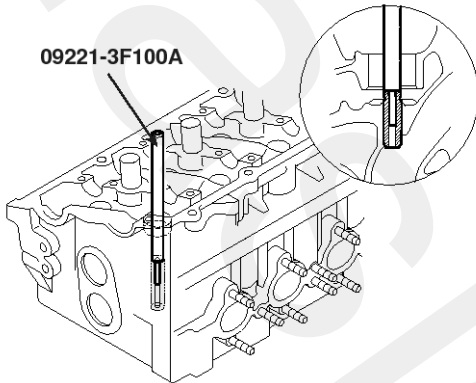

EDKD900A

2. Reprocess the valve guide hole for the oversized valve guide newly installed.
3. Using the SST(09221-3F100A/B), insert the valve guide in the upside of the cylinder head assembly. Be aware of the difference in length between the intake and the exhaust valve guides.

### Specification

Intake valve guide: 45.8 ~ 46.2mm(1.8031 ~ 1.8189in.)

Exhaust valve guide: 46.8 ~ 47.2mm(1.8425 ~ 1.8583in.)

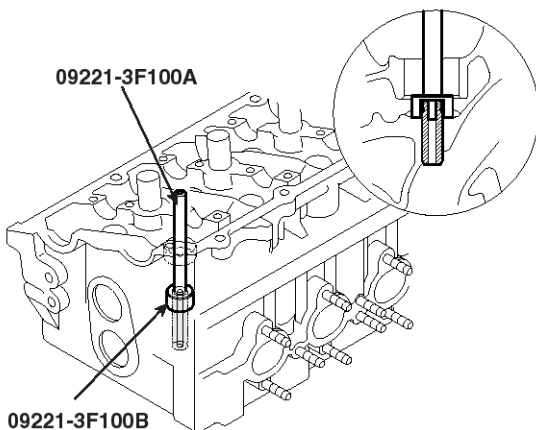

EDKD900B

4. After installing the valve guides, insert new valves and check the clearance between the valve stems and the valve guides.
5. After replacing the valve guides, check if they are properly installed with the valve seats. Reprocess valve seats if necessary.

## DISASSEMBLY

### NOTICE

Identify *MLA*(Mechanical Lash Adjuster), valves and valve springs as they are removed so that each item can be reinstalled in its original position.

1. Remove *MLA*(Mechanical Lash Adjuster)s(A).

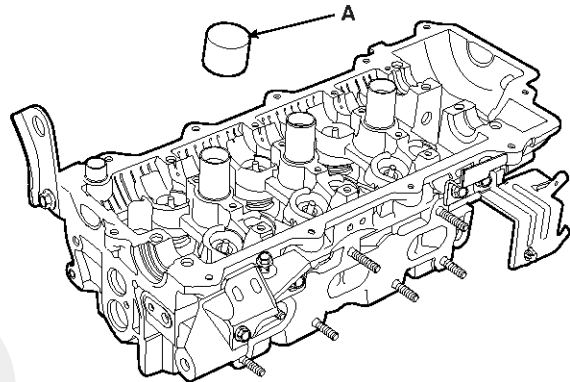

KCBF173D

2. Remove valves.

- 1) Using SST(09222-3K000, 09222-3C300), compress the valve spring and remove retainer lock.

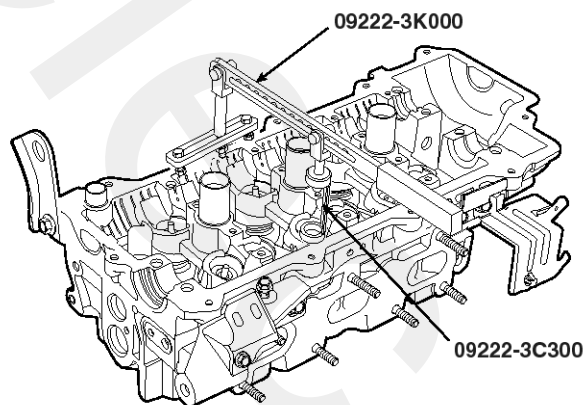

KCBF173C

- 2) Remove the spring retainer.
- 3) Remove the valve spring.
- 4) Remove the valve.

5) Using SST(09222-29000), remove the valve stem seal.

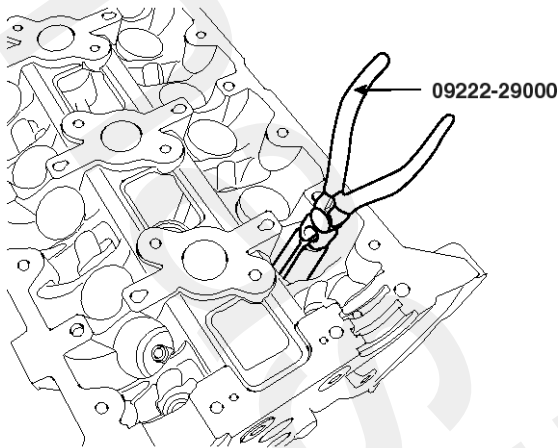

KDRF234A

### NOTICE

Do not reuse the removed valve stem seals.

3. Remove OCV(Oil Control Valve)(A).

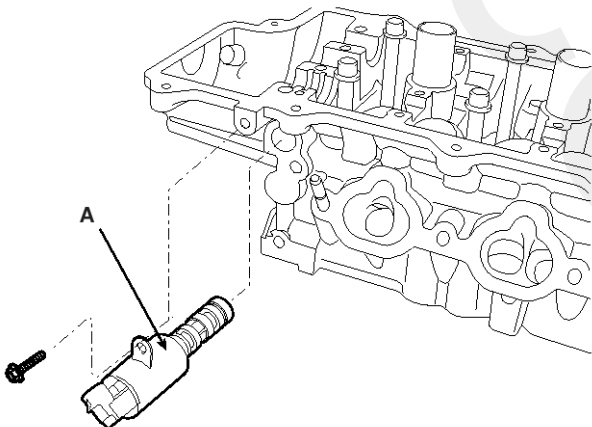

KCBF166A

### INSPECTION CYLINDER HEAD

1. Inspect for flatness.

Using a precision straight edge and feeler gauge, measure the surface contacting cylinder block and the manifolds for warpage.

#### Flatness of cylinder head gasket surface

Standard : 0.03mm(0.0012in.) or less

#### Flatness of manifold gasket surface

Standard : 0.15mm(0.0059in.) or less

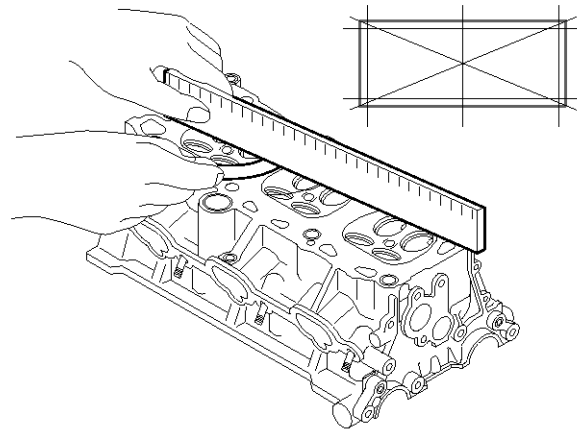

EDQF160A

2. Inspect for cracks.

Check the combustion chamber, intake ports, exhaust ports and cylinder block surface for cracks. If cracked, replace the cylinder head.

### VALVE AND VALVE SPRING

1. Inspect valve stems and valve guides.

1) Using a caliper gauge, measure the inside diameter of the valve guide.

#### Valve guide inside diameter

Intake / Exhaust : 6.000 ~ 6.015mm (2.2362 ~ 2.2368in.)

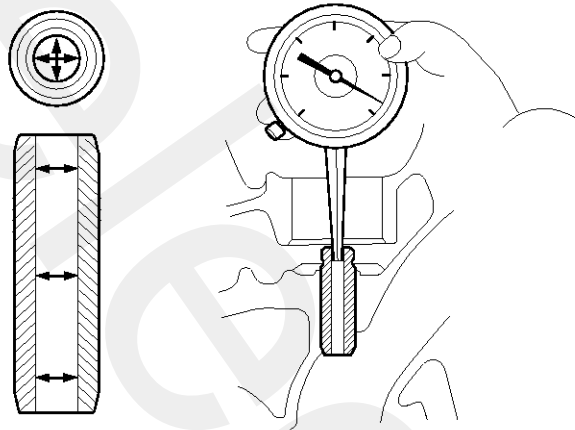

ECBF034A

2) Using a micrometer, measure the outer diameter of the valve stem.

#### Valve stem outer diameter

Intake : 5.585 ~ 5.980mm (0.2348 ~ 0.2354in.)

Exhaust : 5.950 ~ 5.955mm (0.2343 ~ 0.2348in.)

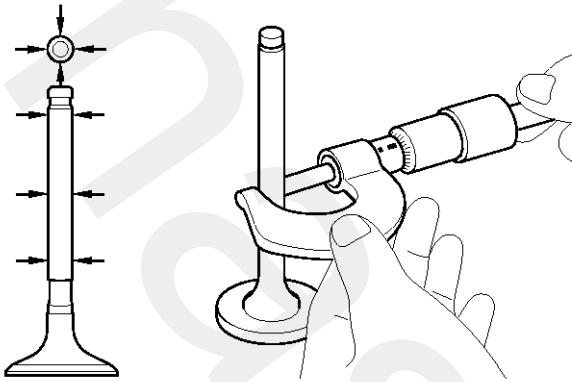

KCRF227A

- 3) Calculate the clearance between the valve guides and the stems by difference between the valve stem measured diameter and the valve guide measured inside diameter.

### Valve stem-to-guide clearance

[Standard]

Intake : 0.020 ~ 0.050mm (0.0008 ~ 0.0020in.)

Exhaust : 0.035 ~ 0.065mm (0.0014 ~ 0.0026in.)

[Limit]

Intake : 0.10mm (0.0039in.) or less

Exhaust : 0.13mm (0.0051in.) or less

### 2. Inspect valves.

- 1) Check the valve face angle.
- 2) Check that the surface of the valve for wear.  
If the valve face is worn, replace the valve.
- 3) Check the valve head margin thickness.  
If the margin thickness is less than the specification, replace the valve.

### Specification

Intake : 1.0mm(0.0394in.)

Exhaust : 1.3mm(0.0512in.)

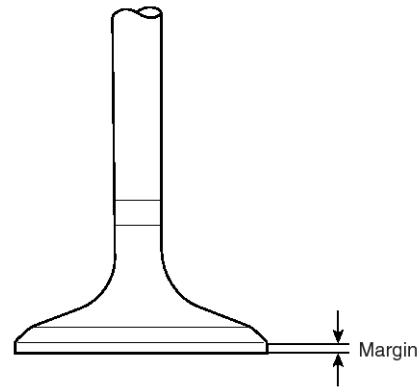

ECKD221A

- 4) Check the valve length.

### Length

Intake : 110.1mm(4.3346in)

Exhaust : 111.1mm(4.3740in)

- 5) Check the surface of the valve stem tip for wear.  
If the valve stem tip is worn, replace the valve.
3. Inspect valve seats
    - 1) Check the valve seat for evidence of overheating or improper contact with the valve face.  
If the valve seat is worn, replace cylinder head.
    - 2) Before reconditioning the seat, check the valve guide for wear. If the valve guide is worn, replace the valve guide first.
    - 3) Recondition the valve seat with a valve seat grinder or cutter. The valve seat contact width should be within specifications and centered on the valve face.
  4. Inspect valve springs.
    - 1) Using a steel square, measure the out-of-square of the valve spring.
    - 2) Using vernier calipers, measure the free length of the valve spring.

### Valve spring

[Standard]

Free height : 46.8mm (1.8425in.)

Out-of-square : 1.5° or less

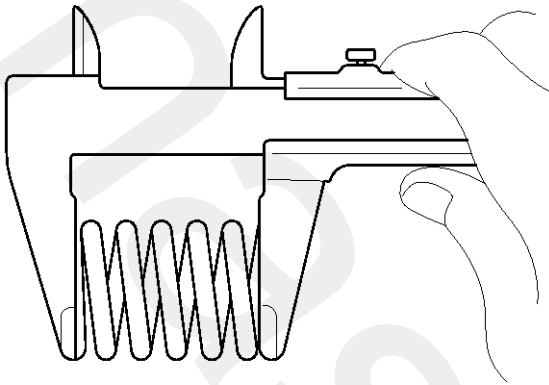

KCRF205A

**MLA(Mechanical Lash Adjuster)**

1. Inspect MLA.

Using a micrometer, measure the MLA outside diameter.

**MLA O.D.**

Intake/Exhaust : 29.964 ~ 29.980mm(1.1797 ~ 1.1803in.)

2. Using a caliper gauge, measure MLA tappet bore inner diameter of cylinder head.

**Tappet bore I.D.**

Intake/Exhaust : 30.000 ~ 30.025mm(1.1811 ~ 1.1821in.)

3. Calculate the clearance by subtracting MLA outside diameter measurement from tappet bore inside diameter measurement.

**MLA to tappet bore clearance**

[Standard]

Intake/Exhaust : 0.020 ~ 0.061mm(0.0008 ~ 0.0024in.)

[Limit]

Intake/Exhaust : 0.07mm(0.0027in.) or less

**CAMSHAFT**

1. Inspect cam lobes.

Using a micrometer, measure the cam lobe height.

**Cam height**

[Standard value]

Intake : 44.5mm (1.7520in.)

Exhaust : 44.5mm (1.7520in.)

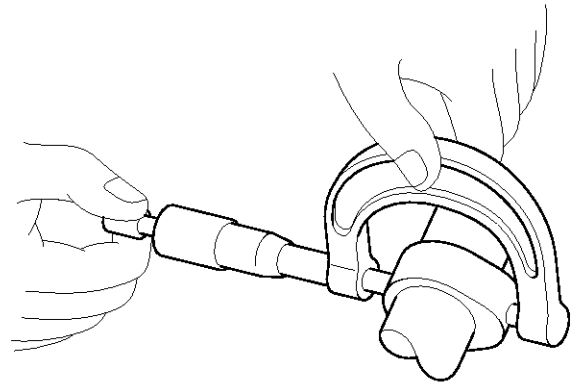

KCRF206A

If the cam lobe height is less than standard, replace the camshaft.

2. Check the cam lobe surface for wear or damage. If necessary, replace it.
3. Inspect camshaft journal clearance.
  - 1) Clean the bearing caps and camshaft journals.
  - 2) Place the camshafts on the cylinder head.
  - 3) Lay a strip of plastigage across each of the camshaft journals.

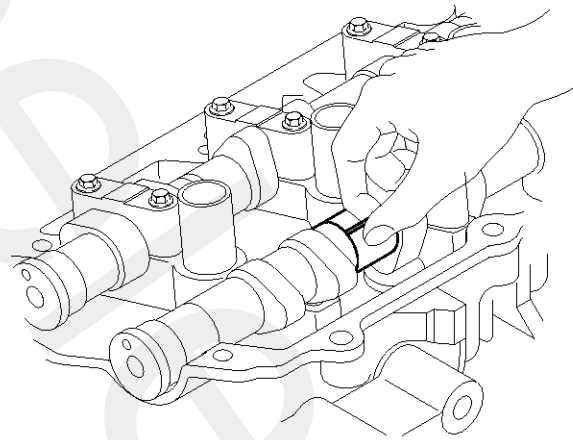

KCRF207A

- 4) Install the bearing caps with the tightening torque.

**CAUTION**

**Do not turn the camshaft.**

- 5) Remove the bearing caps.
- 6) Measure the plastigage at its widest point.

**Bearing oil clearance**

[Standard value]

Intake : 0.020 ~ 0.057mm (0.0008 ~ 0.0022in.)

Exhaust : 0.020 ~ 0.057mm (0.0008 ~ 0.0022in.)

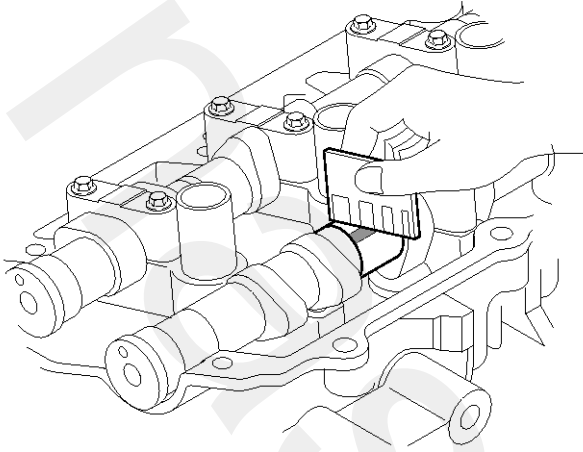

KCRF208A

If the oil clearance is greater than the maximum, replace the camshaft. If necessary, replace the cylinder head.

- 7) Completely remove the plastigage.
  - 8) Remove the camshafts.
4. Inspect camshaft end play.
- 1) Install the camshafts.
  - 2) Using a dial indicator, measure the end play while moving the camshaft back and forth.

### Camshaft end play

[Standard value] : 0.05 ~ 0.15mm(0.0020 ~ 0.0059in.)

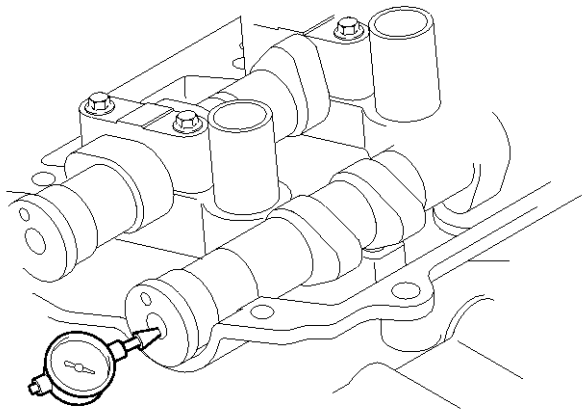

KCBF173E

If the end play is greater than the maximum, replace the camshaft. If necessary, replace the cylinder head.

- 3) Remove the camshafts.

### CVVT ASSEMBLY

1. Inspect CVVT assembly.
  - 1) Fix the CVVT assembly with a vice. Ensure that the cam lobe and journal is not damaged.

- 2) Check that the CVVT assembly will not turn. It should not be turned.
- 3) Apply vinyl tape to the retard hole except the one(A) indicated by the arrow in the illustration.

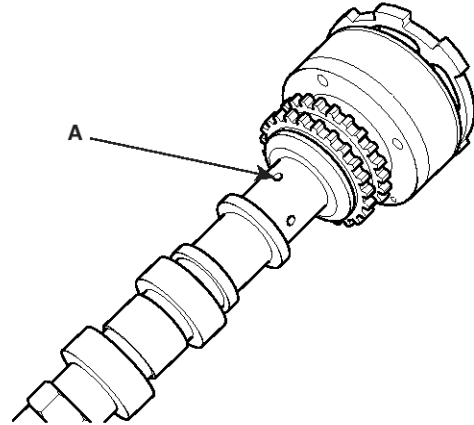

KCBF188A

- 4) Wind tape around the tip of the air gun and apply air of approx. 150kpa(1.5kgf/cm<sup>2</sup>, 21psi) to the port of the camshaft.  
(Perform this in order to release the lock pin for the maximum delay angle locking.)

### NOTICE

*When the oil splashes, wipe it off with a shop rag.*

- 5) After the lock pin released, the CVVT assembly can turned in advanced direction.  
If the air applied is leaked much, the lock pin can not be released.
- 6) Except the position where the lock pin meets at the maximum delay angle, let the CVVT assembly turn back and forth and check the movable range and that there is no resistance to movement.

Standard: Movable smoothly in the range about 60°

- 7) Turn the CVVT assembly with your hand in retard direction and lock it at the maximum delay angle position.



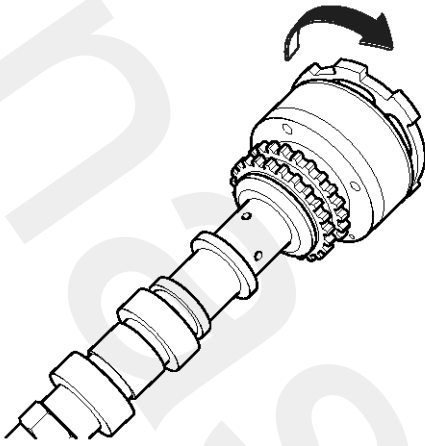

KCBF188B

**REASSEMBLY****NOTICE**

- Thoroughly clean all parts to be assembled.
- Before installing the parts, apply fresh engine oil to all sliding and rotating surfaces.
- Replace oil seals with new ones.

## 1. Install valves.

- 1) Using SST(09222-22001), push in a new valve stem seal with applying engine oil.

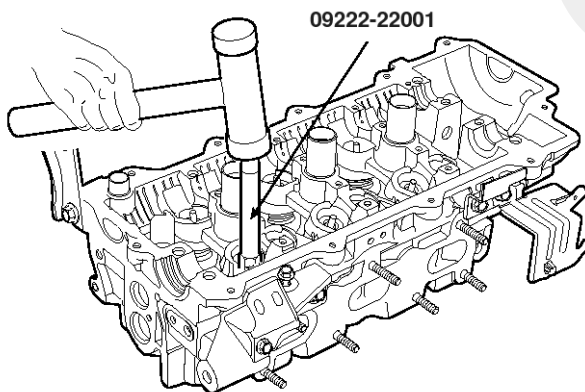

KCBF173B

**NOTICE**

- Do not reuse old valve stem seals.  
Incorrect installation of the seal could result in oil leakage past the valve guides.
  - Reassemble the valve stem seals
- 2) After applying engine oil on the outer surface of each valve stem, insert the valve in the valve guide.

Install the valve, valve spring and spring retainer.

**NOTICE**

When installing valve springs, the side coated with enamel should face toward the valve spring retainer

- 3) Using the SST(09222 - 3K000, 09222-3C300), compress the springs and install the retainer locks. After installing the valves, ensure that the retainer locks are correctly in place before releasing the valve spring compressor.

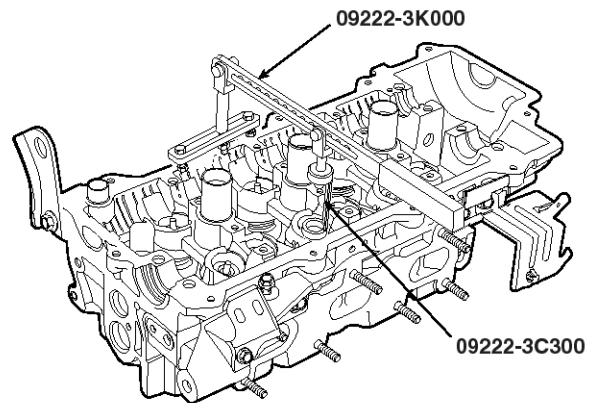

KCBF173C

- 4) Lightly tap the end of each valve stem two or three times with the wooden handle of a hammer to ensure proper seating of the valve and retainer lock.
2. Install MLAs with engine oil applied on its surface.  
Check that the MLA rotates smoothly by hand.

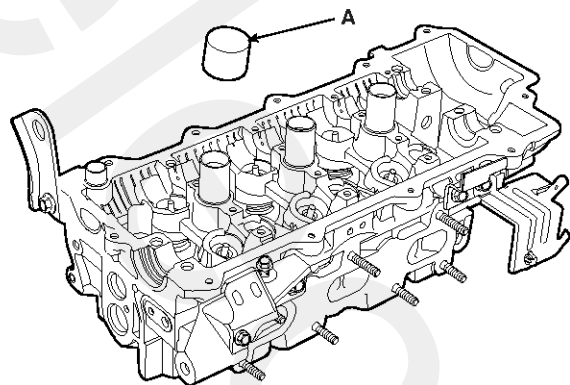

KCBF173D

**NOTICE**

MLA should be reinstalled in its original position.

3. Install OCV(Oil Control Valve)(A).

### Tightening torque

7.8 ~ 9.8Nm(0.8 ~ 1.0kgf.m, 5.8 ~ 7.2lb-ft)

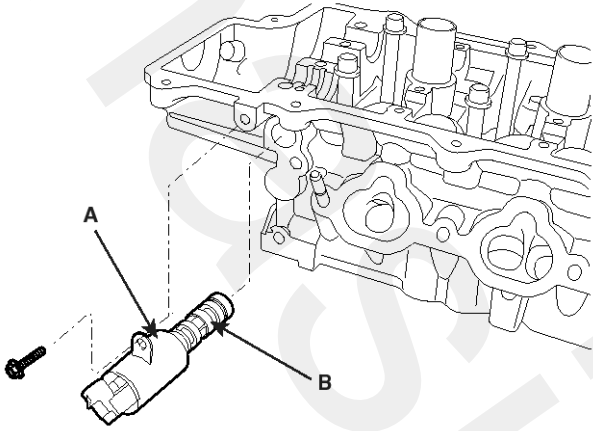

KCBF166B

### NOTICE

- To install OCV with gray colored connector into RH bank.
- To install OCV with black colored connector into LH bank.

### CAUTION

- Do not reuse the OCV when dropped.
- Keep clean the OCV.
- Do not hold the OCV sleeve during servicing.
- When the OCV is installed on the engine, do not move the engine while holding the OCV yoke.
- If there is dust on the filter(B) of the OCV, clean it all.

## INSTALLATION

### NOTICE

- Thoroughly clean all parts to be assembled.
- Always use a new head and manifold gasket.
- The cylinder head gasket is a metal gasket. Take care not to bend it.
- Rotate the crankshaft to set the No.1 cylinder piston at TDC.

1. After putting the cylinder head gasket on the cylinder block, install the cylinder head.

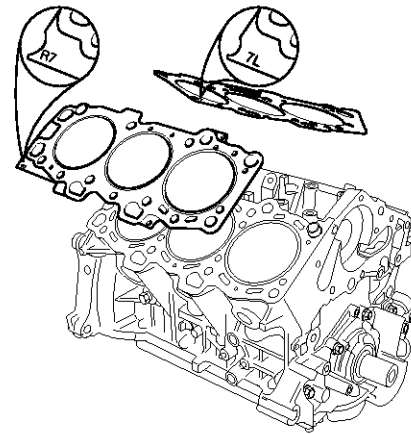

KCBF191A

### CAUTION

Ensure the LH/RH classification of the cylinder head gasket when installing.

2. Tighten the cylinder head bolts with the plain washers in several steps as following order.

### NOTICE

- In assembling washers, the marked surface should face upward.
- In installing the cylinder head bolts, apply engine oil on the thread of the bolts and the surface of the washers.

### CAUTION

Always use new cylinder head bolts.

### Tightening torque

22.6~26.5Nm (2.3~2.7kgf.m, 16.6~19.5lb-ft) + 58~62° + 43~47°

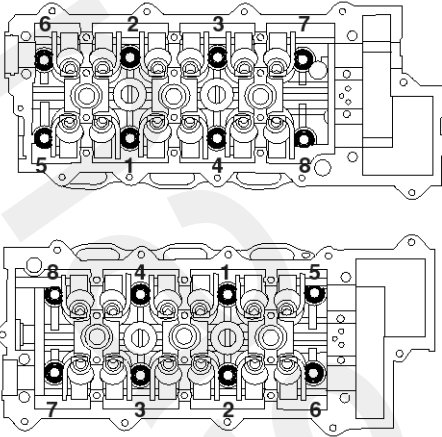

KCBF176B

**NOTICE**

Using the SST(09221-4A000), tighten the bolts which need to be tightened with the angular tightening method.

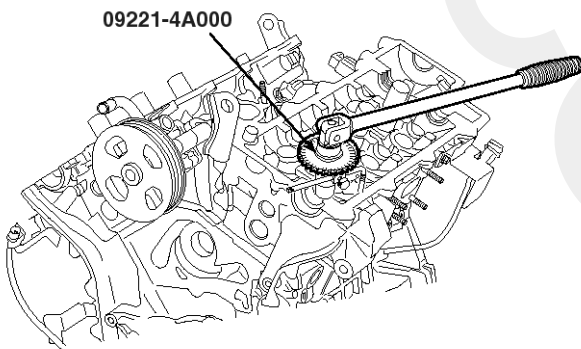

LDLG063A

3. Install the CVVT assembly and camshaft chain sprocket with the dowel pin in the CVVT installed to the intake camshaft. Ensure that the pin will not be installed in the hole for oil feeding.

**Tightening torque**

66.7~78.5Nm(6.8~8.0kgf.m, 49.2~57.9lb-ft)

**NOTICE**

After tightening the CVVT bolts, rotate the CVVT assembly housing counterclockwise by hand to seat the lock pin in the CVVT assembly in good position.

**CAUTION**

Fix the hexagonal part of the camshaft in a vice when tightening the CVVT bolts. Do not fix the CVVT housing or sprocket in a vice.

4. Install the camshaft in the cylinder head assembly.

- 1) Align the timing marks of the intake and exhaust camshaft chain sprockets and the timing chain.

**CAUTION**

Both timing marks should face upward for reassembly.

- 2) Install the intake and exhaust camshafts on the cylinder head with the timing marks aligned.

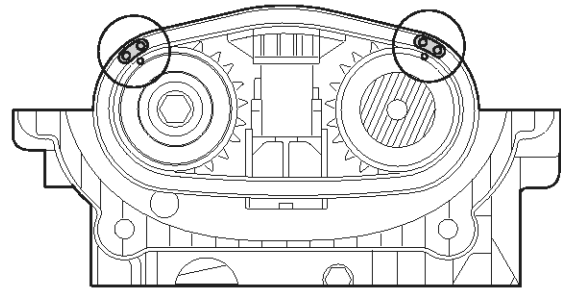
**LH camshaft chain timing mark**

SVQEM9032D

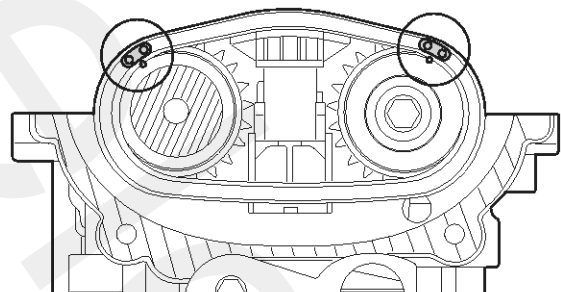
**RH camshaft chain timing mark**

SVQEM8033D

5. Install the timing chain tensioner.
  - 1) Insert the set pin by pressing the timing chain tensioner.
  - 2) Install the chain tensioner(A) in the cylinder head assembly.

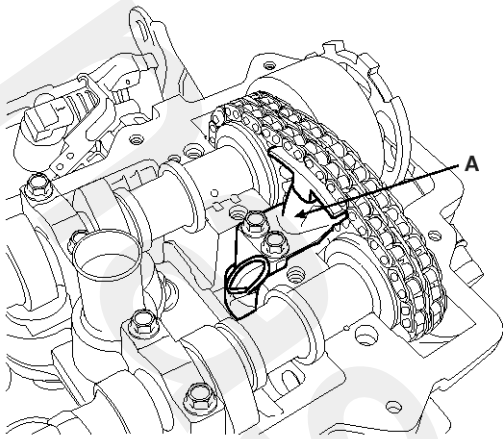

KCBF168A

6. Install the camshaft bearing caps.

### Tightening torque

Bearing cap bolt(A: 6×38) - 10.8~12.7Nm(1.1~1.3kgf.m, 8.0~9.4lb-ft)

Bearing cap bolt(B: 8×38) - 20.6~22.5Nm(2.1~2.6kgf.m, 15.2~18.8lb-ft)

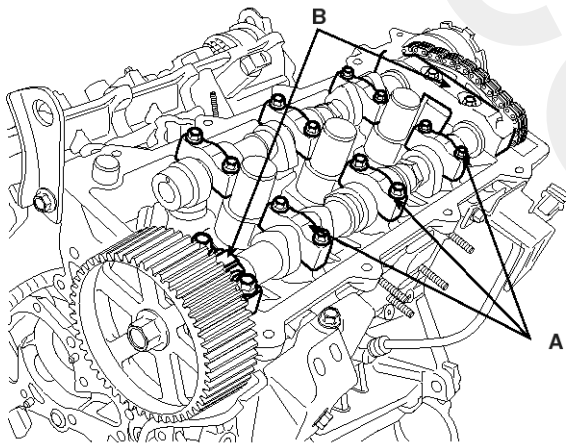

KCBF169A

### NOTICE

When installing the bearing caps, check the marks on them as shown below and install them in its proper position.

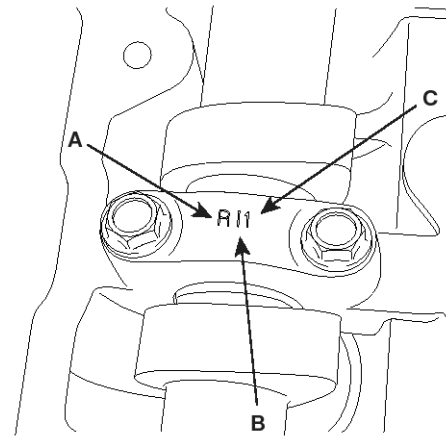

KDRF228A

A(LH/RH HEAD): L(LH), R(RH)

B(Intake/Exhaust): I(Intake), E(Exhaust)

C(Cap no.): 1,2,3

### CAUTION

When installing the bearing caps, turn the crankshaft to place a piston in the middle of the block because linterference between valves and pistons can occur.

7. Using the SST(09214-21000), install the camshaft oil seal.

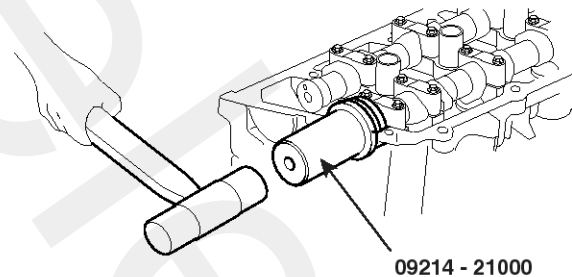

09214 - 21000

KCBF190A

### NOTICE

- Befor installing, apply engine oil.
- The camshaft cap surface should adhere to the cylinder head assembly.
- Do not press an eccentric load.

8. Install the camshaft sprocket.

- 1) Hold the hexagonal head wrench portion of the camshaft with a vise, and install the bolt.

### Tightening torque

88.3 ~ 107.9Nm (9.0 ~ 11.0kgf.m, 65.1 ~ 79.6lb-ft)

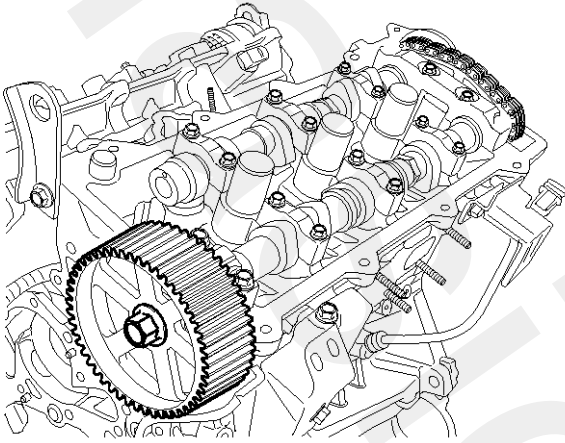

SVQEM8038D

- 2) In case that the camshaft is replaced with new one, inspect the valve clearances and then install appropriate MLA tappet. (Refer to Valve clearance inspection and adjustment)

### CAUTION

To prevent the valve from interfering with the piston, rotate the crankshaft sprocket at 3 pitches counterclockwise from the No.1 cylinder piston at TDC position before inspecting the valve clearances.

9. Install the CKP sensor connector bracket(A).

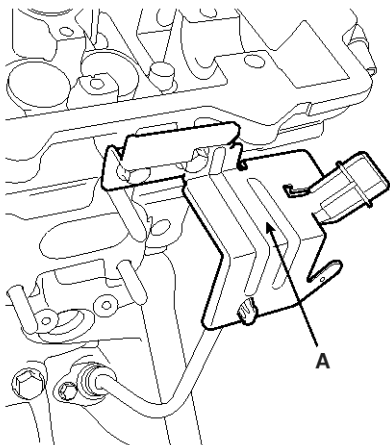

KCBF172A

10. Install the bank 1 timing belt rear cover(A).

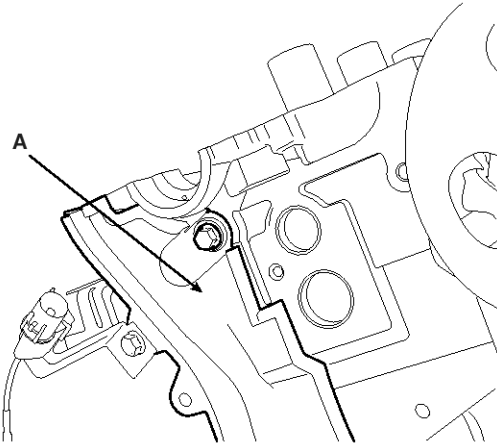

KCBF171A

11. Install the bank 2 timing belt rear cover(A).

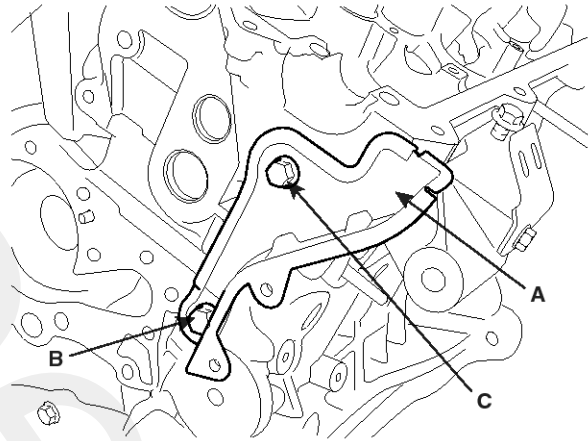

KCBF170B

### NOTICE

The length of the bolt(B) is longer than that of the bolt(C).

12. Install the cylinder head cover.

- 1) Remove oil, dust or sealant on the upper surface of the cylinder before assembling cylinder head cover.
- 2) Assemble the cylinder head cover in five minutes after applying liquid gasket(LOCTITE 5900) on the camshaft cap and packing part.

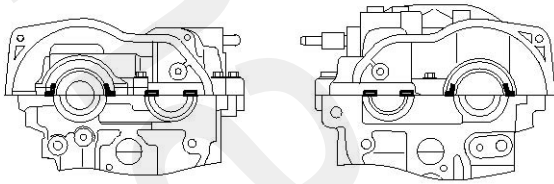

KCBF174A

- 3) Tighten the cylinder head cover bolts as following order(A).

### Tightening torque

7.8~9.8Nm(0.8~1.0kgf.m, 5.8~7.2lb-ft)

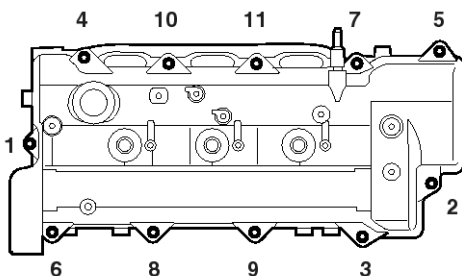
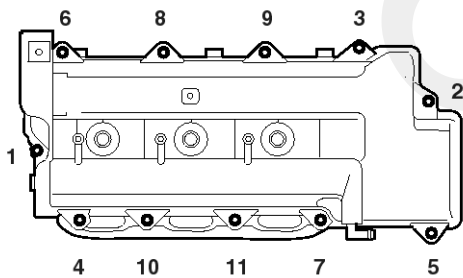

KCBF175A

### NOTICE

- Do not start engine for thirty minites after assembling the cylinder head cover.
- Do not reuse the cylinder head cover gasket.

13. Install the timing belt.

- 1) Align the timing marks of the LH/RH camshaft sprockets.

### CAUTION

To prevent the valve from interfering with the piston, rotate the crankshaft sprocket at 3 pitches counterclockwise from the No.1

cylinder piston at TDC position before aligning the timing marks of the camshaft sprockets.

- 2) After aligning the timing marks of the camshaft sprockets, rotate the crankshaft sprocket at 3 pitches clockwise then align the timing mark of the crankshaft sprocket to set the crankshaft to the No.1 cylinder piston at TDC position.
- 3) Install the timing belt. (Refer to Timing system)
14. Install the water temp. control assembly.
15. Install the intake manifold assembly.
16. Install the exhaust manifold assembly.
17. Install the power steering pump.(Refer to 'ST' group).
18. Install the drive belt(A).

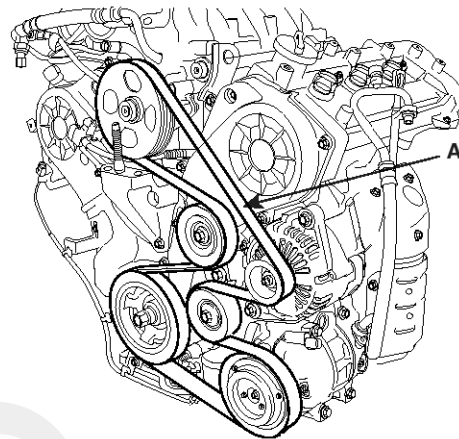

KCBF105A

19. Install the heater hose.
20. Connect the brake vaccume hose(A).

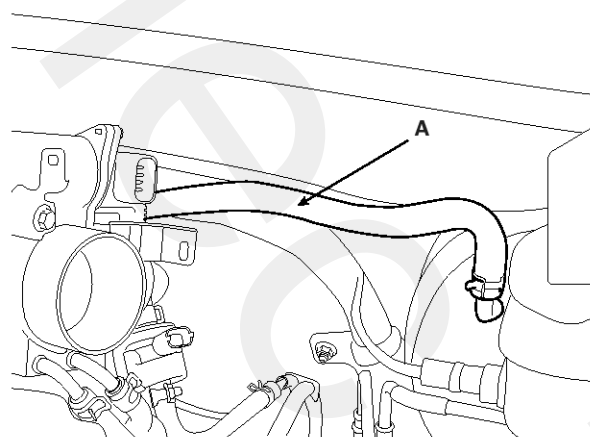

LDLG036A

21. Install the PCV(Pulge Control Valve) hose(A).

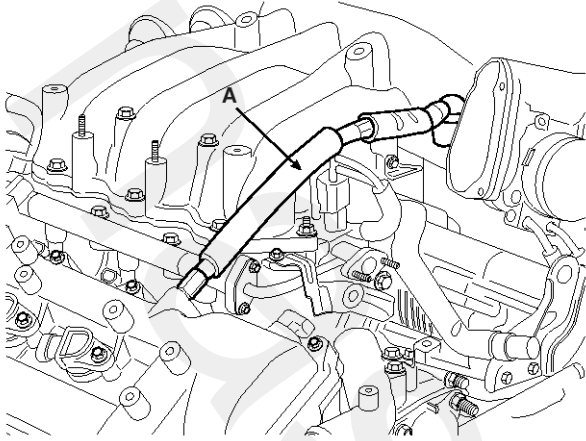

KCBF180A

22. Connect the engine wiring harness connectors.

- 1) Connect the bank 1 CMP sensor connector(A).

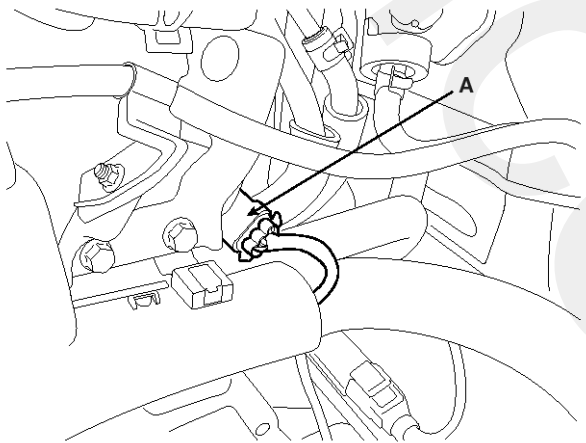

KCBF152A

- 2) Connect the bank 2 front/rear O2 sensor connectors(A,B) and the CKP sensor connector(C).

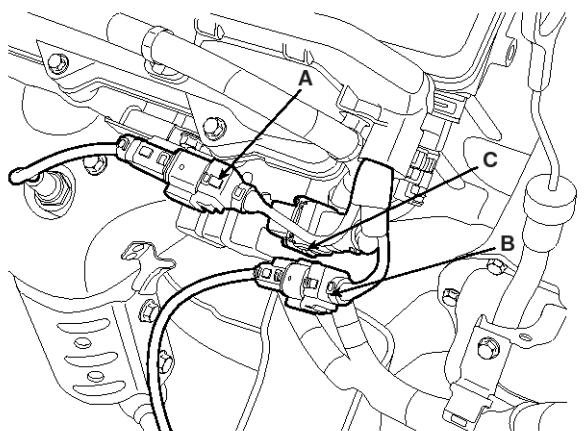

KCBF154A

- 3) Connect the bank 2 CMP sensor connector(A) and the WTS(Water Temperature Sensor) connector(B).

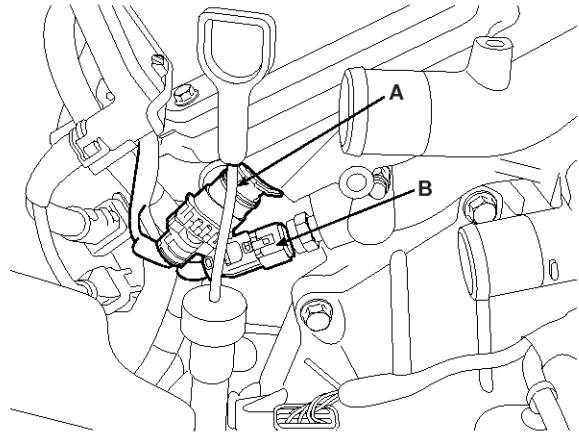

KCBF155A

- 4) Connect the generator connector(A) and the air conditioning compressor connector(B).

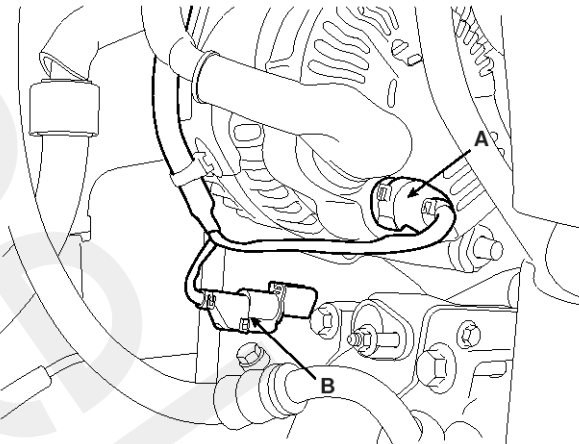

KCBF151A

- 5) Connect the MAPS(Manifold Absolute Pressure Sensor) connector(A), the ETC(Electronic Throttle Control) connector(B) and the PCSV(Purge Control Solenoid Valve) connector(C).

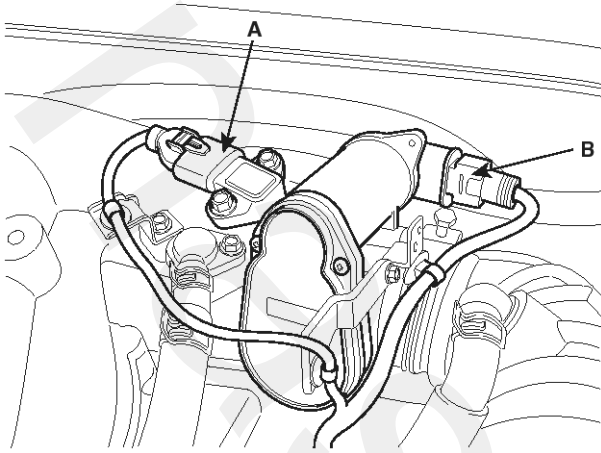

LDLG034A

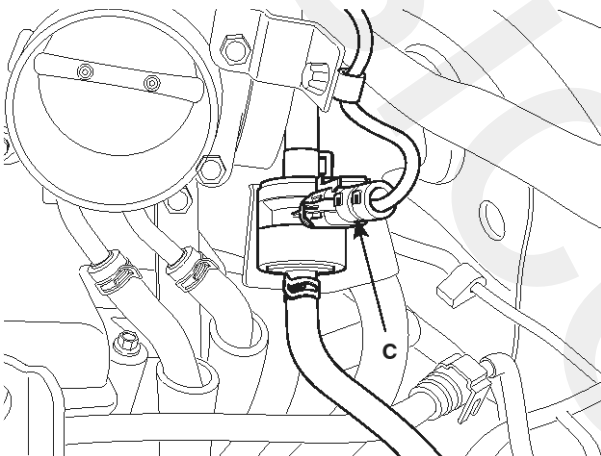

LDLG035A

- 6) Connect the injection harness connector(A), the No.2 VIS(Variable Induction System) connector(B), the No.1/No.2 OCV(Oil Control Valve) connectors(C,D) and the OTS(Oil Temperature Sensor) connector(E).

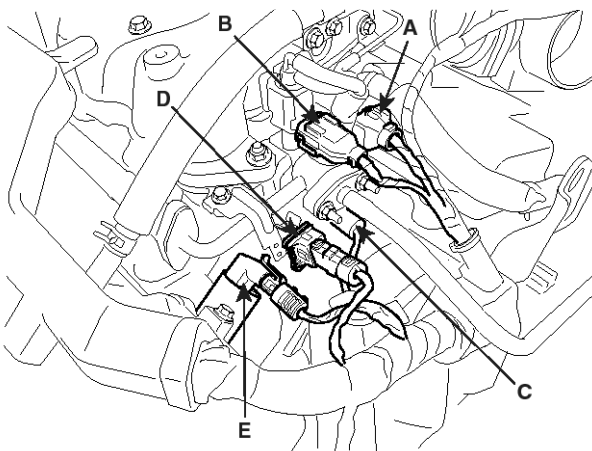

LDLG006A

- 7) Connect the injection connectors(A,B,C), the ground lines(D), the condenser connector(E) and the Ignition coil connectors(F).

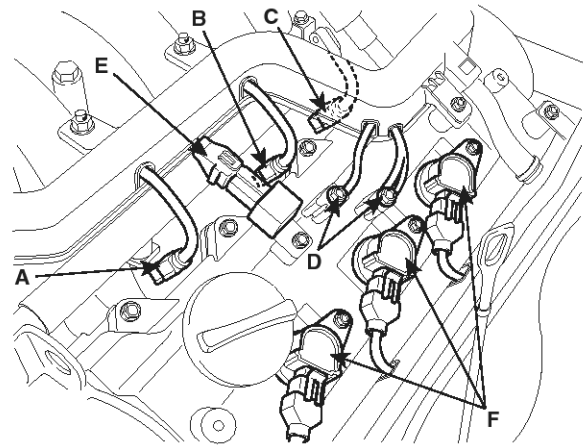

LDLG060A

- 8) Connect the bank 1 front/rear O2 sensor connectors(A).

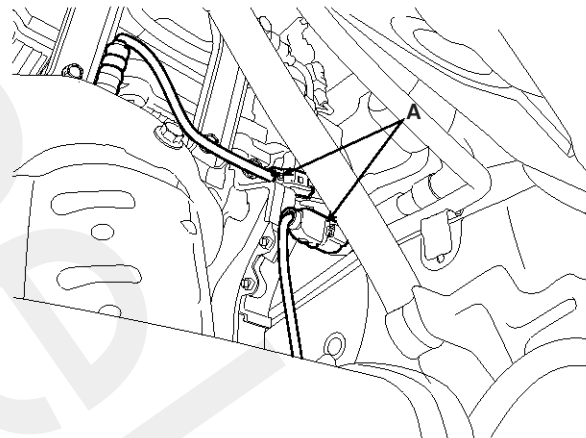

KCBF160A

- 9) Connect the No.1/No.2 knock sensor connectors(A,B), the oil pressure switch connector(C), the ignition coil harness(D) and the No.1 VIS(Variable Induction System) connector(E).



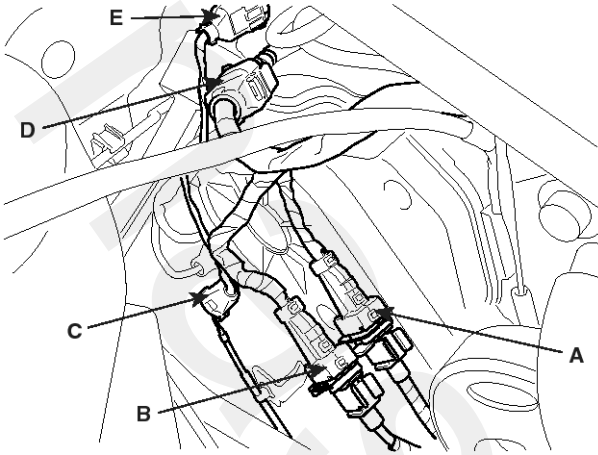

LDLG005A

23. Install the fuel inlet hose(A) from the delivery pipe.

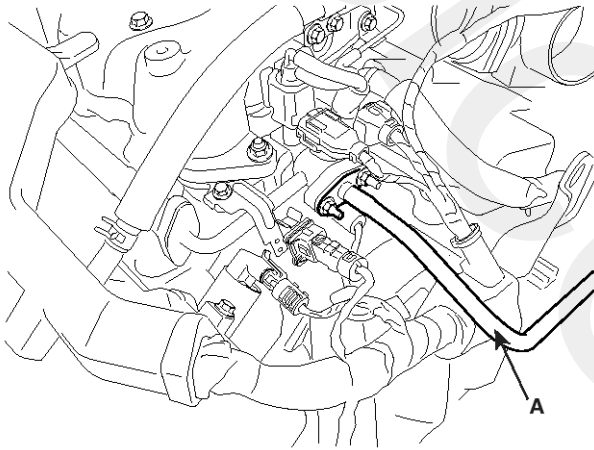

LDLG062A

24. Install the upper radiator hose(A) and lower radiator hose(B).

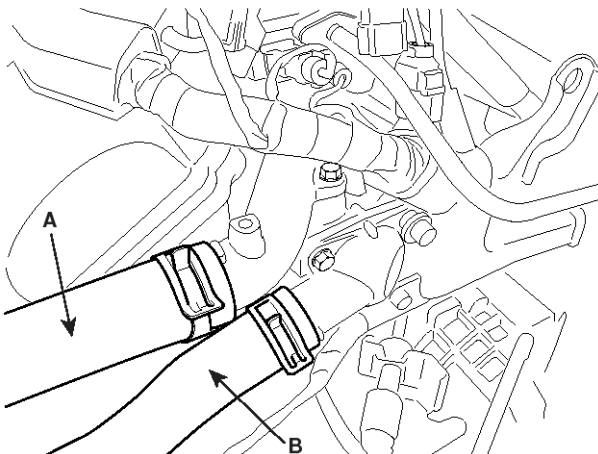

LDLG008A

25. Install the intake air hose and air cleaner assembly.

- 1) Install the intake air hose and air cleaner assembly(C).
- 2) Connect the breather hose(B) from air cleaner hose.
- 3) Connect the MAF connector(A).

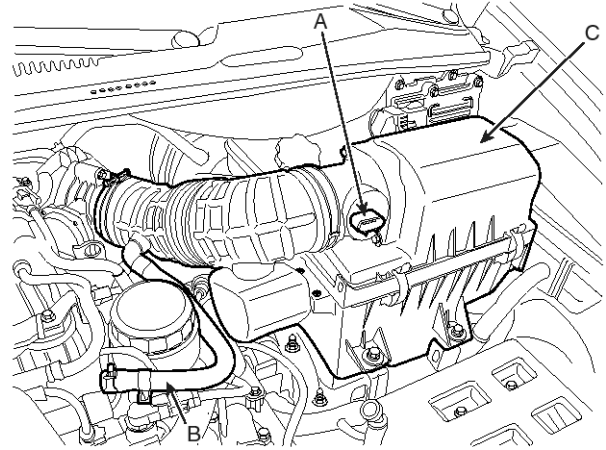

BCKG002A

26. Install the engine cover.

27. Refill engine coolant.

## Cylinder Block COMPONENTS

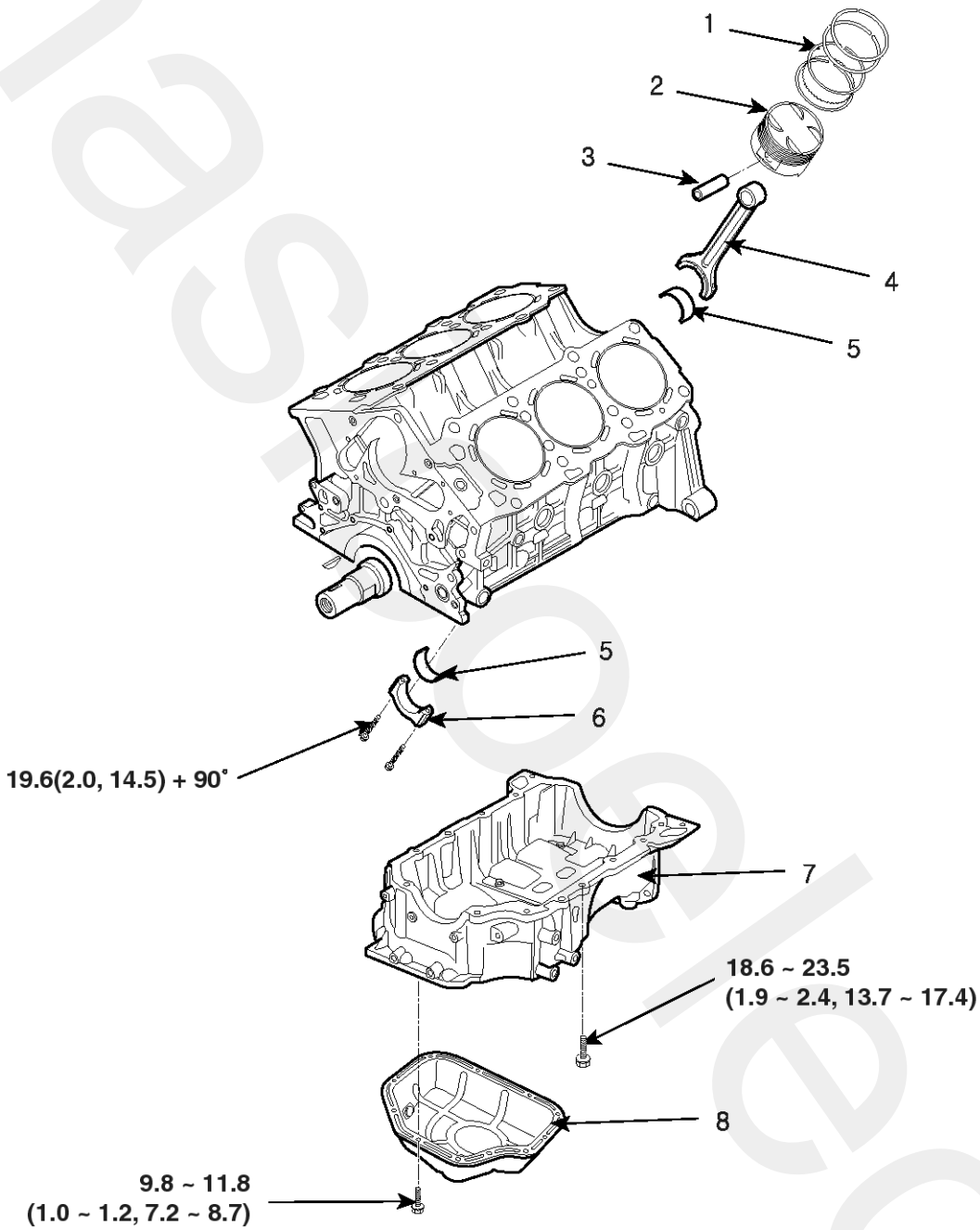

### TORQUE : N.m (kgf.m, lb-ft)

1. Piston ring
2. Piston
3. Piston pin
4. Connecting rod

5. Connecting rod bearing
6. Connecting rod cap
7. Upper oil pan
8. Lower oil pan

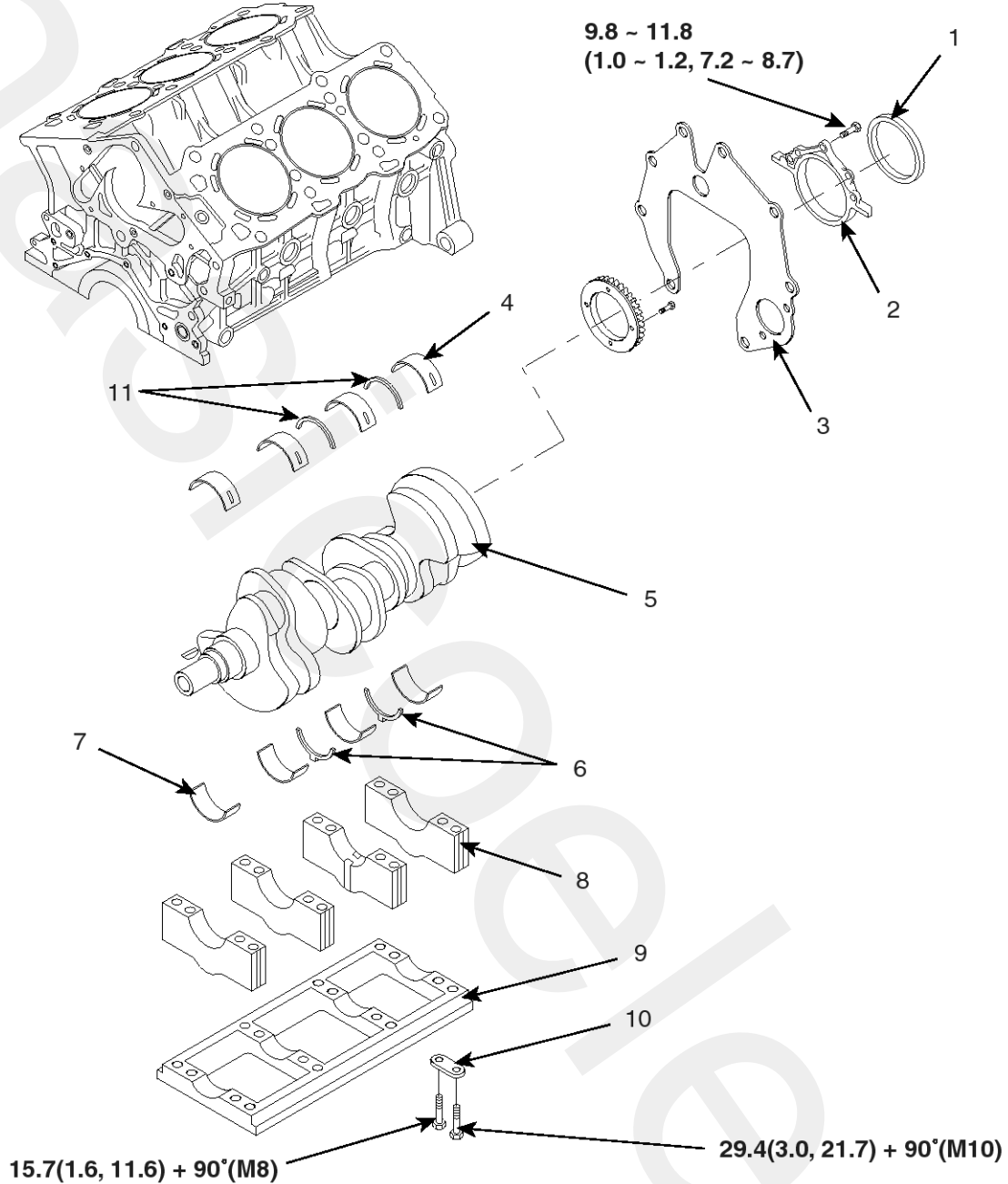

**TORQUE : N.m (kgf.m, lb-ft)**

- |                             |                             |
|-----------------------------|-----------------------------|
| 1. Rear oil seal            | 7. Crankshaft lower bearing |
| 2. Rear oil seal case       | 8. Main bearing cap         |
| 3. Rear plate               | 9. Bearing cap bridge       |
| 4. Crankshaft upper bearing | 10. Bearing cap bolt washer |
| 5. Crankshaft               | 11. Upper thrust bearing    |
| 6. Lower thrust bearing     |                             |

## REMOVAL

1. Remove the drive plate(A).

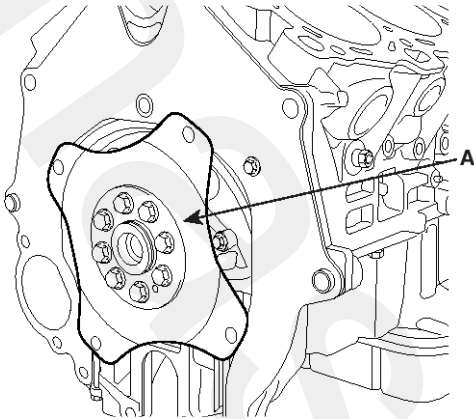

KCBF120A

2. Remove the rear plate(A).

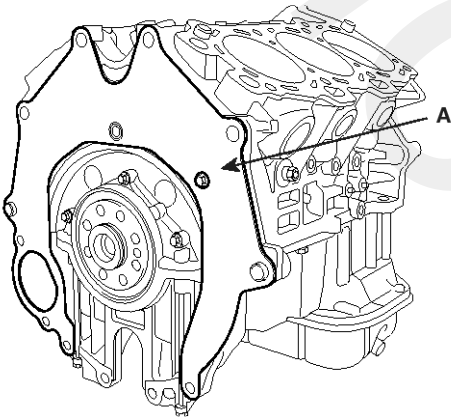

KCBF121A

3. Remove timing belt.
4. Remove intake manifold.
5. Remove exhaust manifold.
6. Remove generator from engine.(Refer to 'ST' group).
7. Remove power steering pump from engine.(Refer to 'HA' group).
8. Remove cylinder head.
9. Remove A/C compressor from engine.(Refer to 'EE' group).
- 10.Remove water pump assembly.

## DISASSEMBLY

1. Remove the power steering pump bracket(A) and the knock sensor(B).

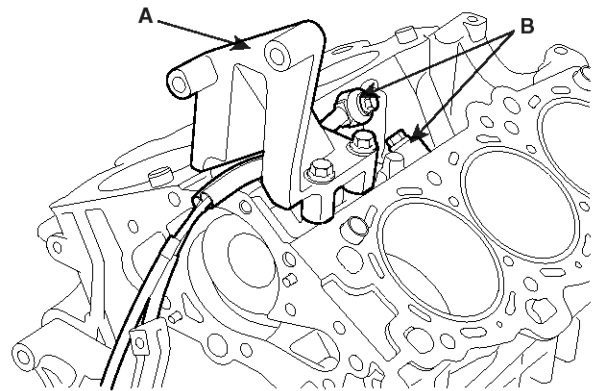

KCBF122A

2. Remove the air conditioning compressor bracket(A).

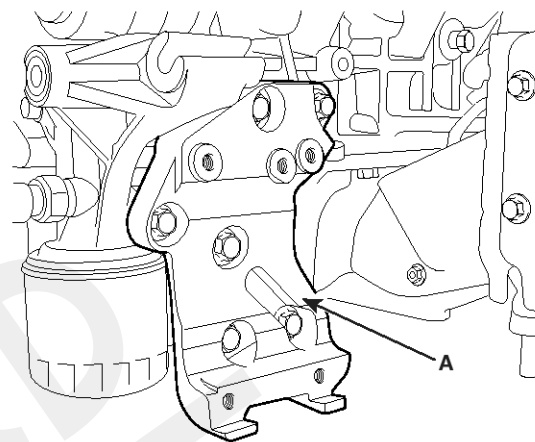

KCBF138A

3. Remove the lower oil pan(A).

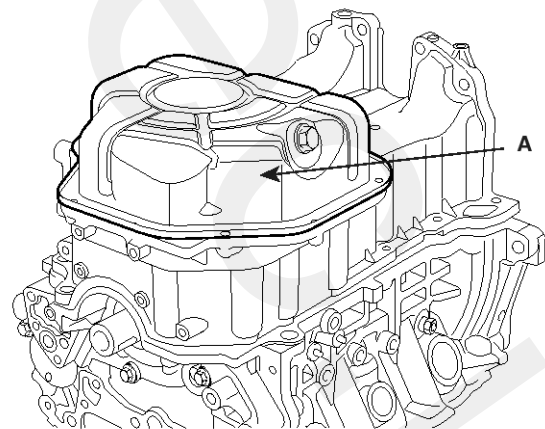

KCBF123A

4. Remove the oil screen(A).

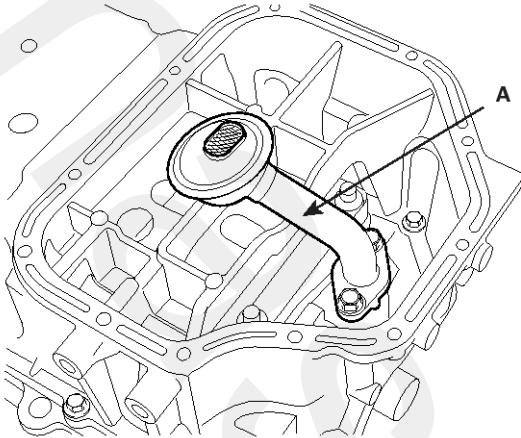

KCBF124A

5. Remove the upper oil pan(A).

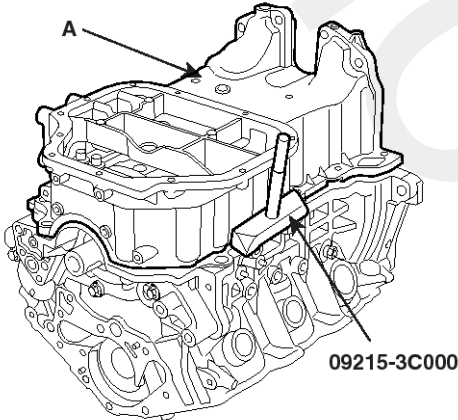

09215-3C000

KCBF125B

**CAUTION**

When removing the oil pan, use the SST(09215-3C000) not to damage the contacting surface of the oil pan.

6. Check the connecting rod side clearance.
7. Check the connecting rod bearing oil clearance.
8. Remove the piston and connecting rod assemblies.

**NOTICE**

- Keep the bearings the connecting rods and the caps together.
- Arrange the piston and connecting rod assemblies in the correct order.

9. Remove the oil pump case.
10. Remove the oil seal case(A).

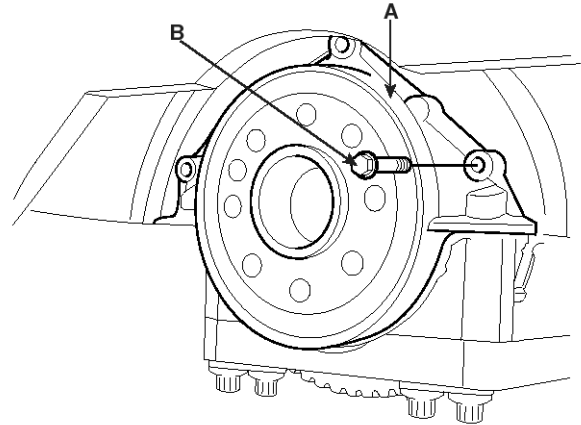

EDQF174B

11. Check the crankshaft end play.

12. Remove the crankshaft bearing cap and check oil clearance.

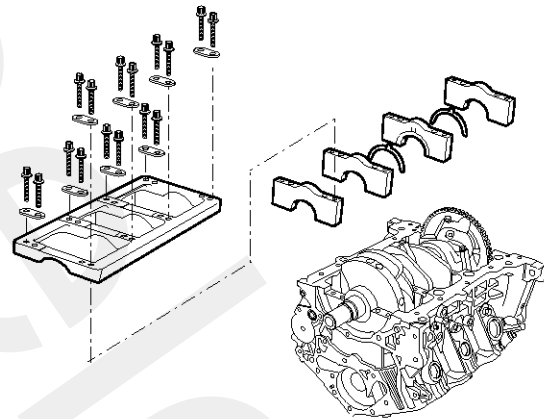

KCBF126A

**NOTICE**

Arrange the bearings and the bearing caps in order.

13. Lift the crankshaft(A) out of the block, being careful not to damage journals.

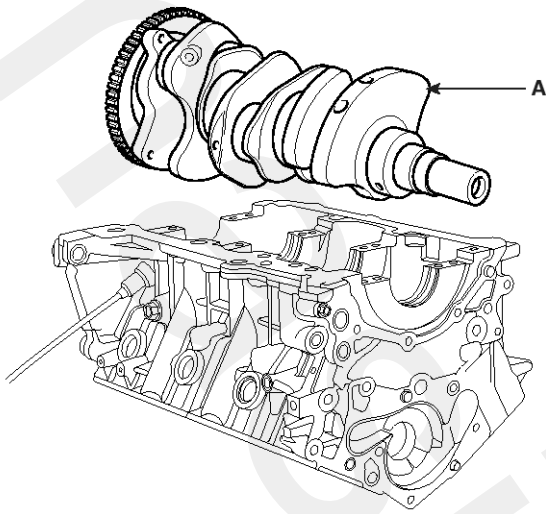

EDQF074A

14. Remove and arrange the main bearings and thrust bearings in the correct order.

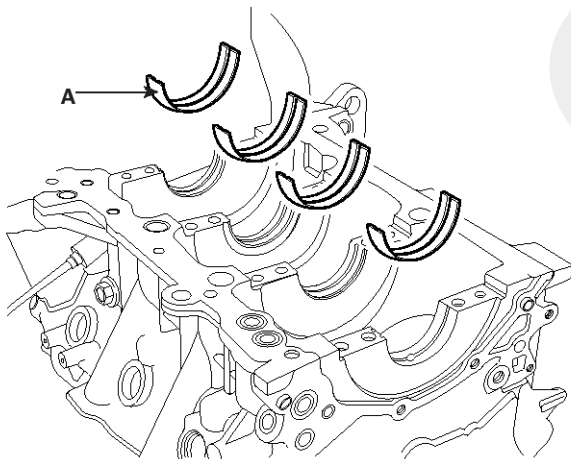

EDQF076A

15. Remove the CKP sensor(A).

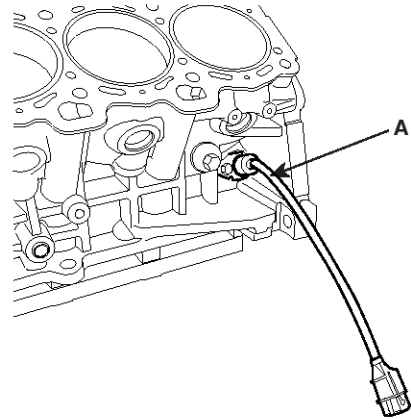

KCBF128A

16. Check the free play between a piston and a piston pin.

Try to move the piston back and forth on the piston pin. If any movement is felt, replace the piston and the piston pin as a set.

17. Remove the piston rings.

- 1) Using a piston ring expander, remove the 2 compression rings.
- 2) Remove the 2 side rails and the oil ring by hand.

**NOTICE**

*Arrange the piston rings in the correct order only.*

18. Disconnect the connecting rod from the piston.

Using a press, remove the piston pin from the piston.  
(Press-in load : 2451.7 ~ 12258.3N(250 ~ 1250kg, 551.2 ~ 2755.81lb)

## INSPECTION

## CONNECTING ROD AND CRANKSHAFT

1. Check the connecting rod side clearance.  
Using a feeler gauge, measure the side clearance while moving the connecting rod back and forth.

## Specification

Standard : 0.1~ 0.25mm(0.0039 ~ 0.0098in.)

Limit : 0.4mm(0.0157in.)

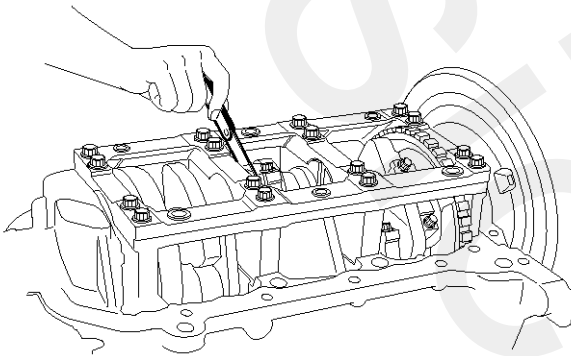

EDQF159A

- If out-of-tolerance, install a new connecting rod.
  - If still out-of-tolerance, replace the crankshaft.
2. Check the connecting rod bearing oil clearance.
    - 1) Check the matchmarks on the connecting rod and cap are aligned to ensure correct reassembly.
    - 2) Remove the 2 connecting rod cap bolts.
    - 3) Remove the connecting rod cap and the lower bearing.
    - 4) Clean the crankshaft pin journal and the bearing.
    - 5) Place a plastigage across the crankshaft pin.
    - 6) Reinstall the lower bearing and the connecting rod cap and torque the bolts.

## Tightening torque

17.7~21.6Nm (1.8~2.2kgf.m, 13.0~15.9lb-ft) + 90~94°

## NOTICE

Do not turn the crankshaft.

## CAUTION

Always use new connecting rod cap bolts.

- 7) Remove the connecting rod cap again.
- 8) Measure the plastigage at its widest point.

## Standard oil clearance

0.018 ~ 0.036mm(0.0007 ~ 0.0014in.)

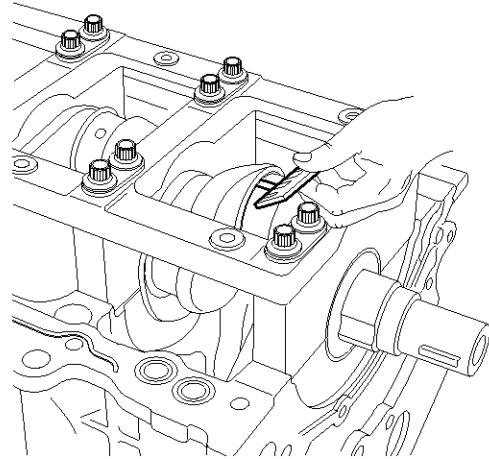

EDQF175A

- 9) If the plastigage measures too wide or too narrow, remove the upper half of the bearing, install a new, complete bearing with the same color mark (select the color as shown in the next column), and recheck the clearance.

## CAUTION

Do not file, shim, or scrape the bearings or the caps to adjust clearance.

- 10) If the plastigage shows the clearance is still incorrect, try the next larger or smaller bearing (the color listed above or below that one), and check clearance again.

## NOTICE

If the proper clearance cannot be obtained by using the appropriate larger or smaller bearings, replace the crankshaft and start over.

## CAUTION

If the marks are indecipherable because of an accumulation of dirt and dust, do not scrub them with a wire brush or scraper. Clean them only with solvent or detergent.

## CONNECTING ROD MARK LOCATION

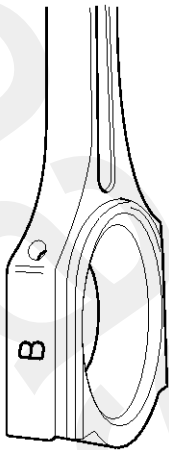

EDQF196A

## DISCRIMINATION OF CONNECTING ROD

CLASS	MARK	INSIDE DIAMETER
0	a	51.000 ~ 51.006mm (2.0079 ~ 2.0081in.)
1	b	51.006 ~ 51.012mm (2.0081 ~ 2.0083in.)
2	c	51.012 ~ 51.018mm (2.0083 ~ 2.0086in.)

## CRANKSHAFT PIN MARK LOCATION DISCRIMINATION OF CRANKSHAFT

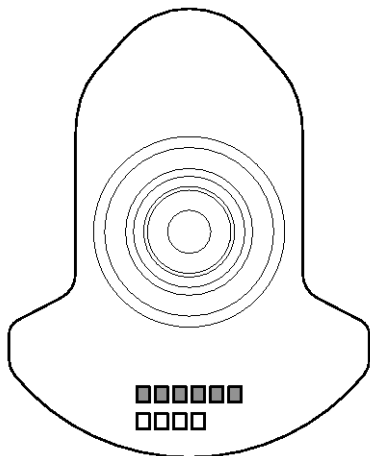

EDQF176B

## DISCRIMINATION OF CRANKSHAFT

CLASS	MARK	OUTSIDE DIAMETER OF PIN
I	1 or A	47.994 ~ 48.000mm (1.8895 ~ 1.8898in.)
II	2 or B	47.988 ~ 47.994mm (1.8893 ~ 1.8895in.)
III	3 or C	47.982 ~ 47.988mm (1.8891 ~ 1.8893in.)

## PLACE OF IDENTIFICATION MARK (CONNECTING ROD BEARING)

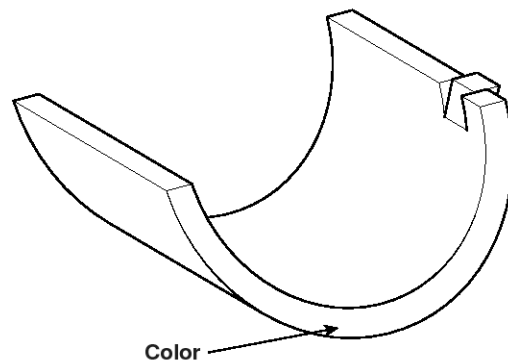

ECRF021A

## DISCRIMINATION OF CONNECTING ROD BEARING

CLASS	MARK	THICKNESS OF BEARING
A	BLUE	1.5000 ~ 1.503mm (0.0591 ~ 0.0592in.)
B	BLACK	1.497 ~ 1.500mm (0.0589 ~ 0.0591in.)
C	-	1.494 ~ 1.497mm (0.0588 ~ 0.0589in.)
D	GREEN	1.491 ~ 1.494mm (0.0587 ~ 0.0588in.)
E	YELLOW	1.488 ~ 1.491mm (0.0586 ~ 0.0587in.)



- 11) Select the proper connecting rod bearing from the table below.

		CONNECTING ROD IDENTIFICATION MARK		
		0(A)	1(B)	2(C)
CRANKSHAFT IDENTIFICATION MARK	I(A)	E (YELLOW)	D (GREEN)	C (-)
	II(B)	D (GREEN)	C (-)	B (BLACK)
	III(C)	C (-)	B (BLACK)	A (BLUE)

3. Check the connecting rod.

- 1) When reinstalling, check the cylinder numbers on the connecting rods and the caps. When installing a new connecting rod, the notches for bearing fixing on the connecting rods and caps should face the same direction.
- 2) If one or both edge of the connecting rod thrust surface is damaged, replace the rod. If the inner surface of the rod is damaged or rough, also replace it.
- 3) Using a connecting rod aligner, measure the bent or torsion of the rod. If the measurement is near the specification, adjust the rod with a press. If the rod is bent or twisted excessively, replace it.

Bending : 0.05mm/100mm(0.0020in./3.9370in.)

Torsion : 0.1mm/100mm(0.0039in./3.9370in.)

**NOTICE**

When assembling the rod without a bearing, there should be no difference.

4. Check the crankshaft bearing oil clearance.

- 1) To check main bearing-to-journal oil clearance, remove the main bearing caps and bearing halves.
- 2) Clean each main journal and bearing half with a clean shop towel.
- 3) Place one strip of plastigage across each main journal.
- 4) Reinstall the bearings and caps, then torque the bolts.

**Tightening torque**

M8 : 12.7~18.6Nm (1.3~1.9kgf.m, 9.4~13.7lb-ft) + 90~95°

M10 : 26.5~32.4Nm (2.7~3.3kgf.m, 19.5~23.9lb-ft) + 90~95°

**NOTICE**

Tighten the bolts in order.

**CAUTION**

Always use new main bearing cap bolts.

- 5) Remove the cap and bearing again, and measure the widest part of the plastigage.

Standard oil clearance

0.004~0.022mm (0.0002 ~ 0.0009in.)

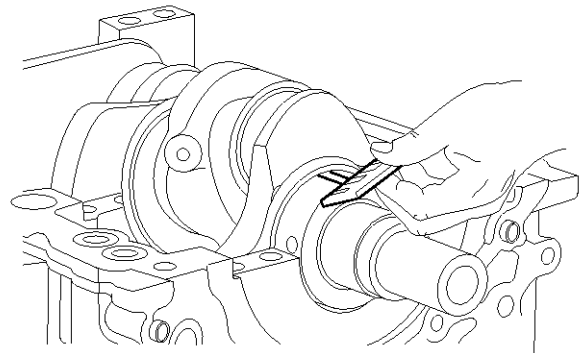

EDQF075A

- 6) If the plastigage measures too wide or too narrow, remove the upper half of the bearing, install a new, complete bearing with the same color mark (select the color as shown in the next column), and recheck the clearance.

**CAUTION**

Do not file, shim, or scrape the bearings or the caps to adjust clearance.

- 7) If the plastigage shows the clearance is still incorrect, try the next larger or smaller bearing (the color listed above or below that one), and check clearance again.

**NOTICE**

If the proper clearance cannot be obtained by using the appropriate larger or smaller bearings, replace the crankshaft and start over.

**CAUTION**

If the marks are indecipherable because of an accumulation of dirt and dust, do not scrub them with a wire brush or scraper. Clean them only with solvent or detergent.

Crankshaft bore mark location

Letters have been stamped on the block as a mark for the each size of the 4 main journal bores.

No.1 journal stamping mark starts from the front of the engine.

Use the size marks which are stamped on the block and the crankshaft for the journal bore inner diameter and the journal outer diameter to choose the correct bearings.

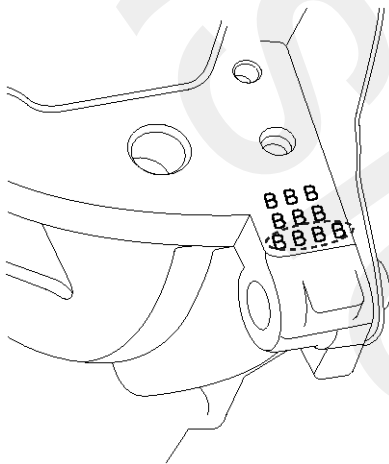

EDQF078A

### DISCRIMINATION OF CYLINDER BLOCK

CLASS	MARK	INSIDE DIAMETER
a	A	66.000 ~ 66.006mm (2.5984 ~ 2.5987in.)
b	B	66.006 ~ 66.012mm (2.5987 ~ 2.5989in.)
c	C	66.012 ~ 66.018mm (2.5989 ~ 2.5991in.)

**CRANKSHAFT JOURNAL MARK LOCATION**

### DISCRIMINATION OF CRANKSHAFT

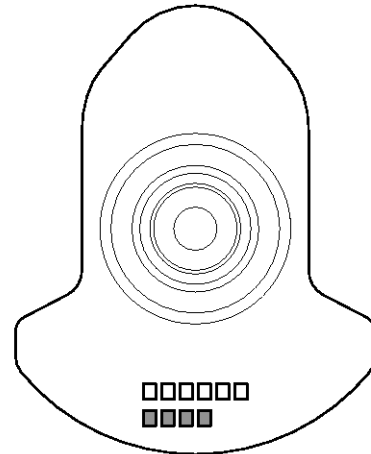

EDQF176A

### DISCRIMINATION OF CRANKSHAFT

CLASS	MARK	OUTSIDE DIAMETER OF JOURNAL
I	A	61.994 ~ 62.000mm (2.4407 ~ 2.4409in.)
II	B	61.988 ~ 61.994mm (2.4405 ~ 2.4407in.)
III	C	61.982 ~ 61.988mm (2.4402 ~ 2.4405in.)

### PLACE OF IDENTIFICATION MARK (CRANKSHAFT BEARING)

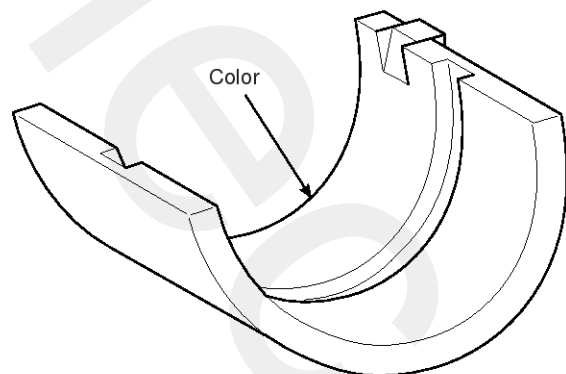

ECRF022A

## DISCRIMINATION OF CRANKSHAFT BEARING

CLASS	MARK	THICKNESS OF BEARING
A	BLUE	2.007 ~ 2.010mm (0.0790 ~ 0.0791in.)
B	BLACK	2.004 ~ 2.007mm (0.0789 ~ 0.0790in.)
C	-	2.001 ~ 2.004mm (0.0788 ~ 0.0789in.)
D	GREEN	1.998 ~ 2.001mm (0.0787 ~ 0.0788in.)
E	YELLOW	1.995 ~ 1.998mm (0.0785 ~ 0.0787in.)

## SELECTION TABLE

		CRANKSHAFT BORE IDENTIFICATION MARK		
		a(A)	b(B)	c(C)
CRANKSHAFT IDENTIFICATION MARK	I(A)	E (YELLOW)	D (GREEN)	C (-)
	II(B)	D (GREEN)	C (-)	B (BLACK)
	III(C)	C (-)	B (BLACK)	A (BLUE)

### 5. Check crankshaft end play.

Using a dial indicator, measure the thrust clearance while prying the crankshaft back and forth with a screwdriver.

Standard end play

0.07 ~ 0.25mm (0.0028 ~ 0.0098in.)

[Limit]

0.3mm(0.0118in.)

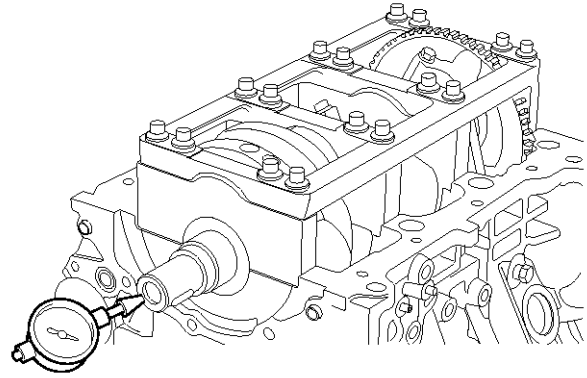

KCBF127A

If the end play is greater than the maximum, replace the center bearing.

Thrust bearing thickness

1.925 ~ 1.965mm(0.0758 ~ 0.0774in.)

6. Inspect the main journals and the pin journals of the crankshaft.

7. Using a micrometer, measure the outer diameter of each main journal and pin journal.

Main journal diameter : 61.982~ 62.000mm (2.4402 ~ 2.4409in.)

Crank pin diameter : 47.982 ~ 48.000mm (1.8891 ~ 1.8898in.)

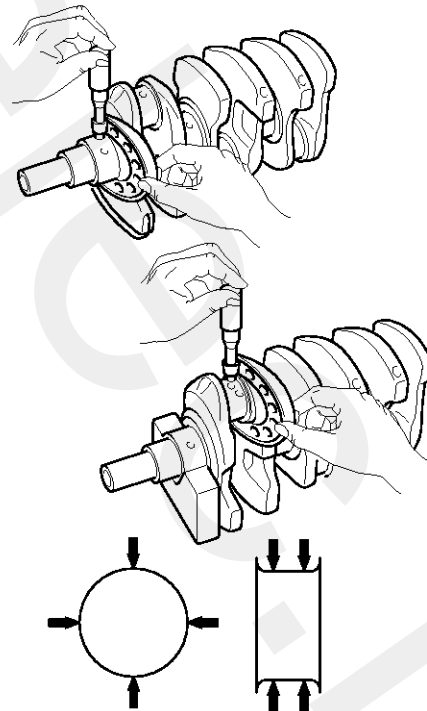

KCRF212A

## CYLINDER BLOCK

### 1. Remove gasket materials.

Using a gasket scraper, remove all the gasket material from the top surface of the cylinder block.

### 2. Clean cylinder block

Using a soft brush and solvent, thoroughly clean the cylinder block.

### 3. Inspect the top surface of cylinder block for flatness.

Using a precision straight edge and feeler gauge, measure the surface contacting the cylinder head gasket for warpage.

Flatness of cylinder block gasket surface  
Standard : 0.03mm(0.0012in.) or less

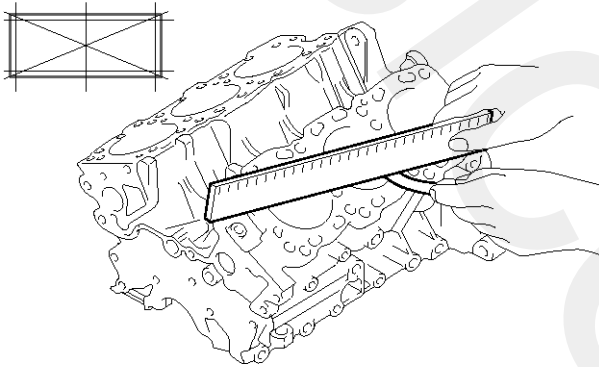

LDLG044A

### 4. Inspect cylinder bore diameter

Visually check the cylinder for vertical scratches.

If deep scratches are present, replace the cylinder block or process the piston to be oversized.

### 5. Inspect the cylinder bore diameter

Using a cylinder bore gauge, measure the cylinder bore diameter at position in the thrust and axial directions.

Standard diameter

86.70 ~ 86.73mm (3.4134 ~ 3.4146in.)

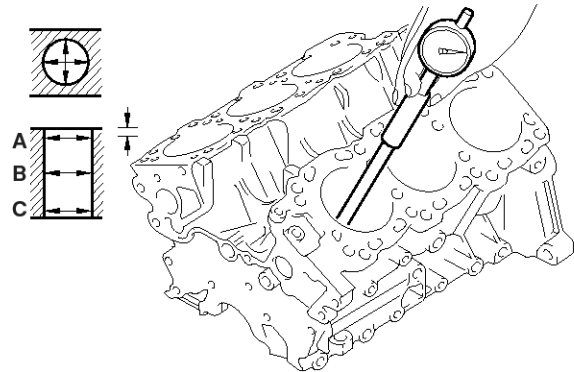

EDQF153A

### 6. Check the cylinder bore size code(A) on the cylinder block.

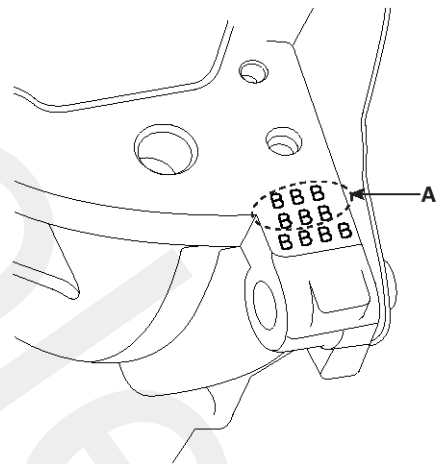

EDQF078B

Class	Size code	Cylinder bore inner diameter
A	A	86.70 ~ 86.71mm (3.4134 ~ 3.4138in.)
B	B	86.71 ~ 86.72mm (3.4138 ~ 3.4142in.)
C	C	86.72 ~ 86.73mm (3.4142 ~ 3.4146in.)

### 7. Check the piston size code(A) on the piston top face.

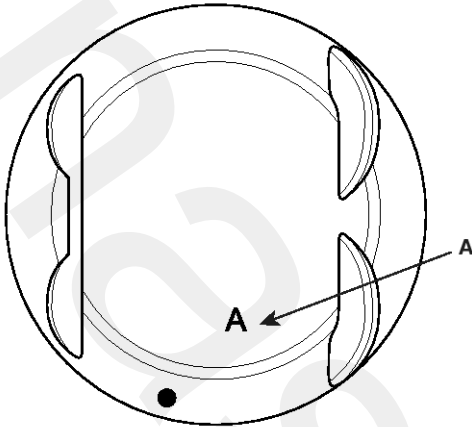

KCBF176D

Class	Size code	Piston outer diameter
A	A	86.67 ~ 86.68mm (3.4122 ~ 3.4126in.)
B	-	86.68 ~ 86.69mm (3.4126 ~ 3.4130in.)
C	C	86.69 ~ 86.70mm (3.4130 ~ 3.4134in.)

8. Select the proper piston related to the cylinder bore class.

Clearance : 0.02 ~ 0.04mm(0.0008 ~ 0.0016in.)

### CYLINDER BORING

1. The over size piston is chosen on the maximum inner diameter of the cylinder.

#### NOTICE

The piston size mark is on the top surface of the piston.

2. Measure the outer diameter of the piston which is installed before.  
3. Calculate the new bore size with the measurement in the step 2.

New bore size = measured outer diameter of piston + 0.02 ~ 0.04mm(0.0008~0.0016in.)[clearance] - 0.01mm(0.0004in.)[for honing]

4. Bore the cylinder to the calculated size.

#### CAUTION

Bore the cylinders in firing order to prevent the cylinders from be twisted by high temperature.

5. Stop boring and start honing for the proper clearance.  
6. Measure the clearance between a piston and a cylinder.

#### Specification

0.02 ~ 0.04mm(0.0008 ~ 0.0016in.)

#### NOTICE

Bore all the cylinders with the same over size.

### PISTON AND RINGS

1. Clean pistons.  
1) Using a gasket scraper, remove the carbon from the piston top.  
2) Using a groove cleaning tool or a broken ring, clean the piston ring grooves.  
3) Using solvent and a brush, thoroughly clean the piston.

#### NOTICE

Do not use a wire brush.

2. The standard measurement of the piston outside diameter is taken 14 mm (0.5512 in.) from the bottom of the piston.

#### Standard diameter

86.67 ~ 87.00(3.4122 ~ 3.4252in.)

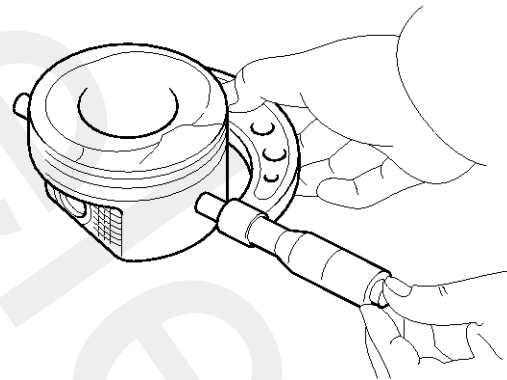

ECKD001D

3. Calculate the difference between the cylinder bore inner diameter and the piston outer diameter.

#### Piston-to-cylinder clearance

0.02 ~ 0.04mm(0.0008 ~ 0.0016in.)

## 4. Inspect the piston ring side clearance.

Using a feeler gauge, measure the clearance between a new piston ring and the ring groove.

### Piston ring side clearance

#### Standard

No.1 : 0.04 ~ 0.08mm (0.0016 ~ 0.0031in.)

No.2 : 0.03 ~ 0.07mm (0.0012 ~ 0.0027in.)

Oil ring : 0.06 ~ 0.15mm (0.0024 ~ 0.0059in.)

#### Limit

No.1 : 0.1mm (0.004in.)

No.2 : 0.1mm (0.004in.)

Oil ring : 0.2mm (0.008in.)

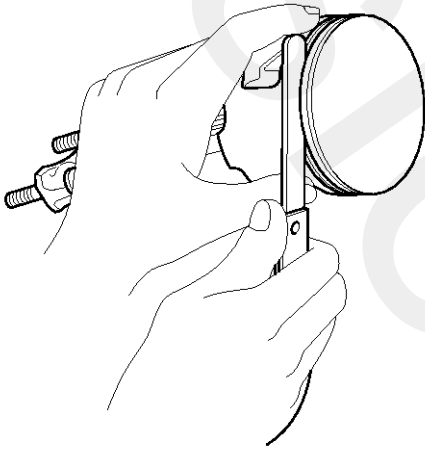

LDLG045A

If the clearance is greater than the maximum, replace the piston.

## 5. Inspect piston ring end gap.

To measure the piston ring end gap, insert a piston ring into the cylinder bore. Position the ring at right angles to the cylinder wall by gently pressing it down with a piston. Measure the gap with a feeler gauge. If the gap exceeds the service limit, replace the piston ring. If the gap is too large, recheck the cylinder bore diameter. If the bore is over the service limit, the cylinder block must be replaced or bored

### Piston ring end gap

#### Standard

No.1 : 0.15 ~ 0.30mm (0.0059 ~ 0.0118in.)

No.2 : 0.30 ~ 0.45m (0.0118 ~ 0.0177in.)

Oil ring : 0.20 ~ 0.70mm (0.0079 ~ 0.0275in.)

#### Limit

No.1 : 0.6mm (0.0236in.)

No.2 : 0.7mm (0.0275in.)

Oil ring : 0.8mm (0.0315in.)

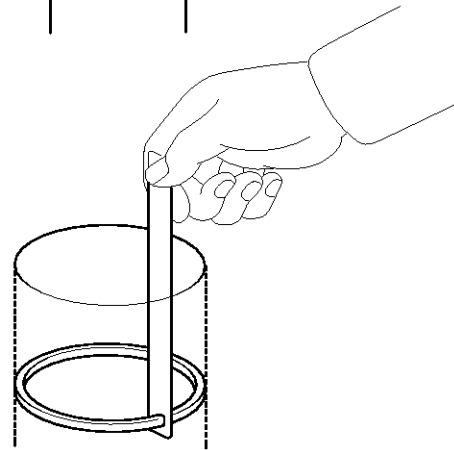
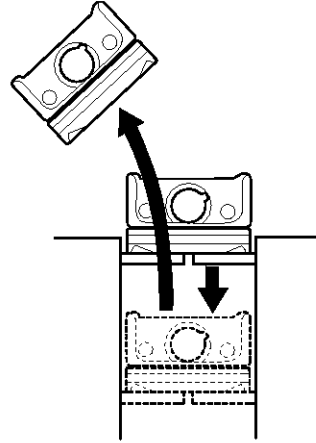

ECKD001K

## PISTON PINS

1. Measure the outer diameter of the piston pin.

### Piston pin outerdiameter

21.001 ~ 21.007mm (0.8268 ~ 0.8270in.)

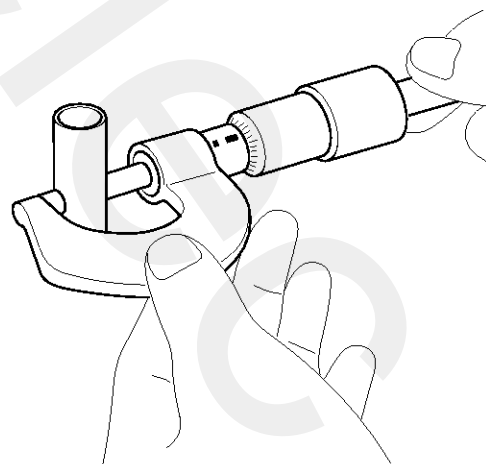

ECKD001Z

2. Measure the piston pin-to-piston clearance.

#### Piston pin-to-piston clearance

0.007 ~ 0.022mm (0.0003 ~ 0.0009in.)

3. Check the difference between the piston pin outer diameter and the connecting rod small end inner diameter.

#### Piston pin-to-connecting rod interference

-0.033 ~ -0.016mm (-0.0013 ~ -0.0006in.)

### REASSEMBLY

#### NOTICE

- Thoroughly clean all parts before reassembling.
- Before installing the parts, apply fresh engine oil to all sliding and rotating surfaces.
- Replace all gaskets, O-rings and oil seals with new parts.

1. Assemble the piston and the connecting rod.
  - 1) Use a hydraulic press for installation.
  - 2) The piston front mark(A) and the connecting rod front mark must face the timing belt side of the engine.

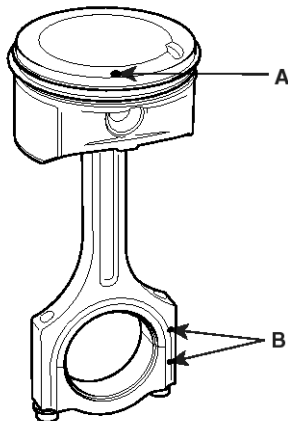

KCBF176E

2. Install piston rings.
  - 1) Install the oil ring spacer and 2 side rails by hand.
  - 2) Using a piston ring expander, install the 2 compression rings with the code mark facing upward.
  - 3) Position the piston rings so that the ring ends are as shown.

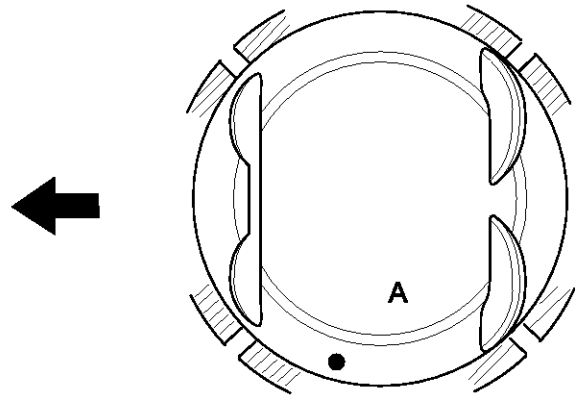

KCBF176F

3. Install the connecting rod bearings.
  - 1) Align the bearing(A) claw with the groove of the connecting rod or connecting rod cap(B).
  - 2) Install the bearings(A) in the connecting rod and connecting rod cap(B).

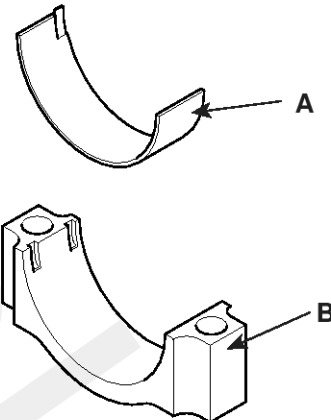

KCRF118B

#### CAUTION

When reassembling the connecting rods and the caps, ensure the front marks on them.

4. Install the CKP sensor(A).

Tightening torque

6.9 ~ 9.8Nm(0.7 ~ 1.0kgf.m, 5.1 ~ 7.2lb-ft)

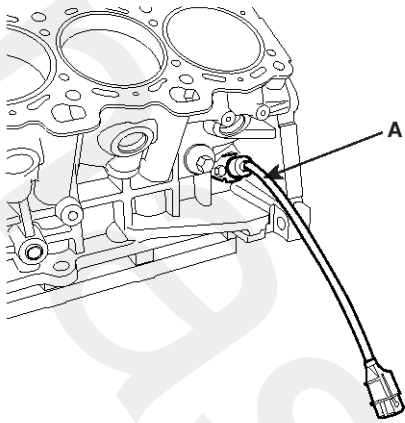

KCBF128A

5. Install main bearings.

### NOTICE

Upper bearings have the oil grooves of the oil holes; Lower bearings do not.

- 1) Aligning the bearing claw with the claw groove of the cylinder block, push in the 4 upper bearings(A).

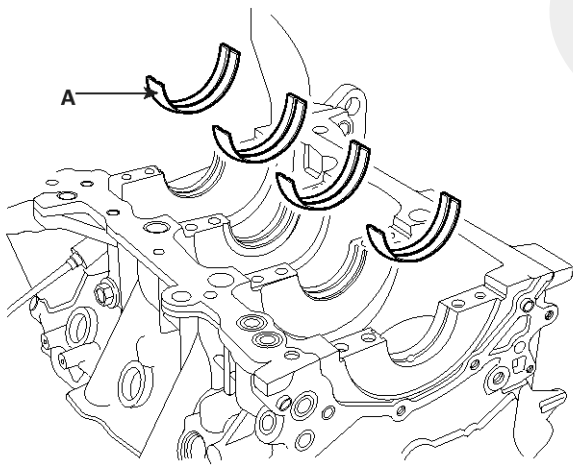

EDQF076A

- 2) Aligning the bearing claw with the claw groove of the main bearing cap, push in the 4 lower bearings(B) on the bearing caps(A).

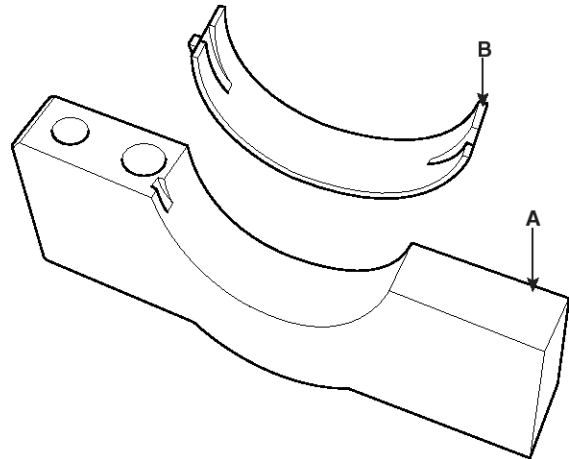

EDQF079A

6. Install thrust bearings.

Install the 2 thrust bearings(A) under the No.3 journal position of the cylinder block with the oil grooves facing outward.

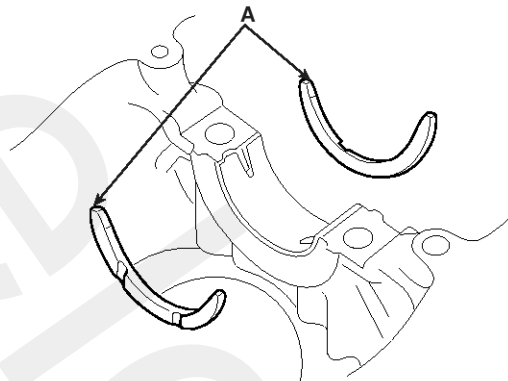

ECKD324A

7. Place crankshaft(A) on the cylinder block.



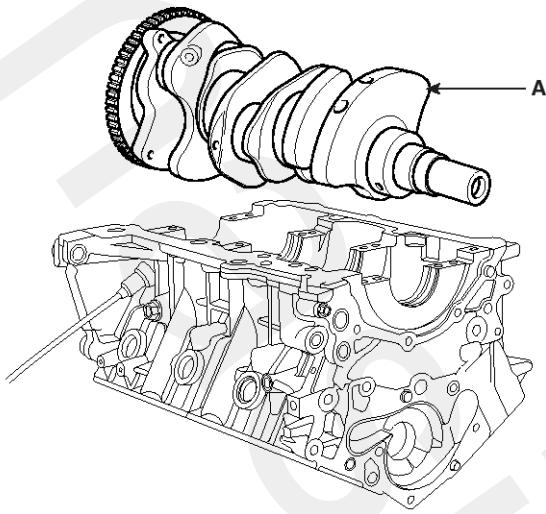

EDQF074A

8. Place main bearing caps on cylinder block.
9. Install main bearing cap bolts.
  - 1) Install and uniformly tighten the bearing cap bolts, in two steps, in the sequence shown.

**Tightening torque**

M8 : 12.7~18.6Nm (1.3~1.9kgf.m, 9.4~13.7lb-ft) + 90~95°

M10 : 26.5~32.4Nm (2.7~3.3kgf.m, 19.5~23.9lb-ft) + 90~95°

**NOTICE**

- Use new main bearing cap bolt with engine oil applied.
- If any of the bearing cap bolts are broken or deformed, replace it.
- Washers have their direction(Up/Down)
- Assemble the bearing cap bridge on which its arrow mark faces the engine front.
- Before tightening, make the bearing caps be seated on the block firmly.

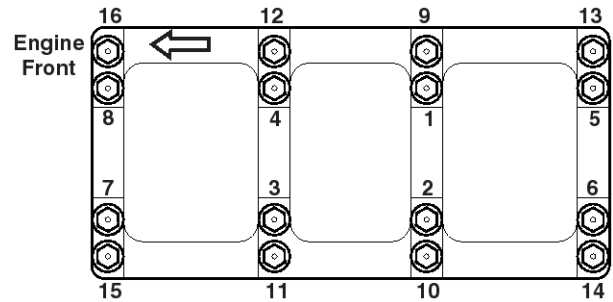

LDLG046A

**NOTICE**

Use SST( 09221-4A000 ), install main bearing cap bolts.

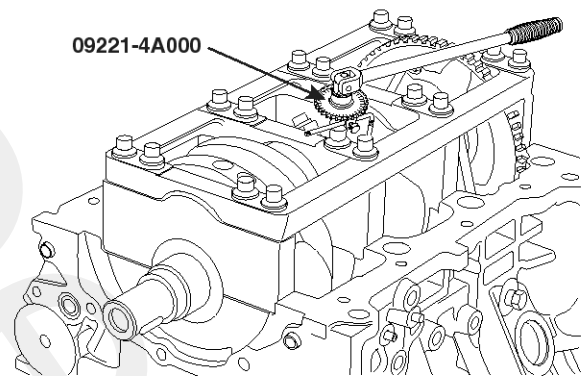

KCBF127B

- 2) Check that the crankshaft turns smoothly.
10. Check crankshaft end play.
  11. Install the piston and connecting rod assemblies.

**NOTICE**

- Before installing the pistons, apply a coat of engine oil to the ring grooves and cylinder bores.
- When installing the piston, ensure that the coat on the cylinder wall is not damaged or scratched.

- 1) Install the ring compressor, check that the bearing is securely in place, then position the piston in the cylinder, and tap it in using the wooden handle of a hammer.
- 2) Stop inserting the piston when the ring inserted in the cylinder and check the alignment of the journal and the connecting rod.
- 3) Apply engine oil to the bolt threads. Install the rod

caps with bearings, and torque the bolts.

## Tightening torque

17.7~21.6Nm (1.8~2.2kgf.m, 13.0~15.9lb-ft) + 90~94°

### NOTICE

- Always use new connecting rod bolts.
- Maintain downward force on the ring compressor to prevent the rings from expanding before entering the cylinder bore.

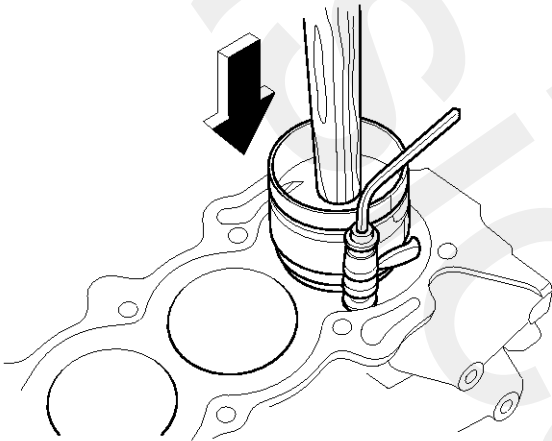

ECKD001F

- Use SST(09221-4A000), install connecting rod bearing cap bolts.

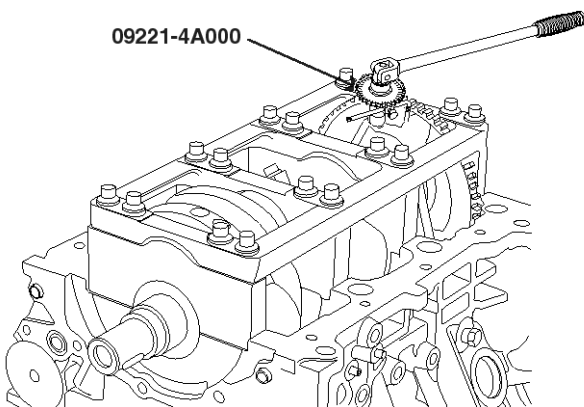

KCBF127C

12. Install the rear oil seal case.

## Tightening torque

9.80 ~ 11.76Nm (1.0 ~ 1.2kgf.m, 7.23 ~ 8.67lb-ft)

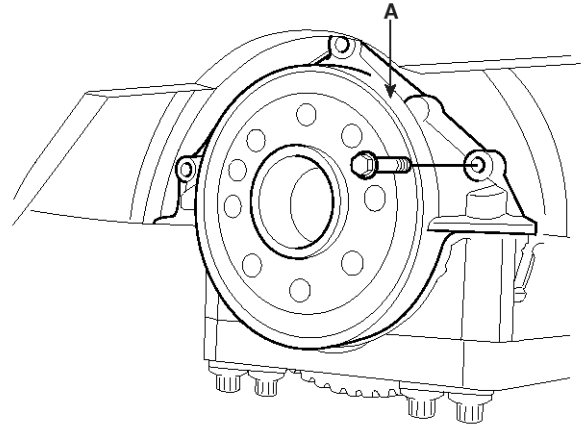

EDQF174A

- 1) Make clean the sealing face before assembling two parts.

### NOTICE

- Remove harmful foreign materials on the sealing face before applying sealant
- Apply sealant to the inner threads of the bolt holes.

- 2) Assembling rear oil seal case, the liquid sealant TB1217H should be applied to the rear oil seal case.

The part must be assembled within 5 minutes after sealant was applied.

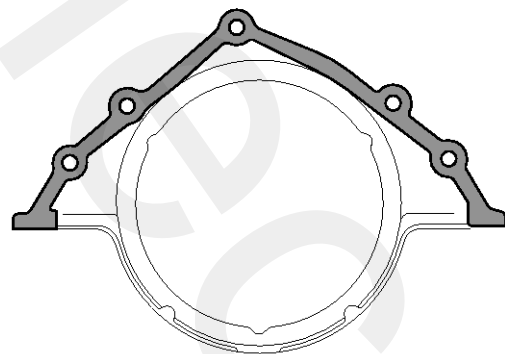

KCBF129A

13. Using SST(09231-33000), install rear oil seal after applying engine oil on the rip of the oil seal.

14. Install the oil pump case.

15. Install upper oil pan.

- 1) Using a gasket scraper, remove all the old packing material from the gasket surfaces.
- 2) Before assembling the oil pan, the liquid sealant TB1217H should be applied on upper oil pan.  
The part must be assembled within 5 minutes after the sealant was applied.

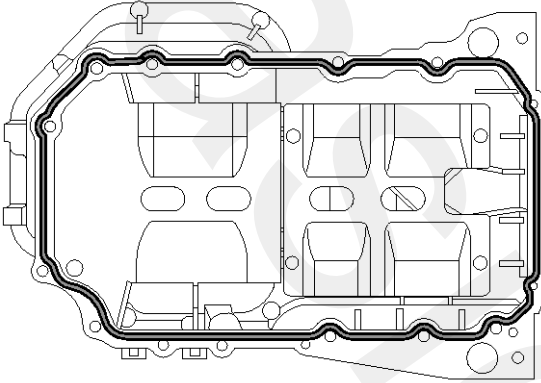

KCBF130A

**NOTICE**

- Clean the sealing face before assembling two parts.
- Remove harmful foreign materials on the sealing face before applying sealant.
- When applying sealant gasket, sealant must not protrude into the inside of oil pan.
- To prevent leakage of oil, apply sealant gasket to the inner threads of the bolt holes.

- 3) Install upper oil pan.  
Uniformly tighten the bolts in several passes.

**Tightening torque**

Bolts 1~15 : 18.6 ~ 23.5Nm(1.9 ~ 2.4kgf.m, 13.7 ~ 17.4lb-ft)

Bolts 16,17 : 4.9 ~ 6.9Nm(0.5 ~ 0.7kgf.m, 3.6 ~ 5.1lb-ft)

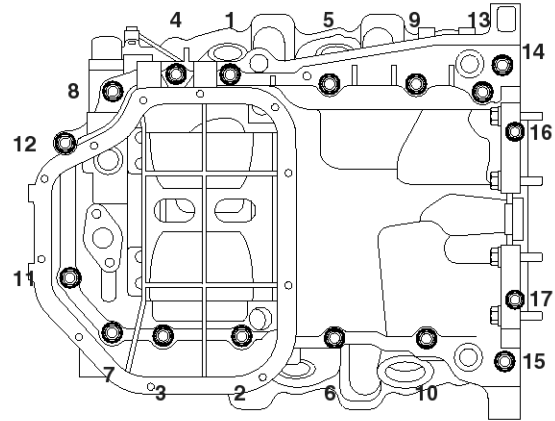

KCBF131A

16. Install the oil screen(A).

**Tightening torque**

14.7 ~ 21.6Nm (1.5 ~ 2.2kgf.m, 10.8 ~ 15.9lb-ft)

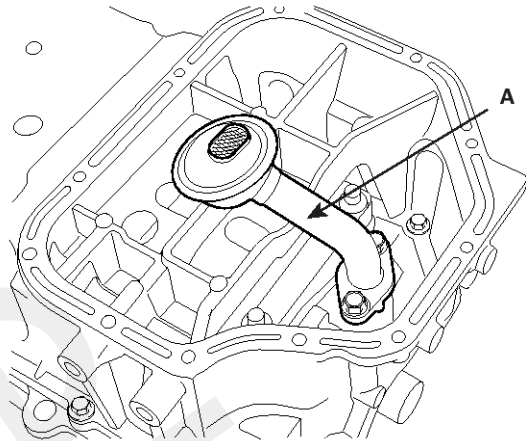

KCBF124A

17. Install the lower oil pan.

- 1) Using a gasket scraper, remove all the old packing material from the gasket surfaces.
- 2) Before assembling the oil pan, the liquid sealant TB1217H should be applied on lower oil pan.  
The part must be assembled within 5 minutes after the sealant was applied.

**NOTICE**

- Clean the sealing face before assembling two parts.
- Remove harmful foreign materials on the sealing face before applying sealant.
- When applying sealant gasket, sealant must not protrude into the inside of oil pan.
- To prevent leakage of oil, apply sealant gasket to the inner threads of the bolt holes.

3) Install lower oil pan.

Uniformly tighten the bolts in several passes.

### Tightening torque

9.8 ~ 11.8Nm (1.0 ~ 1.2kgf.m, 7.2 ~ 8.7lb-ft)

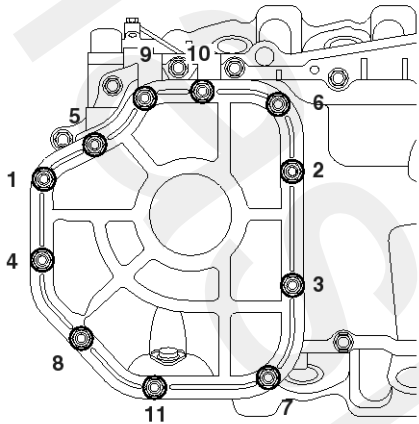

KCBF133A

18. Install the air conditioning compressor bracket(A).  
(Refer to 'HA' group)

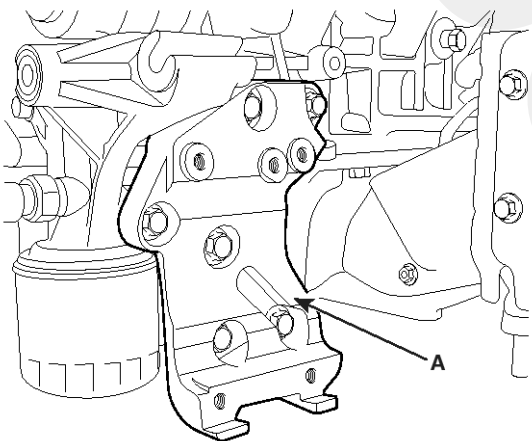

KCBF138A

19. Install the power steering pump bracket(A) and the knock sensor(B).

### Tightening torque

18.6 ~ 23.5Nm (1.9 ~ 2.4kgf.m, 13.7 ~ 17.4lb-ft)

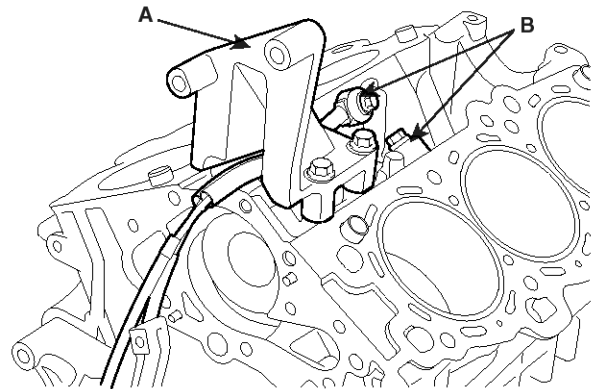

KCBF122A

### CAUTION

- On Bank 1, the black knock sensor connector should be installed and on Bank 2, the gray one should.

### INSTALLATION

1. Install the water pump.
2. Install the air conditioning compressor.(Refer to 'HA' group).
3. Install the cylinder head.
4. Install the power steering pump.(Refer to 'ST' group).
5. Install the generator.
6. Install the intake manifold.
7. Install the exhaust manifold.
8. Install the timing belt.
9. Install the rear plate(A).

### Tightening torque

9.8 ~ 11.8Nm(1.0 ~ 1.2kgf.m, 7.2 ~ 8.7lb-ft)

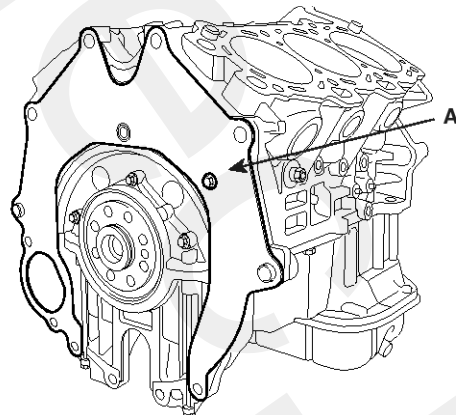

KCBF121A

10. Install the drive plate(A).

---

**Tightening torque**

71.6 ~ 75.5Nm(7.3 ~ 7.7kgf.m, 52.8 ~ 55.7lb-ft)

---

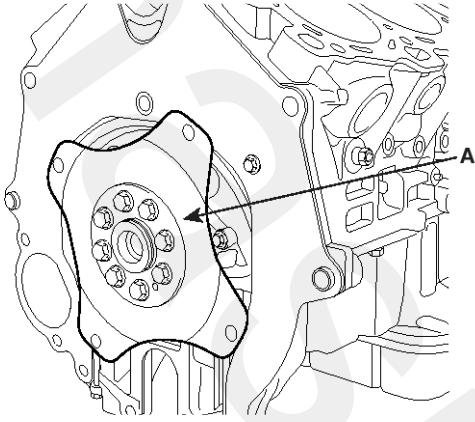

KCBF120A

## Cooling System COMPONENTS

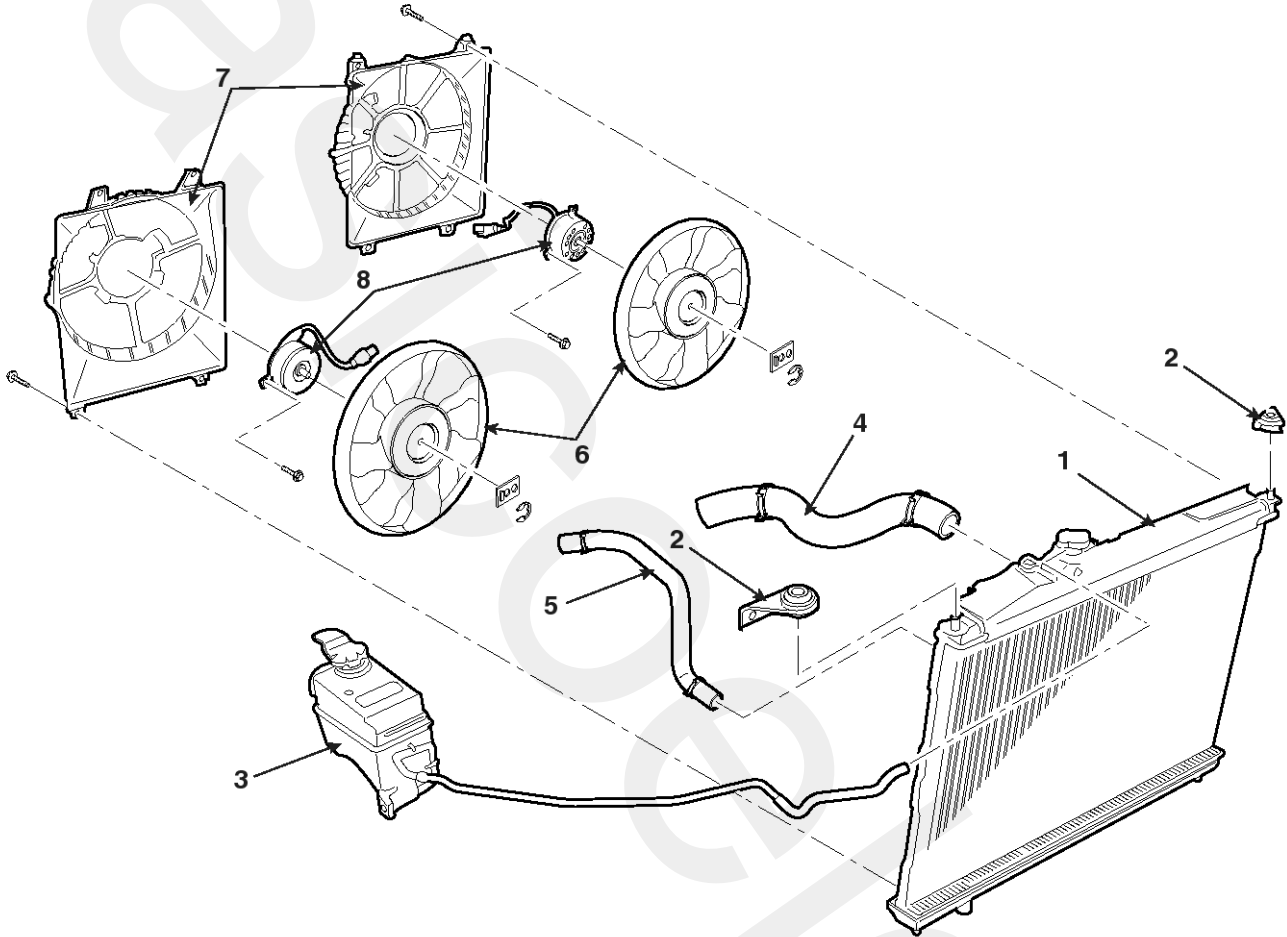

1. Radiator
2. Radiator bracket
3. Coolant reservoir tank
4. Radiator upper hose

5. Radiator lower hose
6. Radiator fan
7. Shroud
8. Motor assembly

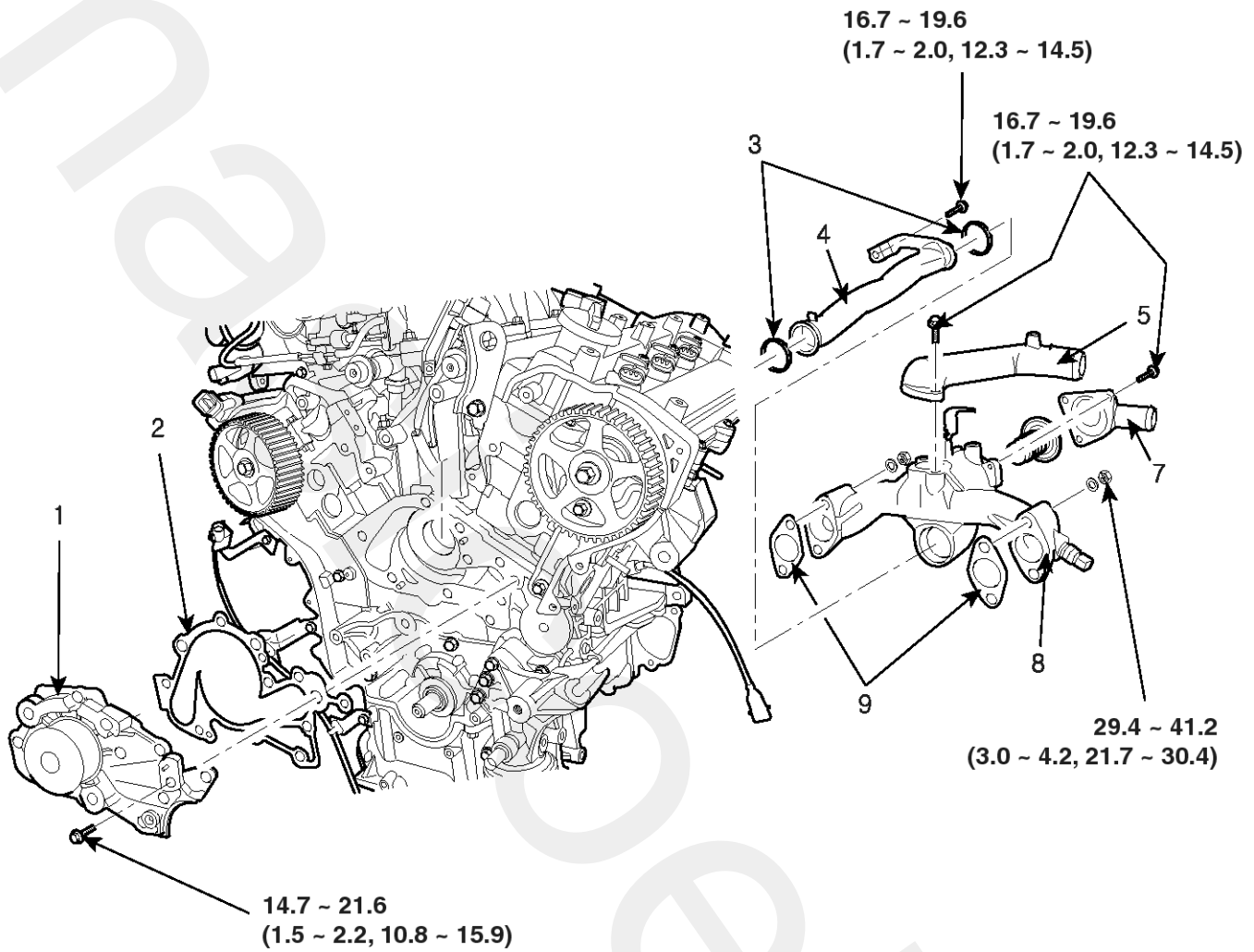

**TORQUE : N.m (kgf.m, lb-ft)**

- |                         |  |
|-------------------------|--|
| 1. Water pump           | 6. Thermostat                          |
| 2. Water pump gasket    | 7. Water inlet pitting                 |
| 3. Water pipe O-ring    | 8. Water temp. control assembly        |
| 4. Water inlet pipe     | 9. Water temp. control assembly gasket |
| 5. Water outlet pitting |  |

## ENGINE COOLANT REFILLING AND BLEEDING

### ⚠WARNING

Never remove the radiator cap when the engine is hot. Serious scalding could be caused by hot fluid under high pressure escaping from the radiator.

### ⚠CAUTION

When pouring engine coolant, be sure to shut the relay box lid and not to let coolant spill on the electrical parts or the paint. If any coolant spills, rinse it off immediately.

1. Make sure the engine and radiator are cool to the touch.
2. Open the radiator cap.
3. Loosen the drain plug, and drain the coolant.
4. Tighten the radiator drain plug securely.
5. Remove, drain and clean the reservoir tank.
6. Fill water slowly through the radiator cap. Push the upper/lower hoses of the radiator so as to bleed air easily.
7. Warm the engine until the cooling fan operates 2~3 times.  
Accelerate the engine 2~3 times without load.
8. Wait until the engine is cold.
9. Repeat the steps 1~8 until the water drained is clean.
10. Fill fluid mixture with coolant and water(4 : 6) slowly through the radiator cap. Push the upper/lower hoses of the radiator so as to bleed air easily.
11. Start the engine and run so coolant circulates.  
When the cooling fan operates and coolant circulates, refill coolant through the radiator cap.
12. Repeat 11 until the cooling fan cycles 3 ~ 5 times and bleed air sufficiently out of the cooling system.
13. Install the radiator cap and fill the reservoir tank to the "MAX"(or "F") line with coolant.
14. Run the vehicle under idle until the cooling fan operates 2 ~ 3 times.
15. Stop the engine and wait until coolant gets cool.
16. Repeat 10 to 15 until the coolant level doesn't fall any more, bleeding air out of the cooling system.

### 📌NOTICE

Check the coolant level again in the reservoir tank for 2 ~ 3 days after replacing coolant.

## CAP TESTING

1. Remove the radiator cap, wet its seal with engine coolant, and install it to a pressure tester.

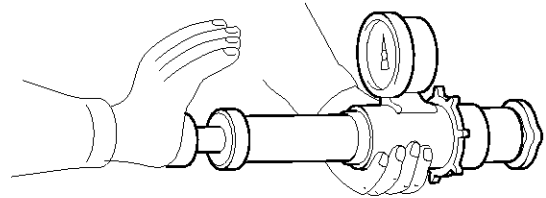

ECKD501X

2. Apply a pressure of 93 ~ 123kPa (0.95 ~ 1.25kgf/cm<sup>2</sup>, 14 ~ 19psi).
3. Check for a drop in pressure.
4. If the pressure drops, replace the cap.

## REMOVAL

### WATER PUMP

1. Drain the engine coolant.

### ⚠WARNING

System is under high pressure when the engine is hot. To avoid danger of releasing scalding engine coolant, remove the cap only when the engine is cool.

2. Remove drive belt(A).

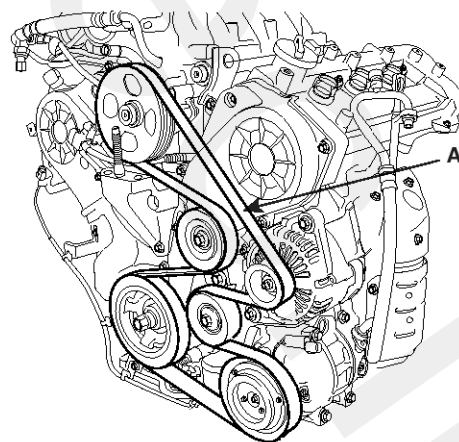



KCBF105A

3. Remove the timing belt.
4. Remove the water pump(A) and gasket(B).

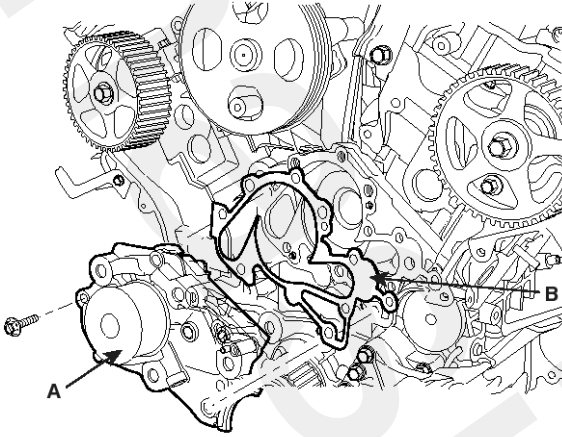

KCBF136A

## WATER TEMPERATURE CONTROL ASSEMBLY

1. Drain the engine coolant.
2. Remove the air cleaner assembly.
3. Disconnect the radiator upper and lower hose(A, B).

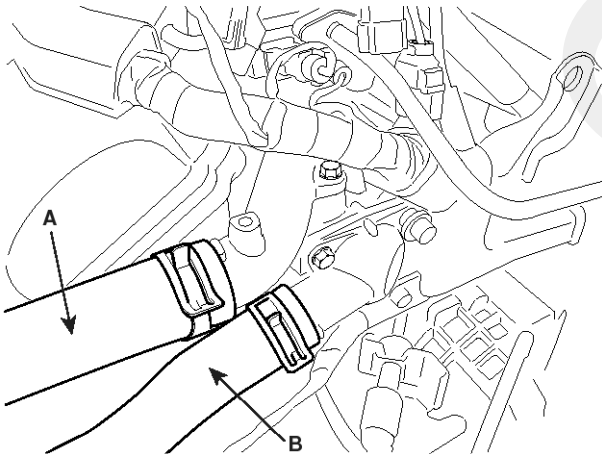

LDLG008A

4. Disconnect the ECT(Engine Coolant Temperature) sensor connector.
5. Remove the coolant hose related to the heater hoses and the ECT(Engine Coolant Temperature) system.
6. Remove wiring protector.
7. Remove water temperature control assembly(A) and the gaskets(B).

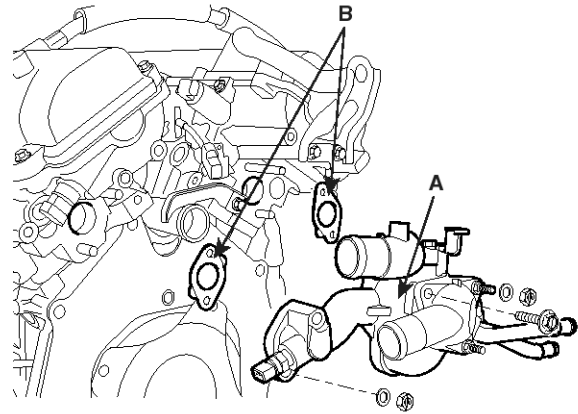

KCBF139A

8. Remove the water pipe(A).

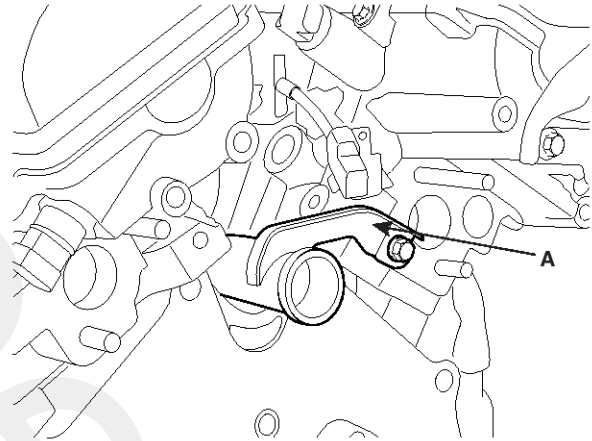

KCBF140A

## THERMOSTAT

### NOTICE

Removal of the thermostat would have an adverse effect, causing a lowering of cooling efficiency. Do not remove the thermostat, even if the engine tends to overheat.

1. Drain engine coolant so its level is below thermostat.
2. Remove the coolant inlet pitting(A) and the thermostat(B).

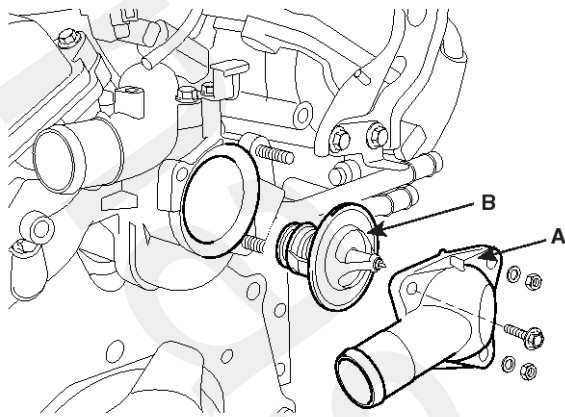

KCBF141A

## RADIATOR

1. Drain the engine coolant.
2. Remove the radiator grille upper cover(A).

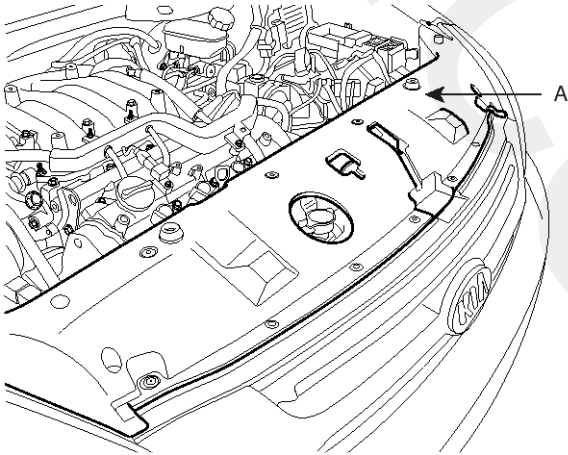

SVQM16002L

3. Remove the radiator support upper member assembly(A) for convenience sake.

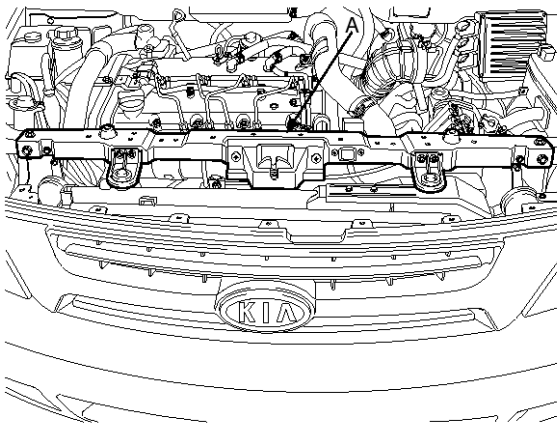

ACKF047A

## NOTICE

The bottom side bolt(A) which can be seen after removing the under cover should be loosened for removal of the radiator support upper member assembly.

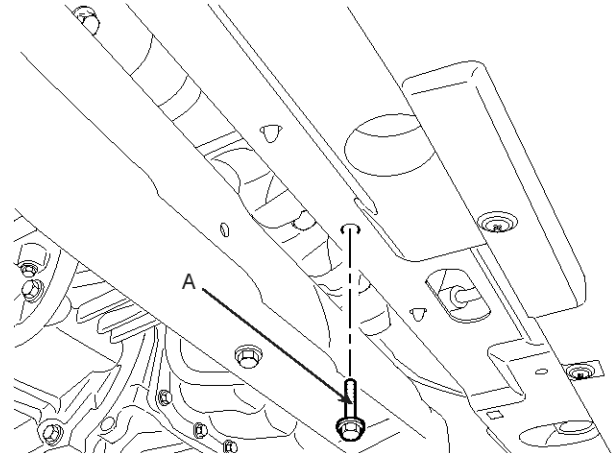

BCKG010A

4. Remove the radiator upper and the lower hoses(A).

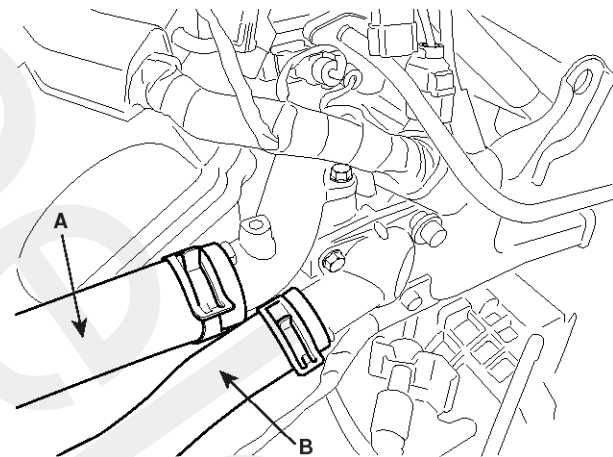

LDLG008A

5. Disconnect transaxle oil cooler hoses(A). (Refer to TR group)

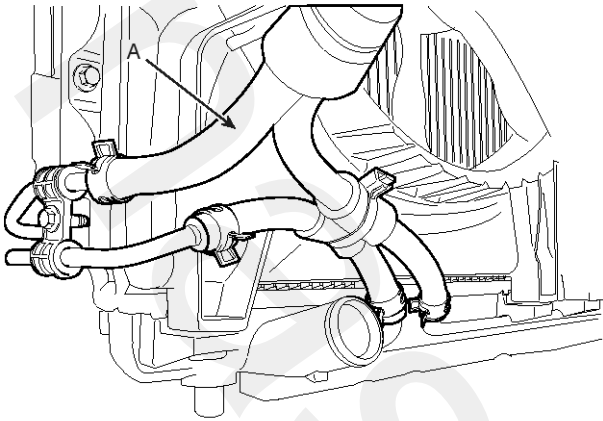

BCKG015A

6. Disconnect the radiator fan connectors(A,B).

LH

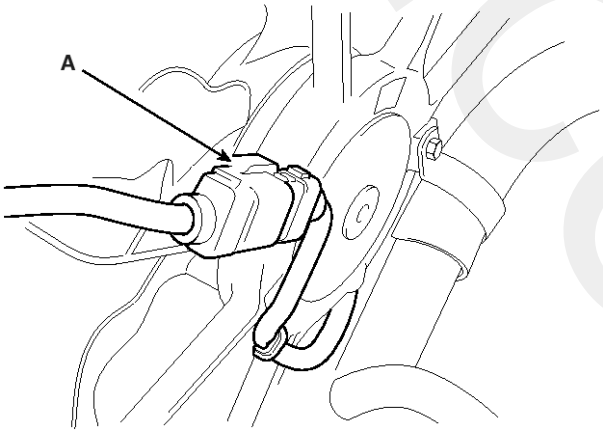

SCMEM6036D

RH

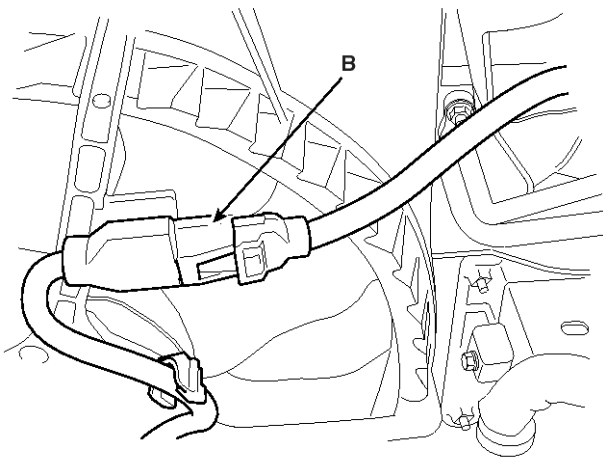

SCMEM6037D

7. Remove the radiator bracket(A, B) and the bleeder hose(C).

LH

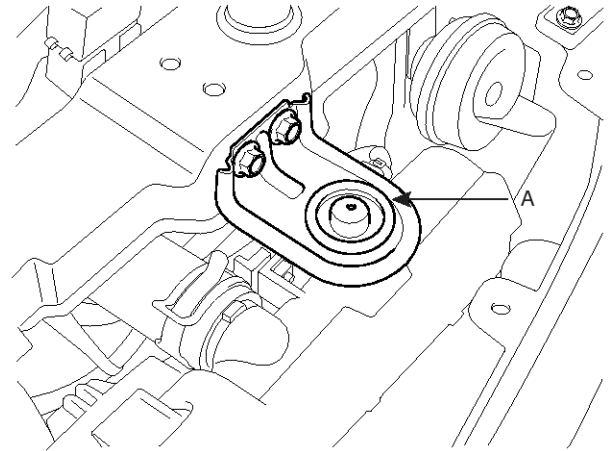

SVQM16004L

RH

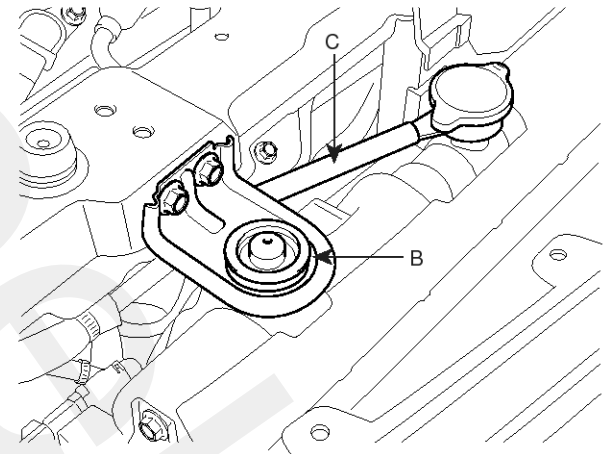

SVQM16003L

8. Separate the condenser from the radiator assembly by removing the bolts.

9. Remove the radiator assembly.

10. Remove the radiator cooling fan.

## INSPECTION

### WATER PUMP

1. Check each part for cracks, damage or wear, and replace the coolant pump assembly if necessary.
2. Check the bearing for damage, abnormal noise and sluggish rotation, and replace the coolant pump assembly if necessary.
3. Check for coolant leakage. If coolant leaks from hole, the seal is defective. Replace the coolant pump assembly.

#### NOTICE

A small amount of "weeping" from the bleed hole is normal.

### THERMOSTAT

1. Immerse the thermostat in water and gradually heat water.

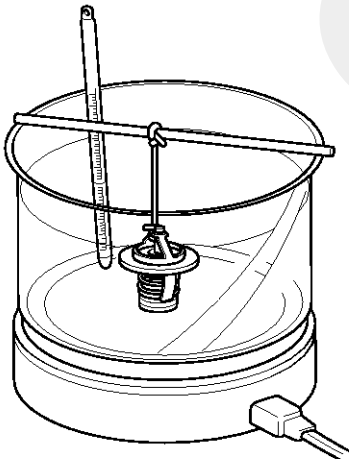

ECKD503B

2. Check the valve opening temperature.  
Valve opening temperature : 82°C (177°F)  
Full opening temperature : 95°C (205°F)  
If the valve opening temperature is not as specified, replace the thermostat.
3. Check the valve lift.  
Valve lift : Min. 10mm (0.4in.) at 95°C (205°F)  
If the valve lift is not as specified, replace the thermostat.

## INSTALLATION

### WATER PUMP

1. Install the water pump(A) and a new gasket(B) with the bolts.

#### Tightening torque

14.7 ~ 21.6Nm (1.5 ~ 2.2kgf.m, 10.8 ~ 15.9lb-ft)

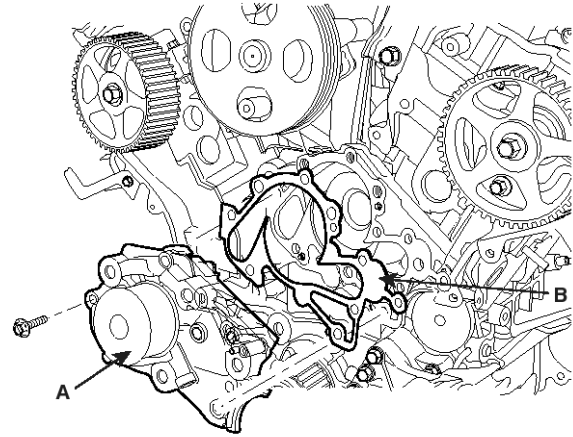

KCBF136A

#### NOTICE

Clean the contacting face before assembling.

2. Install the timing belt.
3. Install drive belt(A).

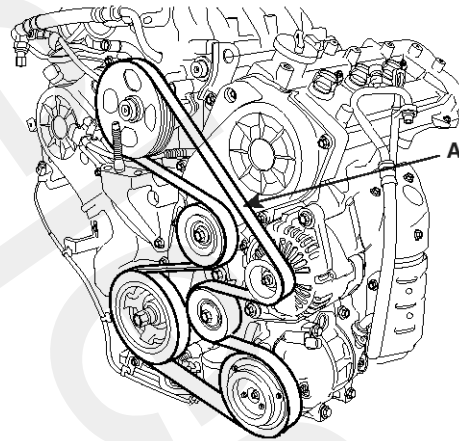

KCBF105A

4. Fill with engine coolant.
5. Start engine and check for leaks.
6. Recheck engine coolant level.

## WATER TEMPERATURE CONTROL ASSEMBLY

1. Install the water pipe(A).

### Tightening torque

16.7 ~ 19.6Nm (1.7 ~ 2.0kgf.m, 12.3 ~ 14.5lb-ft)

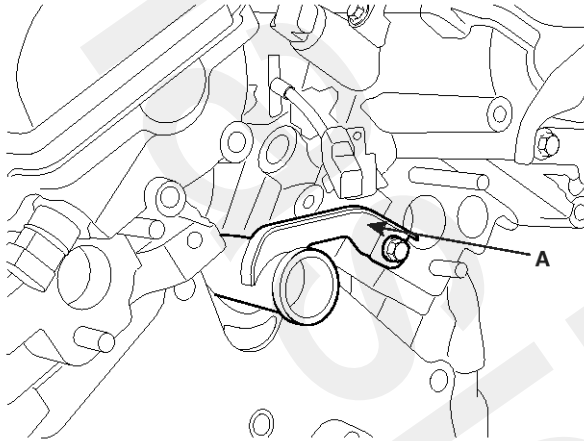

KCBF140A

2. Install the water temperature control assembly(A) with a new gasket(B).

### Tightening torque

29.4 ~ 41.2Nm(3.0 ~ 4.2kgf.m, 21.7 ~ 30.4lb-ft)

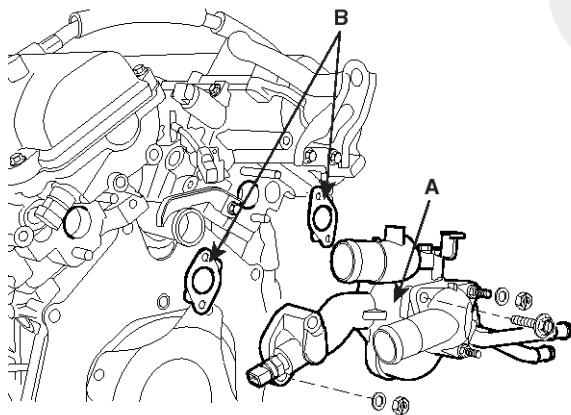

KCBF139A

### NOTICE

Use new O-rings and wet them with water or coolant when reassembling.

3. Install the wiring protector.
4. Connect the heater hose and ECT hose.
5. Connect the ECT sensor connector.
6. Connect the radiator upper and the lower hose(A).

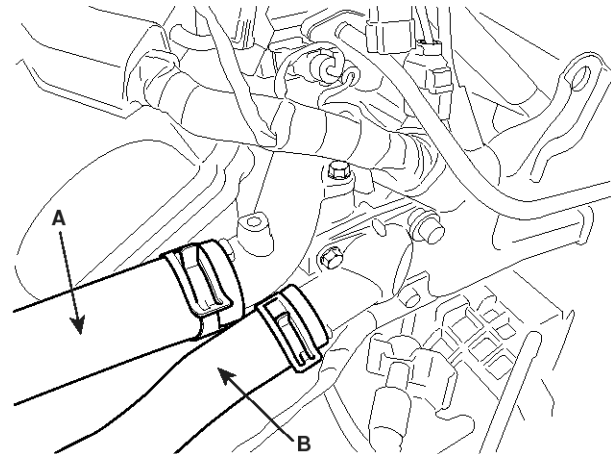

LDLG008A

7. Install the air cleaner assembly.
8. Fill with engine coolant.
9. Start engine and check for leaks.
10. Recheck engine coolant level.

## THERMOSTAT

1. Place thermostat(B) in coolant inlet pitting(A).  
Install the thermostat with the jiggle valve upward.

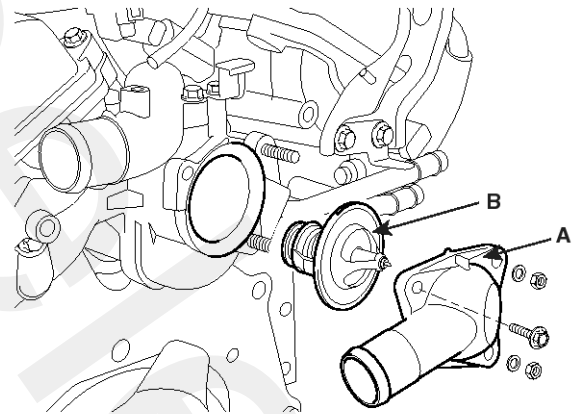

KCBF141A

2. Install the coolant inlet pitting(A).

### Tightening torque

16.66 ~ 19.60Nm (1.7 ~ 2.0kgf.m, 12.30 ~ 14.47lb-ft)

3. Fill with engine coolant.
4. Start engine and check for leaks.

## RADIATOR

1. Install the radiator fan(A) to the radiator.

### Tightening torque

4.9 ~ 7.8Nm (0.5 ~ 0.8kgf.m, 3.6 ~ 5.8lb-ft)

2. Install the radiator assembly to the vehicle.
3. Fix the condenser with the radiator assembly.

## Tightening torque

4.9 ~ 7.8Nm (0.5 ~ 0.8kgf.m, 3.6 ~ 5.8lb-ft) - D

6.9 ~ 9.8Nm (0.7 ~ 1.0kgf.m, 5.1 ~ 7.2lb-ft) - C

4. Install the radiator bracket(A, B) and the bleeder hose(C).

LH

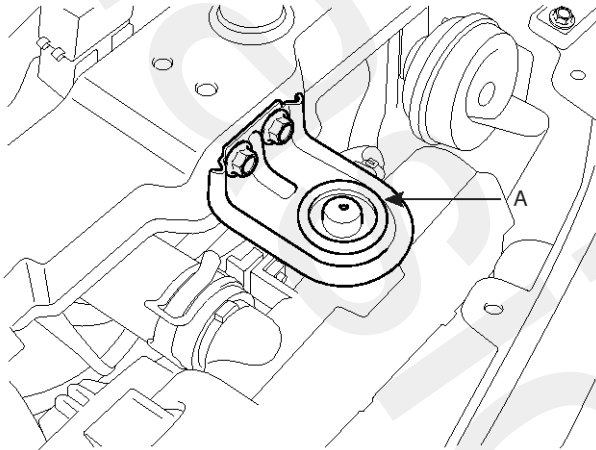

SVQM16004L

RH

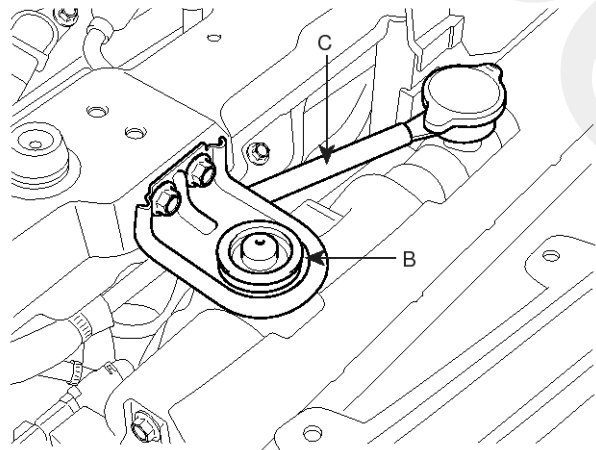

SVQM16003L

5. Connect the radiator fan connectors(A,B)

LH

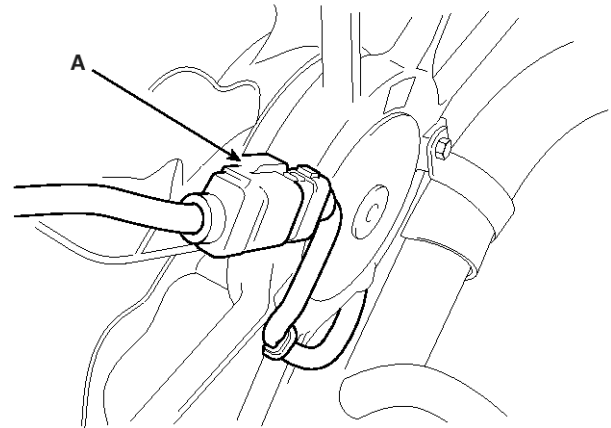

SCMEM6036D

RH

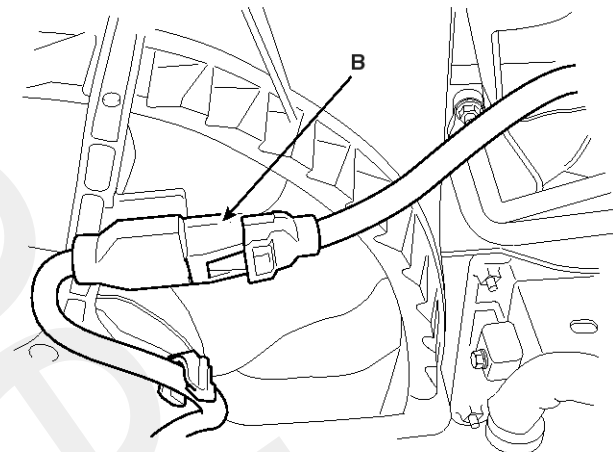

SCMEM6037D

6. Install the transaxle oil cooler hoses(A).(Refer to TR group)

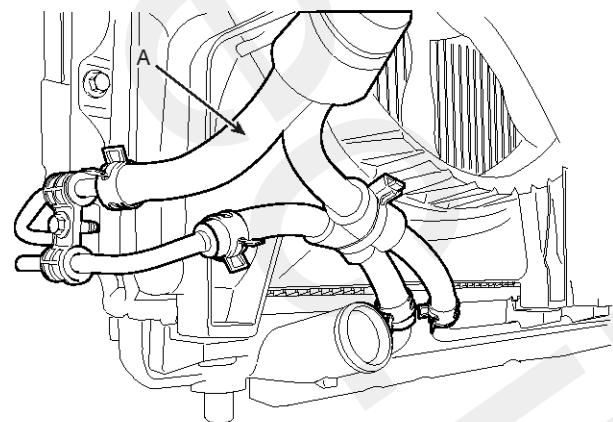

BCKG015A

7. Install the radiator upper(A) and lower hoses(B).

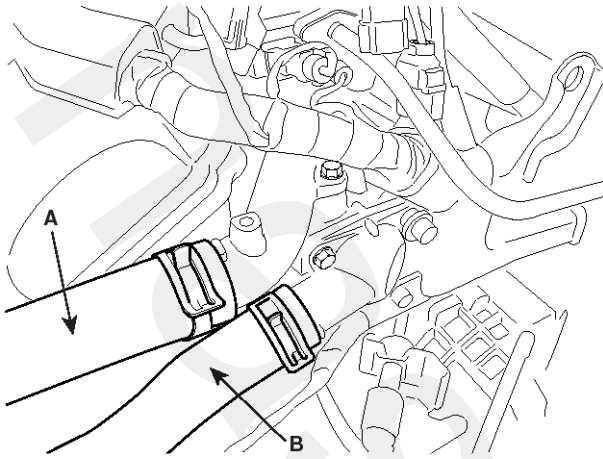

LDLG008A

8. Install the radiator support upper member assembly(A).

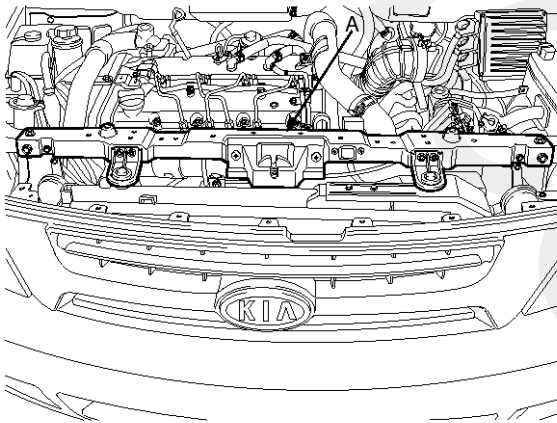

ACKF047A

9. Install the radiator grille upper cover(A).

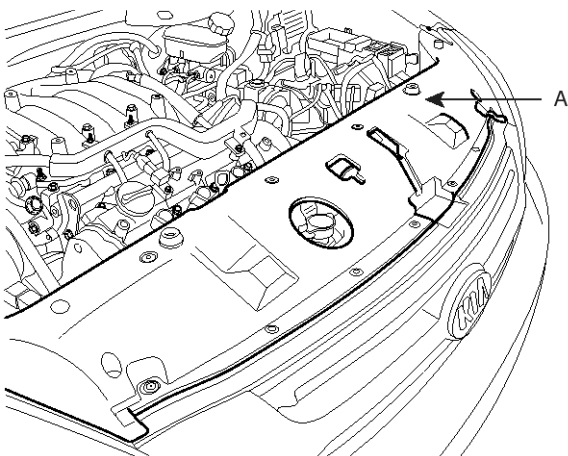

SVQM16002L

10. Fill with engine coolant.
11. Start engine and check for leaks.

12. Recheck engine coolant level.

## Lubrication System COMPONENTS

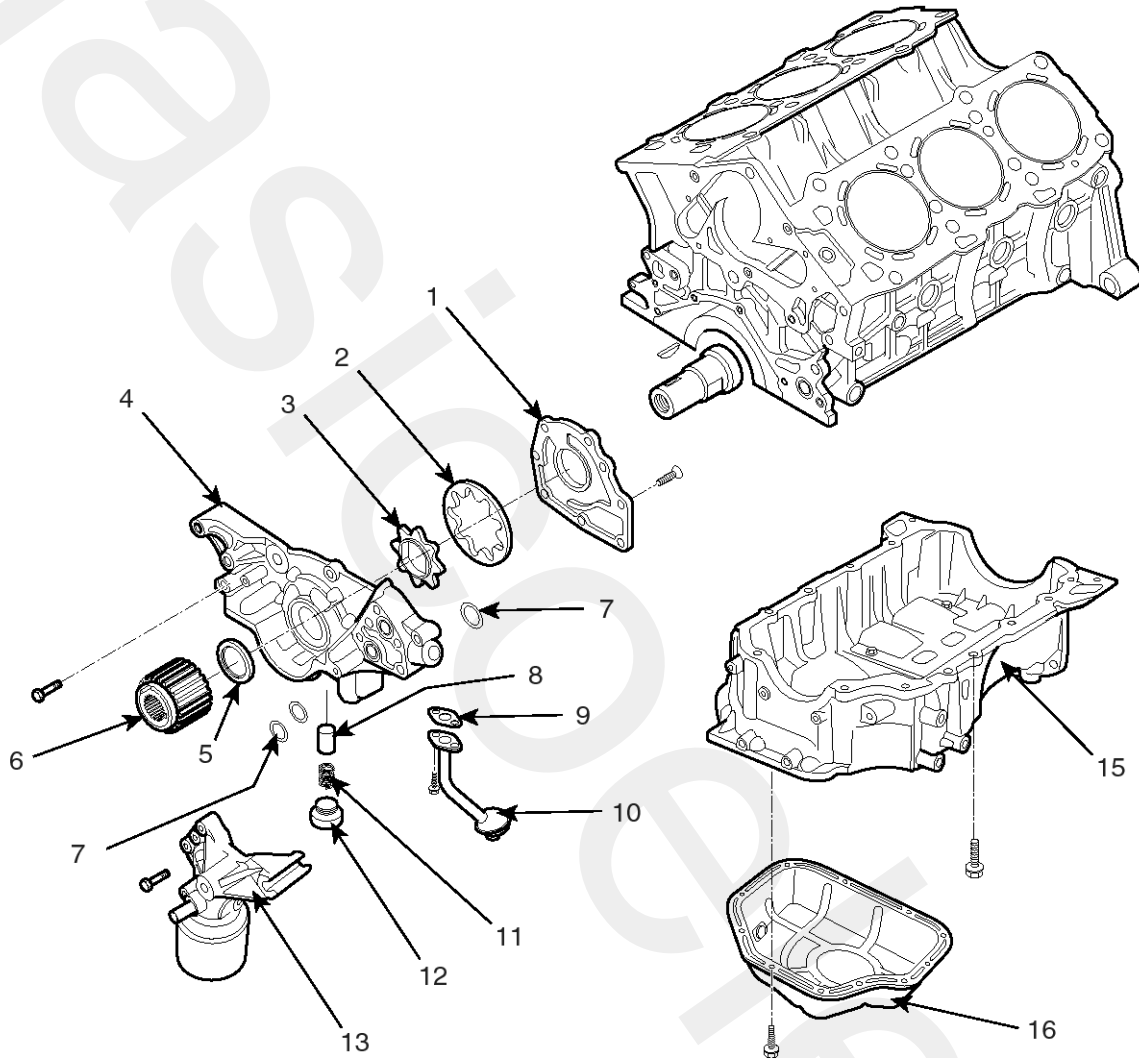

1. Oil pump cover
2. Oil pump outer rotor
3. Oil pump inner rotor
4. Oil pump case rotor
5. Oil seal
6. Crankshaft sprocket
7. O-ring
8. Relief plunger
9. Oil screen gasket
10. Oil screen
11. Relief spring
12. Plug
13. Oil filter bracket
15. Upper oil pan
16. Lower oil pan



## REPLACEMENT OIL AND FILTER

### ⚠ CAUTION

- Prolonged and repeated contact with mineral oil will result in the removal of natural fats from the skin, leading to dryness, irritation and dermatitis. In addition, used engine oil contains potentially harmful contaminants which may cause skin cancer.
  - Wear protective clothing and gloves in order to minimize the length and frequency of contact of your skin to used oil. Wash your skin thoroughly with soap and water, or use water-less hand cleaner, to remove any used engine oil. Do not use gasoline, thinners, or solvents.
  - In order to preserve environment, used oil or used oil filter must be disposed only at designated disposal sites.
1. Park the car on a level ground.  
Start the engine and let it warm up.
  2. Turn the engine off.
  3. Drain engine oil.
    - 1) Remove the oil filler cap.
    - 2) After lifting the car, remove the oil drain plug(A) and drain oil into a container.
  4. Replace the oil filter.
    - 1) Remove the oil filter(B).

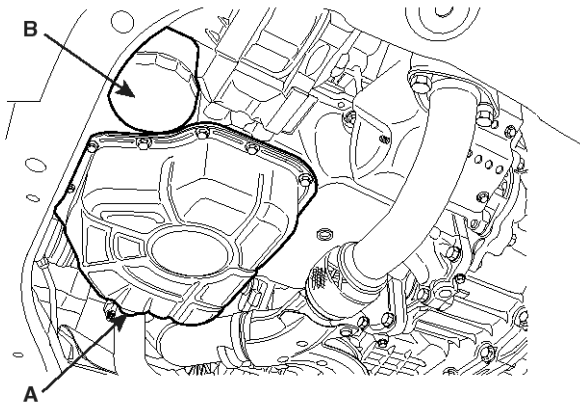

SCMEM6003L

- 2) Check the part number of a new oil filter is as the same as that of the old one.
- 3) Replace the oil filter.
- 4) Tighten it slightly until the o-ring of the filter cap contacting on its position.
- 5) Tighten it with the specified torque.

### Tightening torque

16.7 ~ 24.5Nm(1.7 ~ 2.5kgf.m, 12.3 ~ 18.1lb-ft)

5. Refill with engine oil.
  - 1) Install the oil drain plug with a new gasket.

### Tightening torque

34.3 ~ 44.1Nm (3.5 ~ 4.5kgf.m, 25.3 ~ 32.5lb-ft)

- 2) Fill with fresh engine oil, after removing the engine oil level gauge.

### Capacity

Total : 4.8 L (5.07 US qt, 4.22 Imp qt)

Oil pan : 4.2 L (4.43 US qt, 3.69 Imp qt)

Drain and refill including oil filter : 4.5 L (4.75 US qt, 3.95 Imp qt)

Oil quality : ABOVE API SJ / SL or SAE 5W-20

- 3) Install the oil filler cap and the oil level gauge.
6. Start the engine and ensure that no oil is leaking from the drain plug or the oil filter.
7. Recheck engine oil level.

## REMOVAL

### Oil pump case

1. Drain engine oil.
2. Remove the front right wheel and tire.
3. Remove the front right side cover.
4. Remove the front muffler.
5. Remove the generator.
6. Remove the timing belt.
7. Remove the oil filter bracket(A).

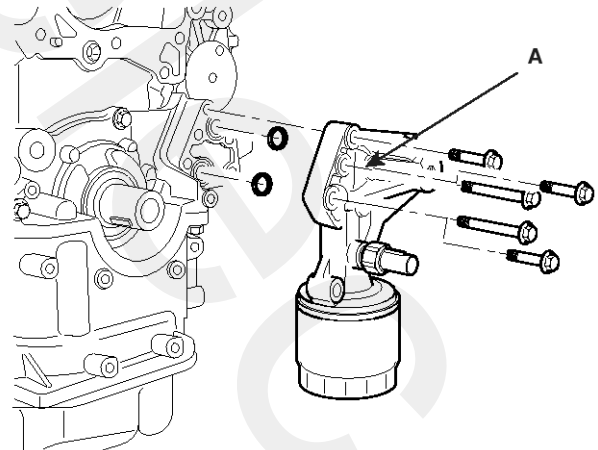

KCBF147A

8. Using SST(09215-3C000), remove the lower oil pan(A).

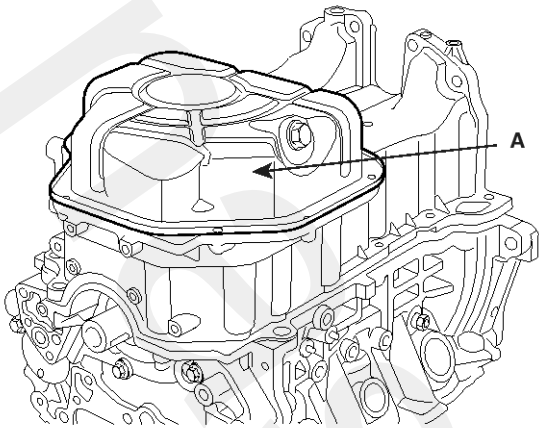

KCBF123A

**CAUTION**

Be careful not to damage the contact surfaces of upper oil pan and lower oil pan.

9. Remove the oil screen(A).

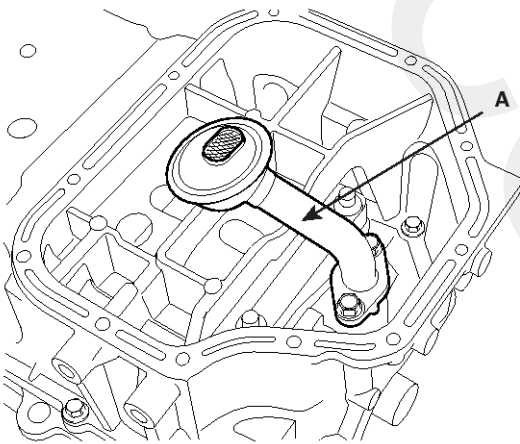

KCBF124A

10. Remove the upper oil pan, using the SST(09215-3C000)(A).

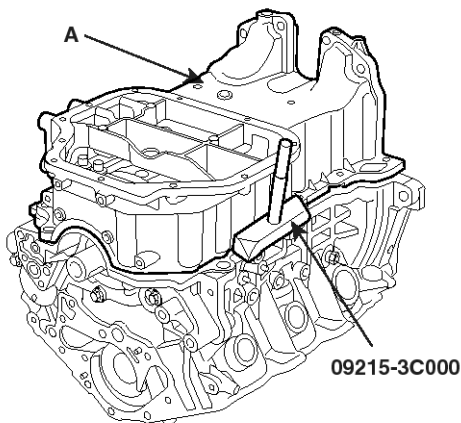

KCBF125B

**CAUTION**

Be careful not to damage the contact surfaces of upper oil pan and lower oil pan.

11. Remove the oil pump case(A).

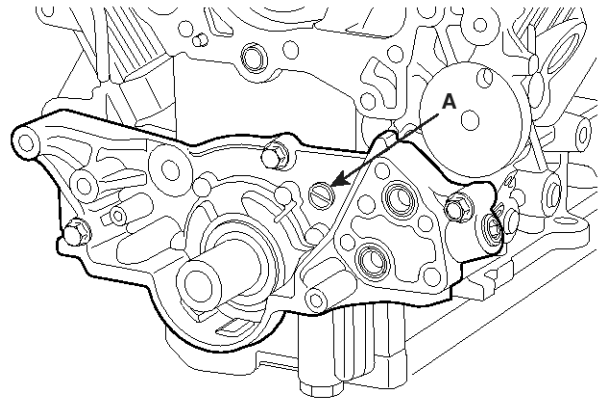

KCBF163A

12. After removing the plug(A), remove the relief spring(B) and the relief plunger(C).

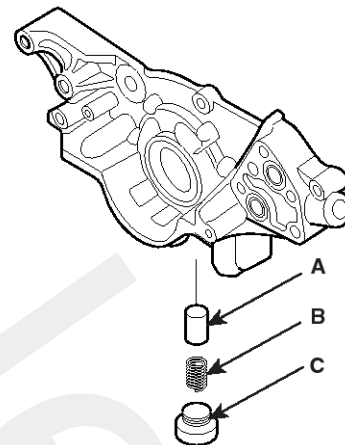

KCBF163C

## INSPECTION

1. Check engine oil quality.  
Check the oil for deterioration, entry of water, discoloring or thinning.  
If the quality is visibly poor, replace oil.
2. Check the engine oil level.  
After warming up the engine, make the engine stand still for five minutes or more. The oil level should be between the 'L' and 'F' marks on the dipstick, then.  
If low, check for leakage and add oil up to the "F" mark.

### NOTICE

Do not fill with engine oil above the "F" mark.

## SELECTION OF ENGINE OIL

Recommended API classification : Above SJ or SL

Recommended SAE viscosity grades : 5W-20

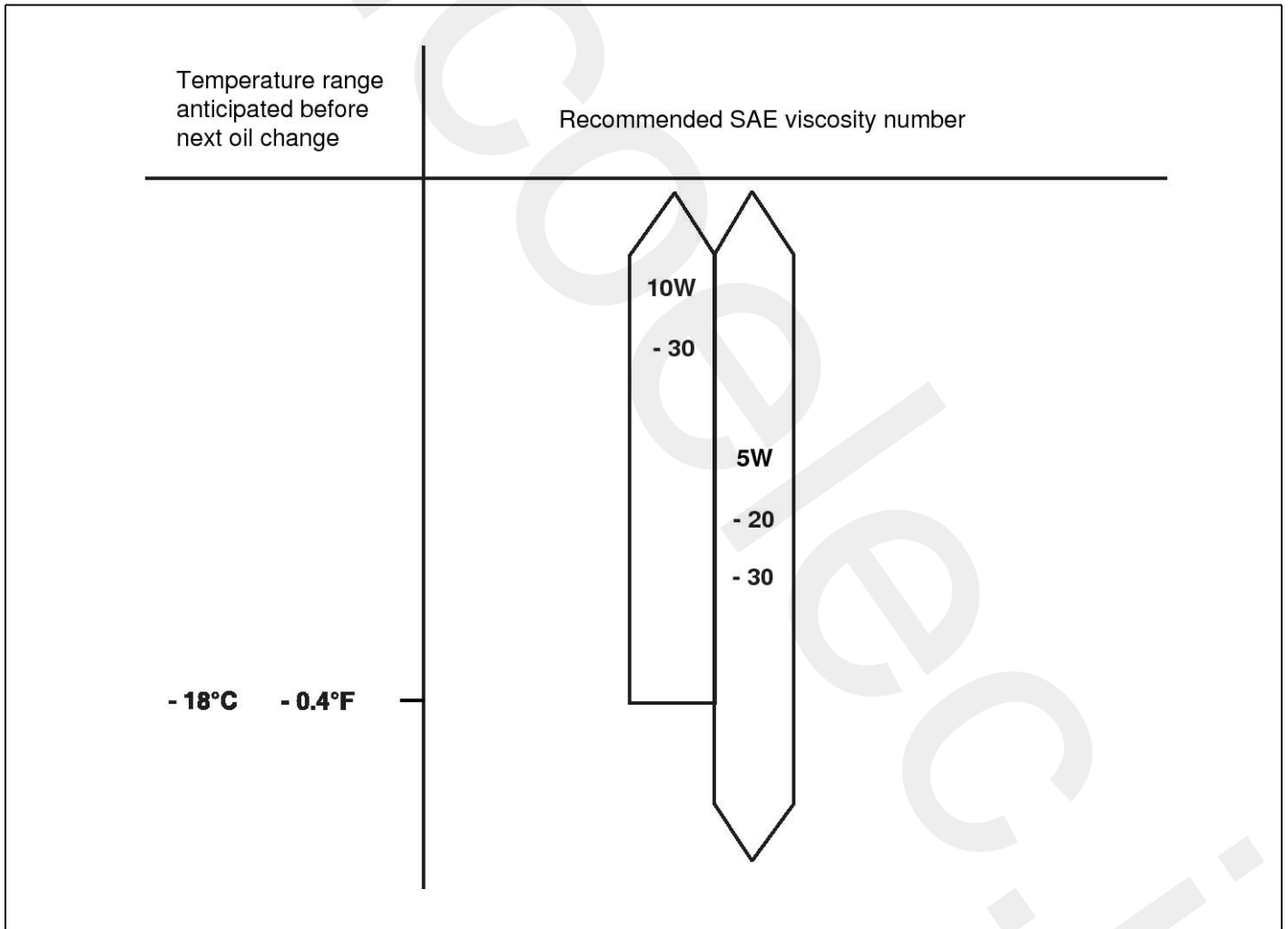

## NOTICE

For best performance and maximum protection of all types of operation, select only those lubricants which :

- Satisfy the requirement of the API classification.
- Have proper SAE grade number for expected ambient temperature range.

Lubricants that do not have both an SAE grade number and API service classification on the container should not be used.

## RELIEF SPRING

1. Check the relief plunger.

Apply engine oil on the plunger and check that it moves smoothly in the hole. If it does not, replace the plunger or the front case only in necessary cases.

2. Check the relief valve spring.

Check deformation or damage of the relief valve spring.

## Specification

Free length : 43.8mm(1.7244in.)

Load : 36.3N(3.7kg, 8.21lb)±3.9N(0.4kg, 0.9lb) / 40.1mm(1.5787in.)

## OIL PRESSURE SWITCH

1. Check the continuity between the terminal and the body with an ohmmeter.

If there is no continuity, replace the oil pressure switch.

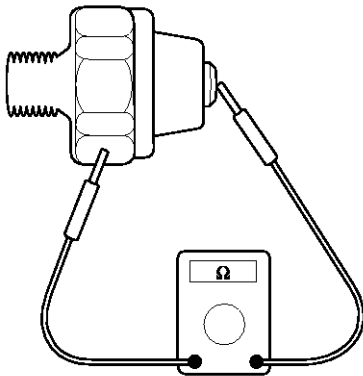

ECKD001W

2. Check the continuity between the terminal and the body when its hole is pushed by a fine rod(A). If there is continuity with pressed, replace the switch.

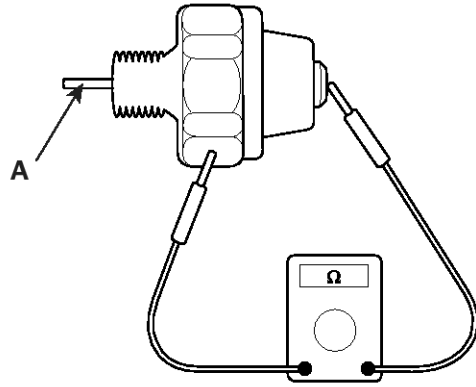

LDLG052A

3. If there is no continuity when the pressure 49.3kpa (0.5kg/cm<sup>2</sup>, 7.11psi) is applied through the oil hole, the switch is operating properly.

Check for air leakage. If air leaks, the diaphragm is broken. Replace the switch.

## INSTALLATION

### Oil pump case

1. Assemble the relief spring(B) and the relief plunger(C) and tighten the plug(A).

### Tightening torque

39.2 ~ 49.0Nm (4.0 ~ 5.0kgf.m, 28.9 ~ 36.2lb-ft)

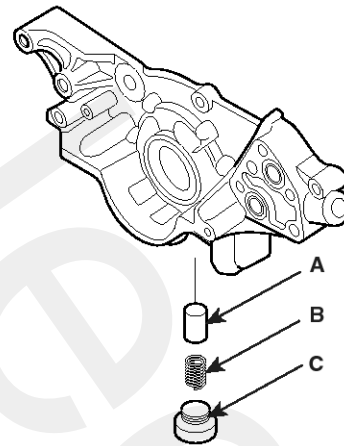

KCBF163C

2. Install oil pump case.

- 1) Using a gasket scraper, remove all the old packing material from the gasket surfaces.
- 2) Before assembling the oil pan, the liquid sealant TB1217H should be applied on the oil pan.

The part must be assembled within 5 minutes after the sealant was applied.

Bead width : 2.5mm(0.0984in.)

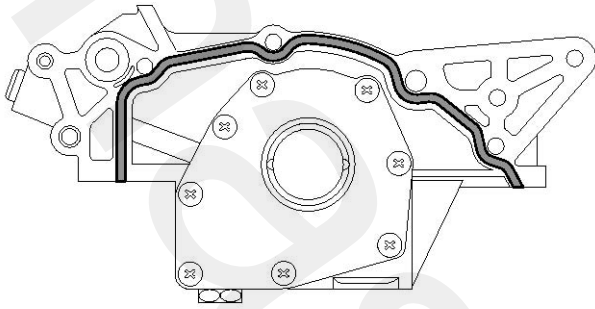

KCBF134A

**CAUTION**

- Make clean the sealing face before assembling two parts.
- Remove harmful foreign materials on the sealing face before applying sealant.
- When applying sealant gasket, sealant must not be protrude into the inside of oil pan.
- To prevent leakage of oil, apply sealant gasket to the inner threads of the bolt holes.
- After assembly, wait at least 30 minutes before filling the engine with oil.

3) Install the oil pump case(A).

**Tightening torque**

18.6 ~ 23.5(1.9 ~ 2.4kgf.m, 13.7 ~ 17.4lb-ft)

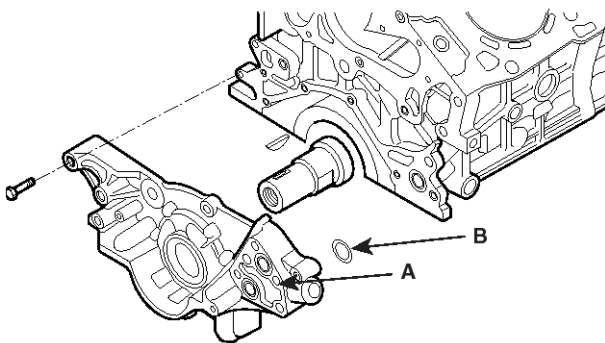

LDLG070A

**CAUTION**

In the installation of the oil pump, always use a new o-ring(B).

3. Using the SST(09214~33000), install the oil pump case oil seal.

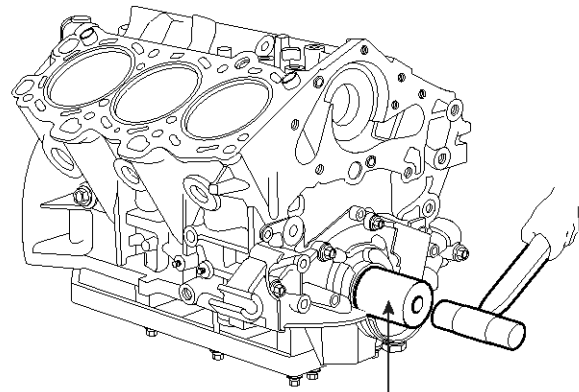

09214-33000

EDQF189A

4. Install the upper oil pan.

- 1) Using a gasket scraper, remove all the old packing material from the gasket surfaces.
- 2) Before assembling the oil pan, the liquid sealant TB1217H should be applied on the oil pan.

The part must be assembled within 5 minutes after the sealant was applied.

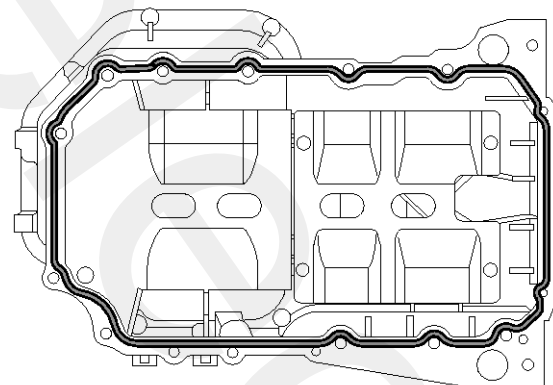

KCBF130A

**CAUTION**

- Make clean the sealing face before assembling two parts.
- Remove harmful foreign materials on the sealing face before applying sealant.
- When applying sealant gasket, sealant must not be protrude into the inside of oil

pan.

- To prevent leakage of oil, apply sealant gasket to the inner threads of the bolt holes.
- After assembly, wait at least 30 minutes before filling the engine with oil.

3) Fix the oil pan and tighten the bolts in several steps uniformly.

### Tightening torque

Bolts 1~15 : 18.6 ~ 23.5Nm(1.9 ~ 2.4kgf.m, 13.7 ~ 17.4lb-ft)

Bolts 16,17 : 4.9 ~ 6.9Nm(0.5 ~ 0.7kgf.m, 3.6 ~ 5.1lb-ft)

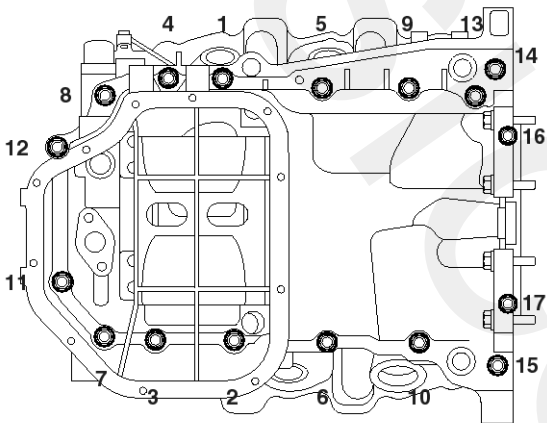

KCBF131A

5. Install the oil screen.

### Tightening torque

14.7 ~ 21.6Nm(1.5 ~ 2.2kgf.m, 10.8 ~ 15.9lb-ft)

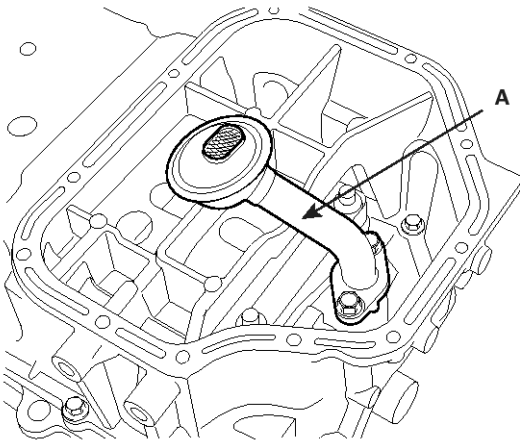

KCBF124A

### NOTICE

Always use a new gasket.

6. Install the lower oil pan.

- 1) Using a gasket scraper, remove all the old packing material from the gasket surfaces.
- 2) Before assembling the oil pan, the liquid sealant TB1217H should be applied on the oil pan.

The part must be assembled within 5 minutes after the sealant was applied.

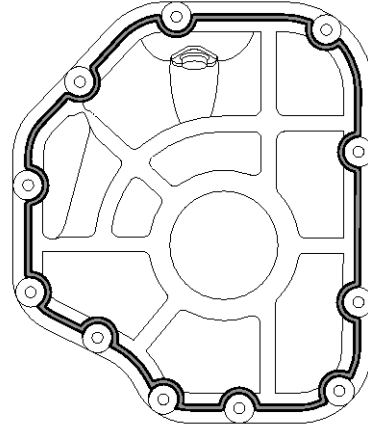

KCBF132A

### CAUTION

- Make clean the sealing face before assembling two parts.
- Remove harmful foreign materials on the sealing face before applying sealant.
- When applying sealant gasket, sealant must not be protrude into the inside of oil pan.
- To prevent leakage of oil, apply sealant gasket to the inner threads of the bolt holes.
- After assembly, wait at least 30 minutes before filling the engine with oil.

3) Fix the oil pan and tighten the bolts in several steps uniformly.

### Tightening torque

9.8 ~ 11.8Nm(1.0 ~ 1.2kgf.m, 7.2 ~ 8.7lb-ft)

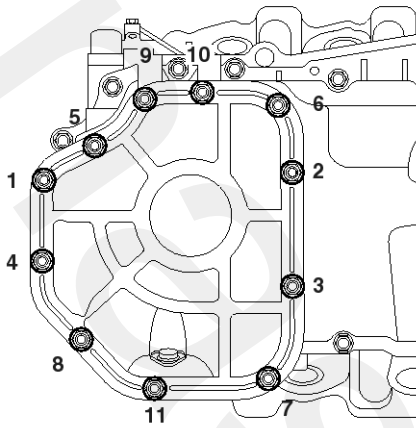

KCBF133A

7. Install the oil filter bracket(A).

#### Tightening torque

18.6 ~ 23.5Nm(1.9 ~ 2.4kgf.m, 13.7~ 17.4lb-ft)

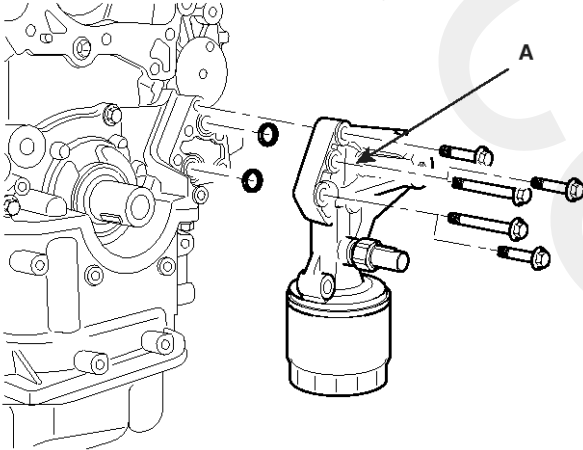

KCBF147A

#### ⚠ CAUTION

**Always use a new O-ring.**

8. Install the timing belt, the generator and the front muffler.
9. Install the front right side cover and the wheel and tire.
10. Fill with engine coolant.
11. Start engine and check for leaks.
12. Recheck engine coolant level.

## Intake And Exhaust System COMPONENTS

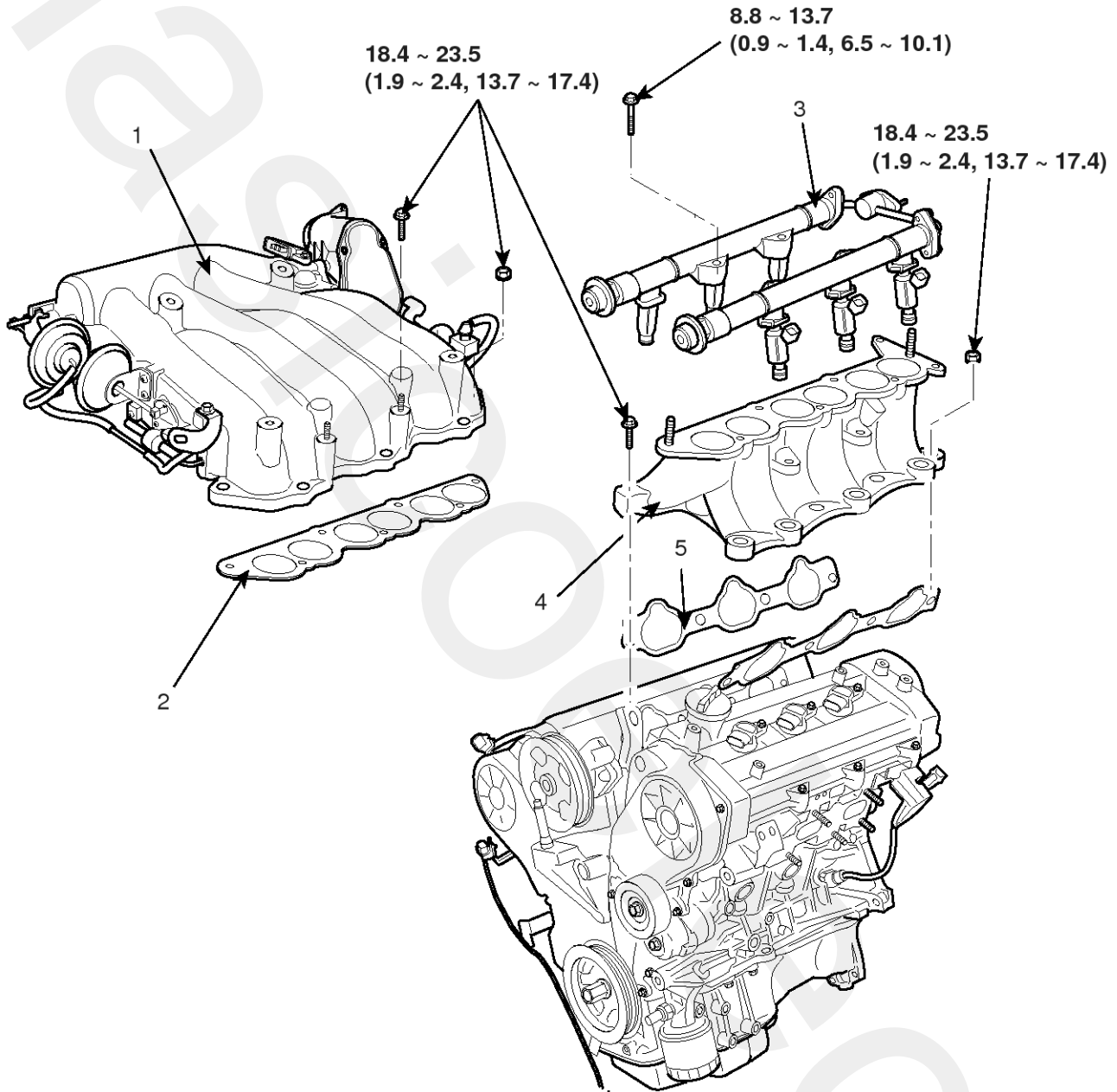

### TORQUE : N.m (kgf.m, lb-ft)

1. Surge tank
2. Surge tank gasket

3. Delivery pipe
4. Intake manifold
5. Intake manifold gasket



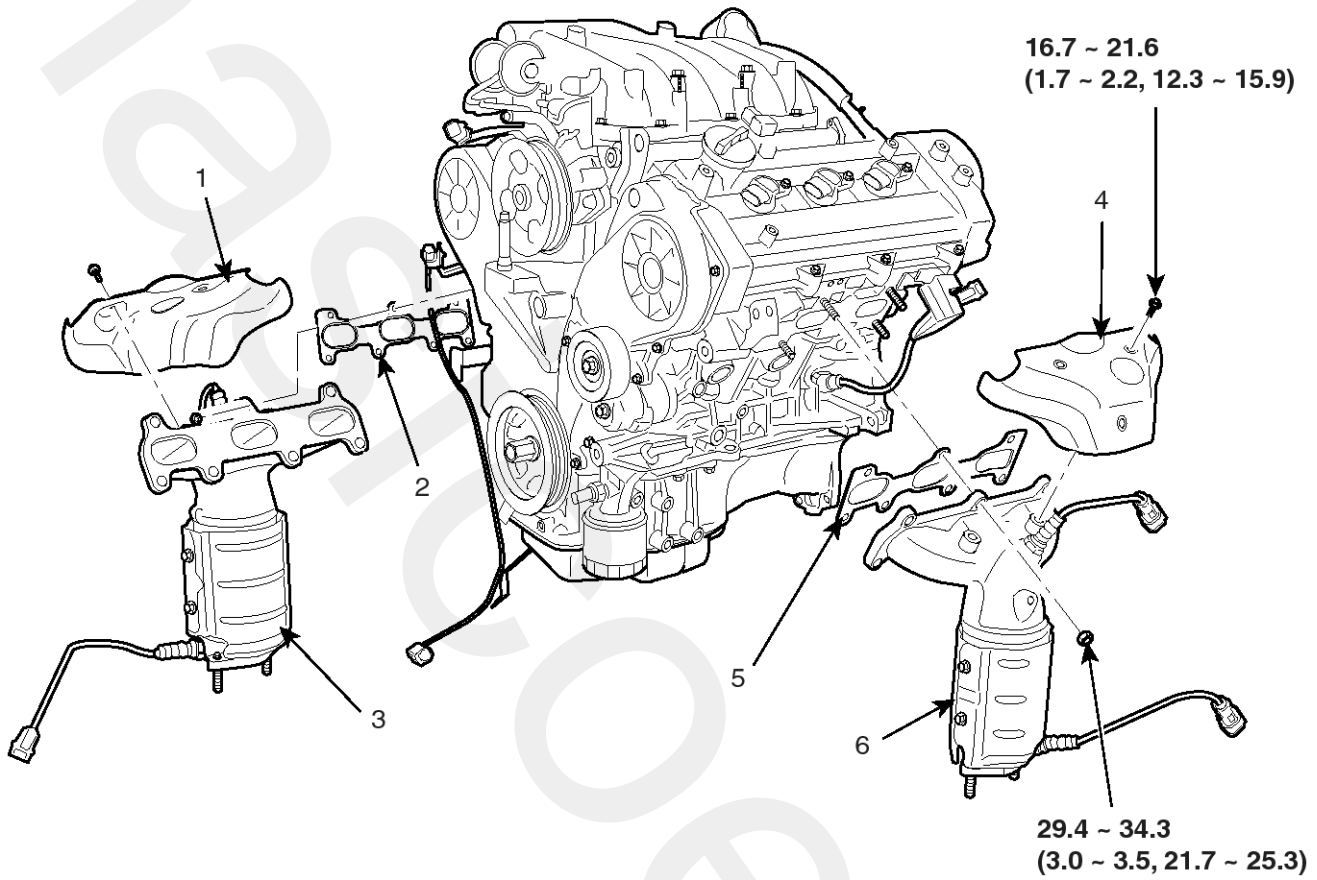

**TORQUE : N.m (kgf.m, lb-ft)**

- 1. Bank 1 heat protector
- 2. Bank 1 exhaust manifold
- 3. Bank 1 exhaust gasket

- 4. Bank 2 protector
- 5. Bank 2 exhaust manifold gasket
- 6. Bank 2 exhaust manifold

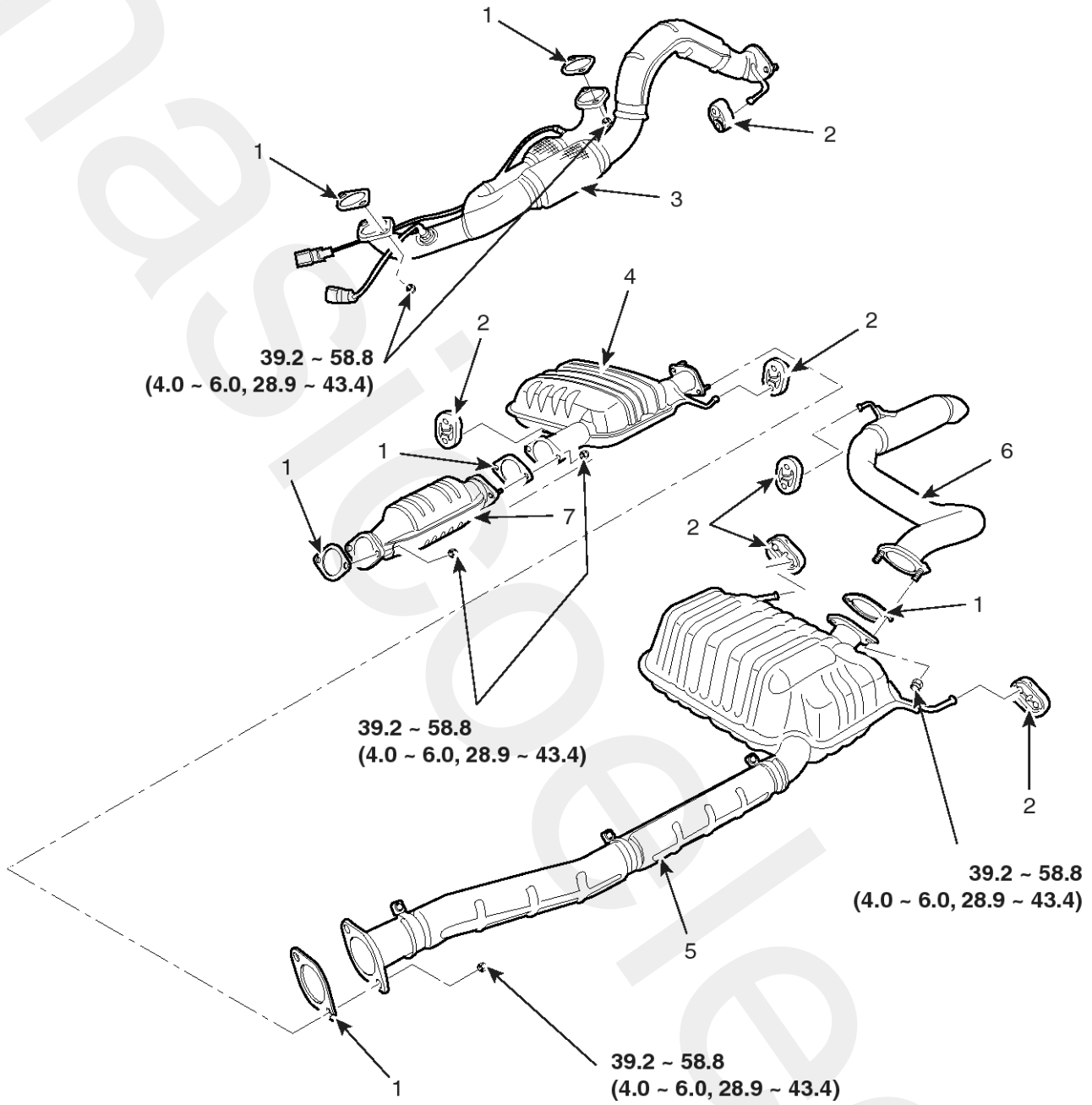

**TORQUE : N.m (kgf.m, lb-ft)**

- 1. Gasket
- 2. Hanger
- 3. Front muffler assembly
- 4. Center muffler assembly

- 5. Main muffler assembly
- 6. Tail pipe muffler assembly
- 7. Catalytic converter assembly

## REMOVAL

### INTAKE MANIFOLD ASSEMBLY

1. Remove the engine cover.
2. Remove the intake air hose and air cleaner assembly.
  - 1) Disconnect the MAF connector(A).
  - 2) Disconnect the breather hose(B) from air cleaner hose.
  - 3) Remove the intake air hose and air cleaner assembly(C).

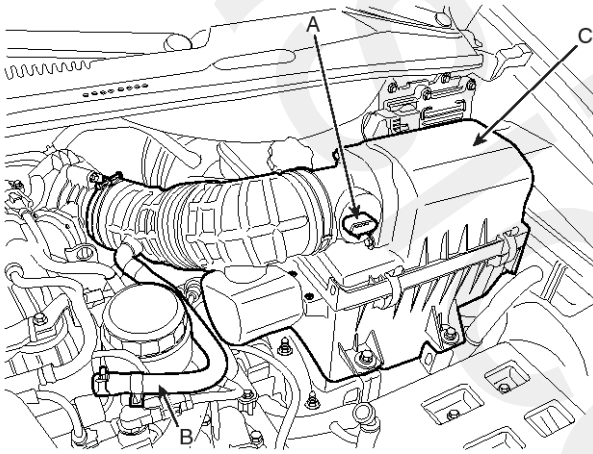

BCKG002A

3. Disconnect the engine wiring harness connectors.
  - 1) Disconnect the No.1/No.2 knock sensor connectors(A,B), the oil pressure switch connector(C), the ignition coil harness(D) and the No.1 VIS(Variable Induction System) connector(E).

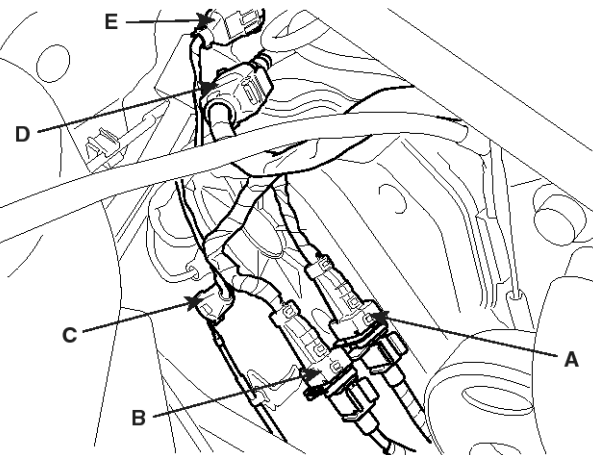

LDLG005A

- 2) Disconnect the bank 1 front/rear O2 sensor connectors(A).

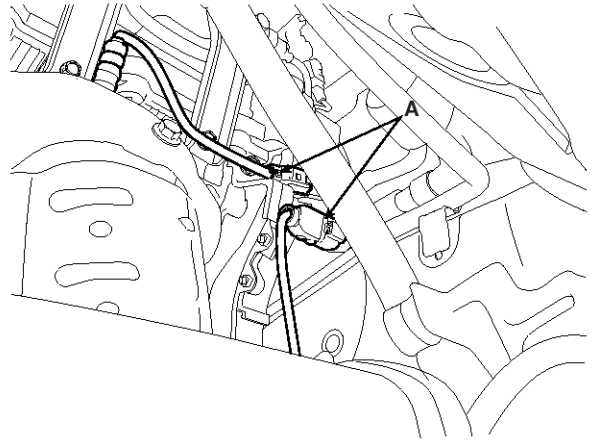

KCBF160A

- 3) Disconnect the injection connectors(A,B,C), the ground lines(D), the condenser connector(E) and the Ignition coil connectors(F).

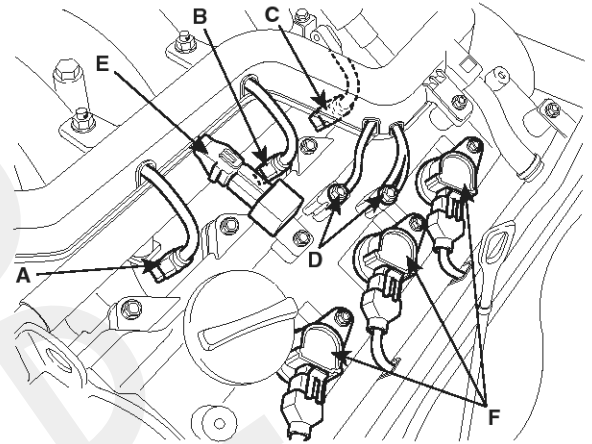

LDLG060A

- 4) Disconnect the injection harness connector(A), the No.2 VIS(Variable Induction System) connector(B), the No.1/No.2 OCV(Oil Control Valve) connectors(C,D) and the OTS(Oil Temperature Sensor) connector(E).

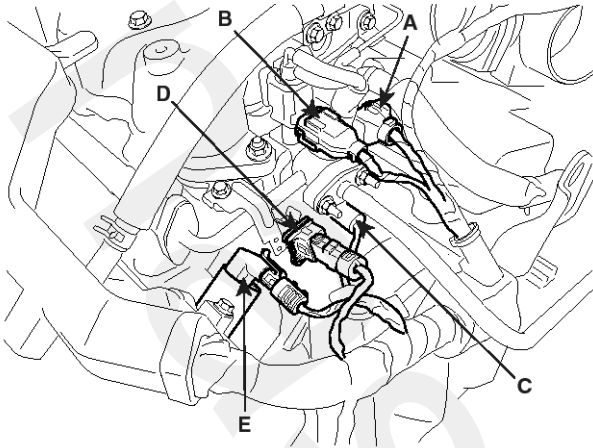

LDLG006A

- 5) Disconnect the MAPS(Manifold Absolute Pressure Sensor) connector(A), the ETC(Electronic Throttle Control) connector(B) and the PCSV(Purge Control Solenoid Valve) connector(C).

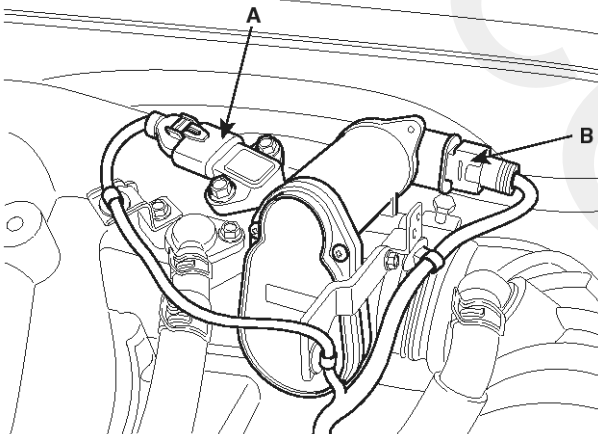

LDLG034A

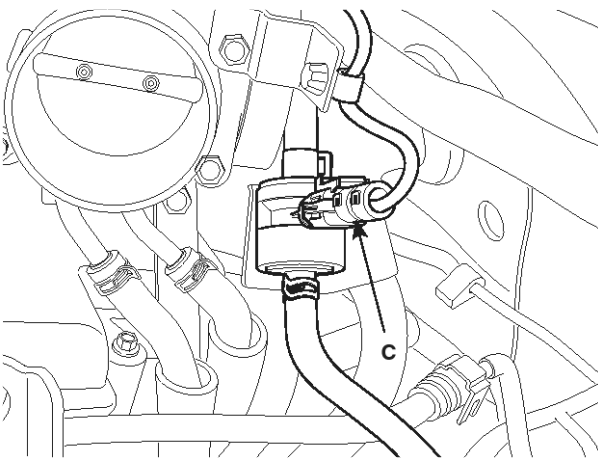

LDLG035A

- 6) Disconnect the generator connector(A) and the air conditioning compressor connector(B).

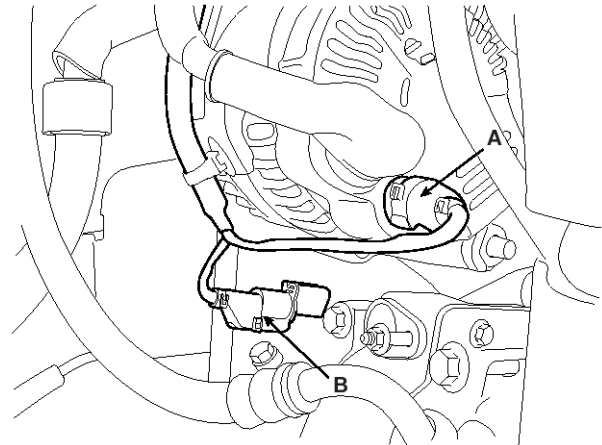

KCBF151A

- 7) Disconnect the bank 2 CMP sensor connector(A) and the ECT(Engine Coolant Temperature) sensor connector(B).

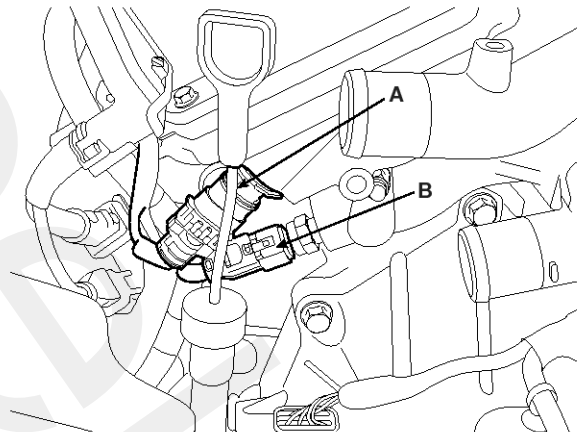

KCBF155A

- 8) Disconnect the bank 2 front/rear O2 sensor connectors(A,B) and the CKP sensor connector(C).

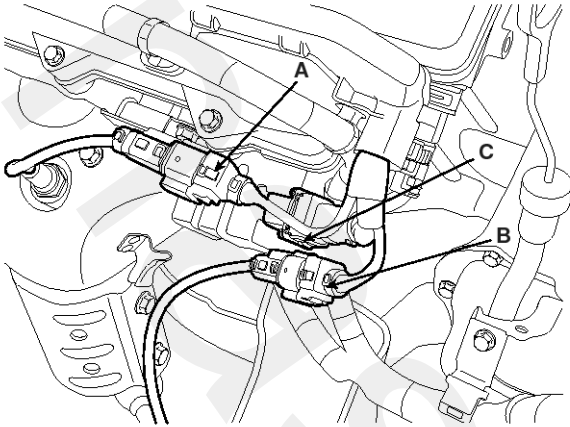

KCBF154A

9) Disconnect the bank 1 CMP sensor connector(A).

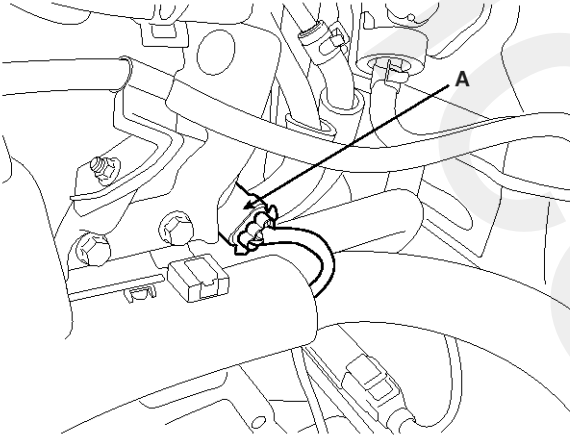

KCBF152A

4. Remove the PCV(Pulse Control Valve) hose(A).

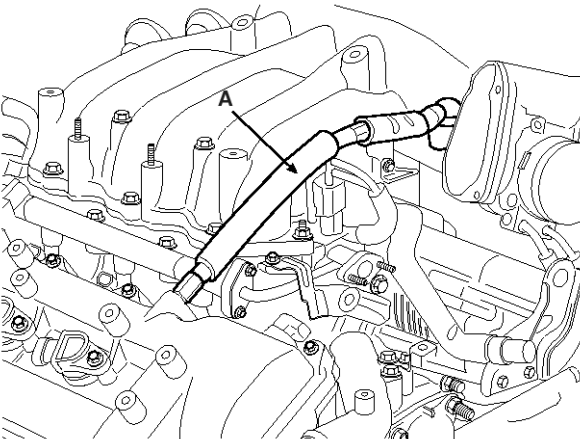

KCBF180A

5. Remove the ETC(Electric Throttle Control) bracket(A) and the cooling hoses(B).

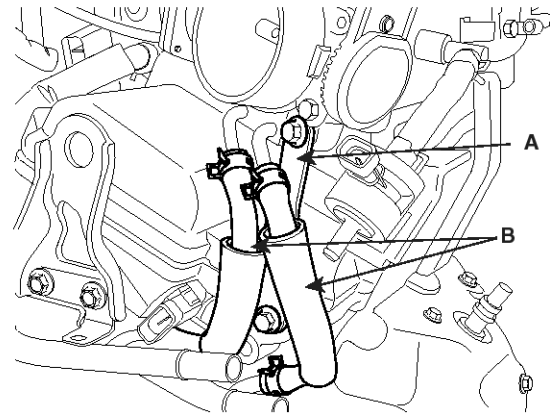

KCBF179A

6. Disconnect the brake vacuum hose(A).

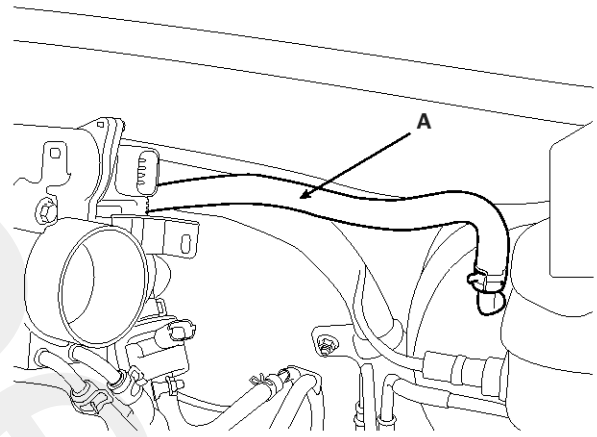

LDLG036A

7. Remove the surge tank mounting bracket(A).

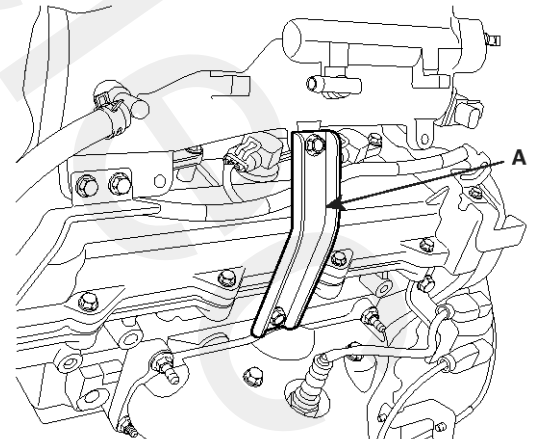

KCBF178A

8. Remove the surge tank(A).

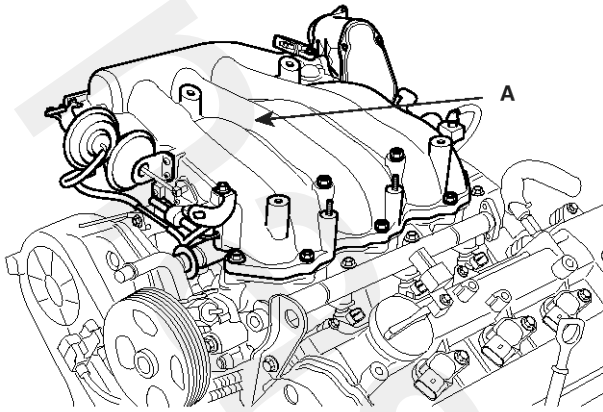

KCBF181A

9. Remove the delivery pipe assembly(A).

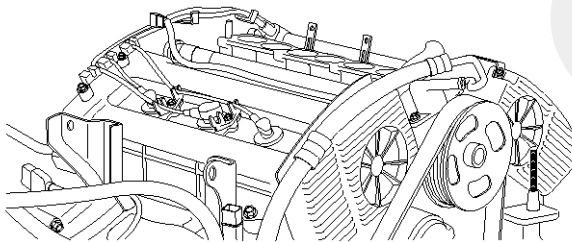
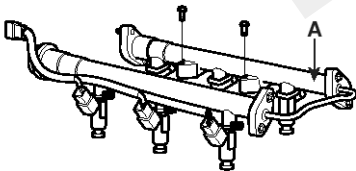

EDQF007A

10. Remove the intake manifold assembly(A).

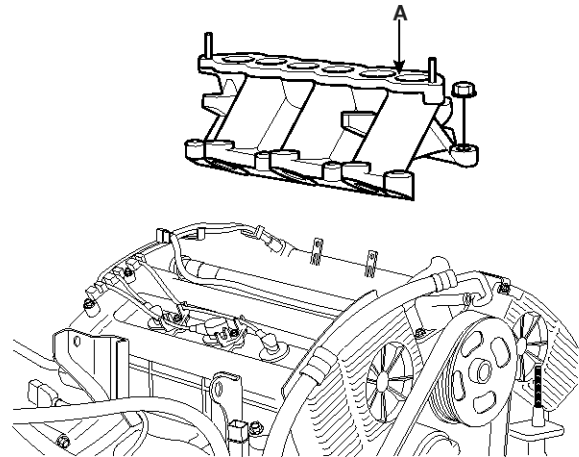

EDQF063A

## EXHAUST MANIFOLD ASSEMBLY

1. Remove the under cover.
2. Remove the front muffler(A).

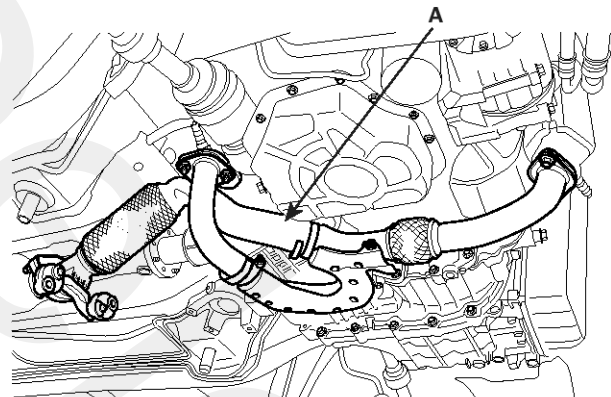

SCMEM6005L

3. Disconnect the oxygen sensor connectors(A).

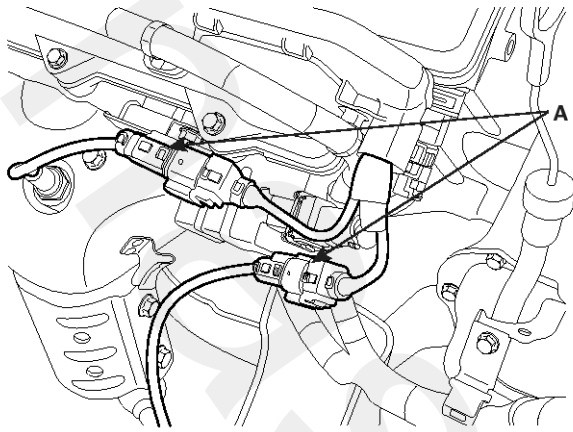

KCBF154B

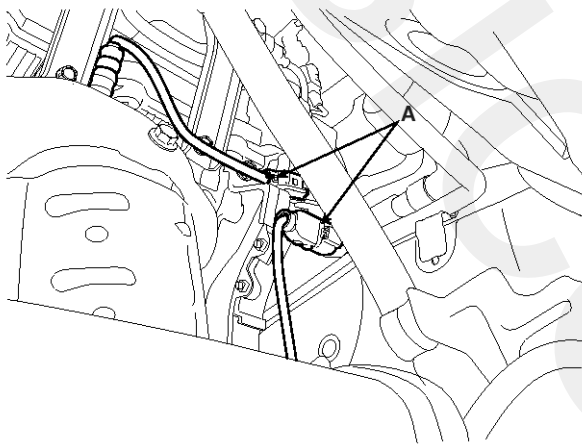

KCBF160A

4. Remove the oil level gauge.
5. Remove the heat protector(A).

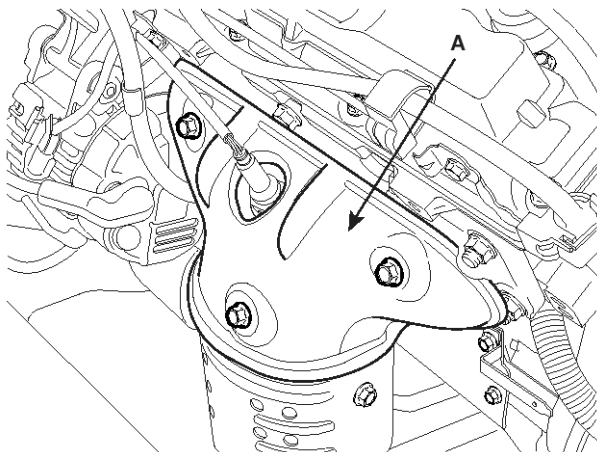

KDRF184A

6. Remove the exhaust manifold assembly.

## INSTALLATION

### INTAKE MANIFOLD ASSEMBLY

1. Install the intake manifold assembly with a new gasket to a cylinder head assembly. Tighten the bolts in two steps.

#### Tightening torque

Step 1(a~h): 3.9~5.9Nm(0.4~0.6kgf.m, 2.9~4.3lb-ft)

Step 2(1~8): 18.6~23.5Nm(1.9~2.4kgf.m, 13.7~17.4lb-ft)

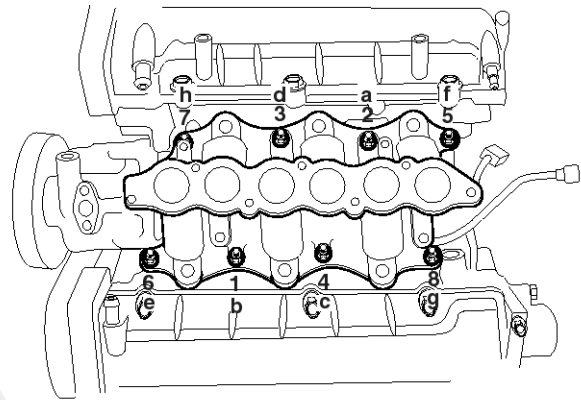

KCBF201A

#### ⚠ CAUTION

When installing the gasket on the cylinder head, check the identification marks(LH/RH) not to be installed wrong.

2. Install the delivery pipe.
3. Connect the LH injector connector.
4. Install the surge tank.

#### Tightening torque

18.6~23.5Nm(1.9~2.4kgf.m, 13.7~17.4lb-ft)

5. Install the surge tank mounting bracket.

#### Tightening torque

18.6~23.5Nm(1.9~2.4kgf.m, 13.7~17.4lb-ft)

6. Install the ETC(Electronic Throttle Control) system fixing bracket.
7. Connect the hoses and connectors.
8. Install the air cleaner assembly.
9. Install the engine cover.

## EXHAUST MANIFOLD ASSEMBLY

1. Install the exhaust manifold assembly with a new gasket.

---

### Tightening torque

29.4~34.3Nm(3.0~3.5kgf.m, 21.7~25.3lb-ft)

---

2. Install the heat protector.

---

### Tightening torque

16.7~21.6Nm(1.7~2.2kgf.m, 12.3~15.9lb-ft)

---

3. Install the front muffler assembly.

---

### Tightening torque

39.2~58.8Nm(4.0~6.0kgf.m, 28.9~43.4lb-ft)

---

4. Connect the oxygen sensor connector.
5. Install the under cover.