

OPTIMA

Features & Functions Guide



Delivery First

The priority that delivers more



GETTING TO KNOW YOUR **OPTIMA**

Congratulations on Your New Kia Purchase!

Your new Kia vehicle has been designed, engineered and manufactured to provide you with years of comfortable and dependable driving. Kia is committed to quality, innovation, safety and — above all — your satisfaction.

Using This Guide

The information contained in this guide is a brief overview that will help you become familiar with the operation and features of your new Kia vehicle. The flipbook format facilitates information access, while the detailed illustrations help to ensure the instructions are easy to follow.

This **Features & Functions Guide**, and the specific operational and safety information it provides, is not a substitute for your Owner's Manual. In the interest of your safety and that of your family, and to help you avoid risks that may result in death or serious injury, Kia reminds you to carefully read your Owner's Manual in order to fully familiarize yourself with the important information it contains.

While the information contained in this guide is accurate at the time of printing, Kia may change vehicle specifications without notice in advance or after the fact, and assumes no liability in connection with such changes.

www.kia.com

Consumer - Roadside Assistance
1-800-333-4KIA (4542)

See Back Pages for Vehicle Maintenance Schedule

Always check the Owner's Manual for complete operating information and safety warnings.

ESSENTIAL FEATURES

| | |
|---|----|
| Air Conditioning / Climate Control | 28 |
| Audio System - Standard Audio System* | 22 |
| Audio System - UVO eServices Setup* | 23 |
| Audio System - UVO eServices System* | 24 |
| Audio System - UVO eServices with Premium Navigation* | 25 |
| Aux/USB/iPod®* Port* & Power Outlets | 27 |
| Bluetooth® Wireless Technology | 18 |
| Cruise Control | 21 |
| Digital Clock | 27 |
| ECO Mode (Active ECO)* | 09 |
| Passenger Airbag Off Indicator | 40 |
| Tire Mobility Kit* | 39 |
| Tire Pressure Monitoring System (TPMS) | 05 |
| Windshield Wipers & Washers | 16 |

Driving while distracted can result in a loss of vehicle control that may lead to an accident, severe personal injury and death. The driver's primary responsibility is in the safe and legal operation of a vehicle, and use of any handheld devices, other equipment or vehicle systems which take the driver's eyes, attention and focus away from the safe operation of a vehicle or that are not permissible by law should never be used during operation of the vehicle.



| | |
|-----------------------------|----|
| VIDEOS & QR CODES | 02 |
|-----------------------------|----|

INSTRUMENT CLUSTER

| | |
|--|----|
| Instrument Cluster Overview | 03 |
| Indicators & Warning Lights | 04 |
| Tire Pressure Monitoring System (TPMS) | 05 |
| LCD Instrument Cluster Modes | 06 |
| Trip Modes / Trip Computer | 06 |
| Instant Fuel Consumption Mode* | 07 |
| Fuel Economy | 07 |
| User Settings | 08 |
| Service Mode | 08 |
| Drive Mode Integrated Control System* | 09 |
| ECO Mode (Active ECO)* | 09 |

DRIVER'S PANEL

| | |
|--|----|
| Blind Spot Detection System* | 10 |
| Instrument Panel Dimmer* | 11 |
| Electronic Stability Control (ESC) | 11 |
| Hill-Start Assist Control (HAC) | 11 |
| Lane Departure Warning System (LDWS)* | 12 |
| Autonomous (Assist) Emergency Braking (AEB) / Forward Collision Warning System (FCWS)* | 12 |
| Engine Start/Stop Button* | 13 |
| Power Windows, Window Lock & Central Door Lock* | 14 |
| Automatic Door Lock/Unlock | 14 |
| Power/Heated Outside Mirrors* | 14 |
| Power Folding Mirrors* | 14 |

STEERING WHEEL CONTROLS

| | |
|---|----|
| Turn Signals | 15 |
| Headlights & High Beams | 15 |
| Windshield Wipers & Washers | 16 |
| Heated Steering Wheel* | 16 |
| Tilt/Telescoping Steering Wheel* | 17 |
| Paddle Shifters* | 17 |
| Bluetooth® Wireless Technology | 18 |
| Advanced Smart Cruise Control (ASCC)* | 20 |
| Audio Controls* | 21 |
| Cruise Control | 21 |

AUDIO SYSTEMS

| | |
|--|----|
| Standard Audio System* | 22 |
| UVO eServices Setup* | 23 |
| UVO eServices System* | 24 |
| UVO eServices with Premium Navigation* | 25 |

CENTER PANEL

| | |
|--|----|
| Surround View Monitoring (SVM) System* | 26 |
| Digital Clock | 27 |
| Aux/USB/iPod® Port & Power Outlets | 27 |
| USB Charger* | 27 |
| Wireless Smartphone Charging System* | 27 |
| Automatic Climate Control* | 28 |
| Manual Climate Control* | 29 |
| Electric Parking Brake (EPB)* | 30 |
| Auto Hold* | 30 |
| Automatic Gear Shift with Sportmatic® Shifting | 31 |

SEATING

| | |
|--|----|
| Front Seat Headrest Adjustment | 32 |
| Driver Position Memory System* | 32 |
| Power Adjustable Driver's Seat* | 32 |
| 6-Way Manual Adjustable Driver's Seat* | 33 |
| Seat Warmers / Ventilated Seats* | 33 |

OTHER KEY FEATURES

| | |
|---|----|
| Smart Key* | 34 |
| Remote Keyless Entry (Folding Key)* | 35 |
| Double-Turn Lock/Unlock All | 35 |
| Fuel Cap / Malfunction Indicator (Check Engine Light) | 35 |
| Sunvisor | 35 |
| Map/Room Lamps | 36 |
| Panoramic Sunroof Operation* | 36 |
| Fuel Door and Trunk Release | 37 |
| Trunk Release Button (Exterior) | 37 |
| Smart Trunk* | 37 |
| Hood Release Lever and Latch | 38 |
| Child-Protector Rear Door Lock | 38 |
| Back-Up Warning System (Rear Parking Assist System)* | 38 |
| Rear-Camera Display* | 39 |
| Tire Mobility Kit | 39 |

SAFETY FEATURES

| | |
|--|----|
| Occupant Detection System (ODS) / Passenger Airbag Off Indicator | 40 |
| Seat Belts | 40 |
| Seat Belt Retractor Locks | 40 |

NORMAL MAINTENANCE SCHEDULE 41

LEGAL DISCLAIMERS . . . (See Back Inside Cover Page)

Kia provides a number of video resources at your disposal to assist you with becoming familiar with the features and functions found in your Kia vehicle. You can access these resources by snapping the QR Codes with your smartphone/tablet (mobile devices) or by visiting the following website: www.KuTechVideos.com/jf13/2017. Continue reading for a more in-depth look at QR Codes and for instructions on how to use them.

What are QR Codes?

A QR Code is a square, 2-dimensional barcode that can be read by mobile devices loaded with an appropriate barcode or QR Code Reader App. The app reads the barcode image and then launches/uploads the specific information the code contains, such as URLs, text, photos, videos and so much more.

How to Use QR Codes

If you have a mobile device with a QR Code Reader App, you can snap the code with your phone and you'll be provided a video with additional information pertaining to the topic. For example, in the Fuel Cap section, if you would like additional information, just snap the code with your mobile device to view the selected Kia Features & Functions Video.

How to Snap a QR Code

1. With your mobile device, download a QR Code Reader App. With many devices, you can do this through an app store or marketplace
2. Open the QR Code Reader App on your mobile device
3. The app will utilize your device's camera. Center the code in the camera viewing area:
 - With some apps, as soon as the app recognizes the code, it will launch the corresponding video
 - With other apps, you will have to snap or take a picture of the code. The app will then launch the corresponding video
 - For operation specifics, refer to the instructions that come with the QR Code Reader App

QR CODE

One Click Fuel Cap Video

To view a video on your mobile device, snap this QR Code or visit the listed website.



www.KuTechVideos.com/jf13/2017

REMINDER: When accessing videos on your mobile device, standard cellular data rates may apply.

QUICK TIPS

1. If you're having trouble scanning codes, check the following:
 - The code should be centered and focused in your mobile device's camera screen
 - Consider moving your device closer to or farther away from the code
 - The code should be well lit, without significant shadow
 - Avoid scanning from a significant angle
 - Confirm that the device's app supports 2D QR Code scanning
 - Try another QR Code Reader App; not all apps are created equal
2. After scanning, if a "connecting" message appears and then nothing happens or there's a "connection error" message, this typically indicates that your device is having trouble connecting to the Internet

Instrument Cluster Overview

- A** Tachometer
- B** Indicator & Warning Lights
- C** Speedometer
- D** LCD Screen
- E** Turn Signal Indicators
- F** Engine Temperature Gauge*
- G** Fuel Gauge
- H** Gear Shift Position Indicator*

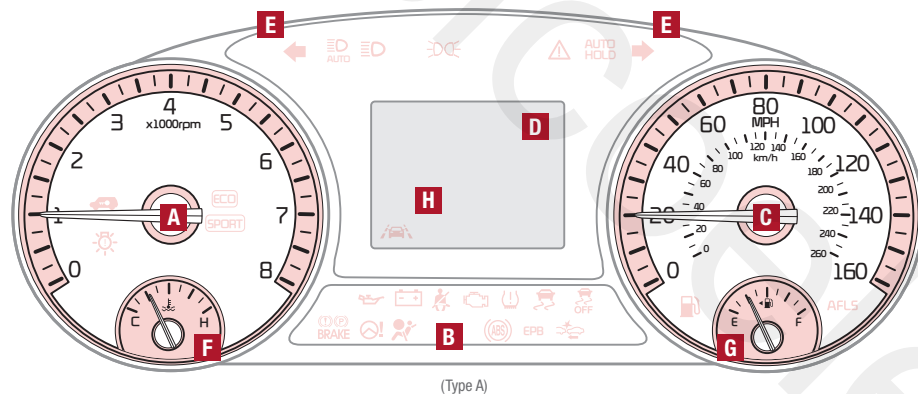





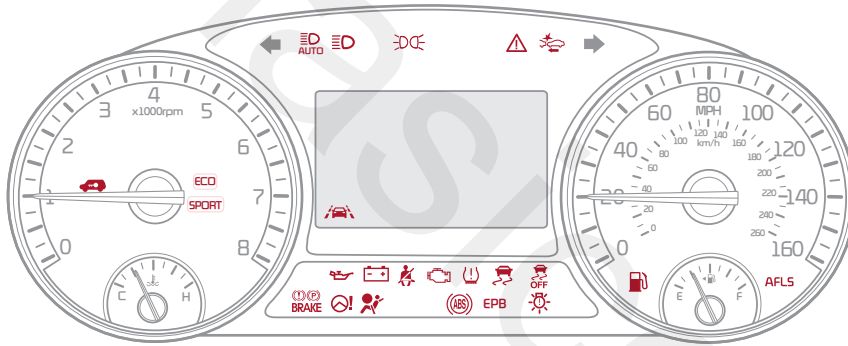

Your vehicle's instrument cluster & indicator light locations may differ from those in the illustrations. For more information on the instrument cluster, the LCD Warning Messages and the function of all indicator and warning lights, please refer to the Owner's Manual.

Indicators & Warning Lights







(Type B)

Your vehicle's instrument cluster & indicator light locations may differ from those in the illustrations. For more information on the instrument cluster, the LCD Warning Messages and the function of all indicator and warning lights, please refer to the Owner's Manual.

- | | | |
|--|---|---|
|  Immobilizer Indicator Light* |  Charging System Warning Light |  Master Warning Light* |
|  ECO Indicator Light* |  Airbag Warning Light |  Autonomous Emergency Braking (AEB) Warning Light* |
|  SPORT Mode Indicator Light* |  Seat Belt Warning Light |  Lane Departure System (LDWS) Indicator Light* |
|  High Beam Assist Indicator* |  Malfunction Indicator Lamp (MIL)* |  Low Fuel Level Warning Light |
|  High Beam Indicator |  Low Tire Pressure Indicator / TPMS Malfunction Indicator |  Electronic Brake force Distribution (EBD) System Warning Light |
|  Low Beam Indicator Light* |  Anti-lock Braking System (ABS) Warning Light | CRUISE Cruise Indicator Light* |
|  Light ON Indicator Light |  Electronic Stability Control (ESC) Indicator Light* | SET Cruise SET Indicator Light* |
|  Parking Brake & Brake Fluid Warning Light |  Electronic Stability Control OFF (ESC) OFF Indicator Light* | AUTO HOLD AUTO HOLD Indicator Light* |
|  Engine Oil Pressure Warning Light | EPB Electronic Parking Brake (EPB) Warning Light* | AFLS Adaptive Front Lighting System* |
|  Electric Power Steering (EPS) Warning Light | | |

Tire Pressure Monitoring System (TPMS)

 The TPMS indicator  functions as both Low Tire Pressure Light and TPMS Malfunction Indicator. The indicator  will illuminate if one or more tires is significantly underinflated, the vehicle has a spare tire installed without TPMS or the outside temperature becomes significantly lower.

The Low Tire Pressure Position Indicator  is displayed on the LCD screen in the Instrument Cluster when the tire(s) are underinflated. Inflate tire(s), using an accurate digital tire pressure gauge, to specifications to turn off Low Tire Pressure Position Indicator  - See front driver's door jamb for PSI specification.

When there is a problem with the TPMS, the TPMS Malfunction Indicator  will blink for approximately one minute then illuminate—see dealer for service.

QUICK TIPS

- Even with TPMS, tire pressure should be checked manually at least once a month. Only adjust tire pressure on “cold tires”
- For proper maintenance and optimal fuel economy, maintain recommended tire inflation pressures and stay within the load limits and weight distribution recommended for your vehicle
- In winter or cold weather, the TPMS light may illuminate if the tire pressure was adjusted to the recommended tire inflation pressure during warm weather

REMINDERS:

- Check the recommended tire pressure label located on the left side of driver's door jam, visible when the door is open.
- Consult your dealer for service if Low Tire Pressure Light remains illuminated after inflating your tire(s).

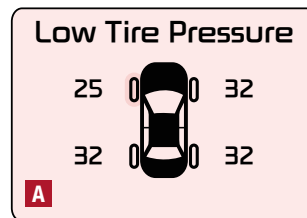

(Type B cluster screen shown)

QR CODE

Tire Pressure Monitoring System Video

To view a video on your mobile device, snap this QR Code or visit the listed website.

Refer to page 2 for more information.



www.KuTechVideos.com/jf13/2017

LCD Instrument Cluster Modes*

Press Mode button **A** to scroll through different LCD Instrument Cluster Modes.

Type B cluster:



Trip Computer Mode: Displays driving information for tripmeter, fuel economy, etc.



Turn-by-Turn Mode*: Displays the state of the navigation



Advanced Smart Cruise Control (ASCC) / Lane Departure Warning System (LDWS)*: Displays the state of the ASCC and LDWS



A/V Mode*: Displays the state of the A/V System



Service Modes: Informs on upcoming service intervals / Warning messages related to TPMS and others / When any door is not securely closed, this indicator will illuminate



User Settings Mode: Change settings of the doors, lamps and other features

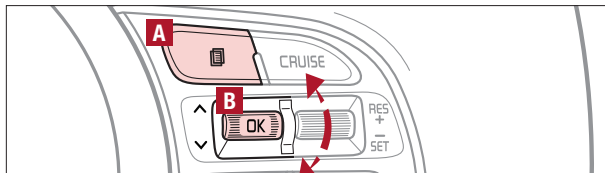

(Type A; Buttons located on Steering Wheel)

Your vehicle's steering wheel buttons may differ from those in the illustrations.

Trip Modes / Trip Computer

The Trip Computer is a system to relay pertinent driving information. It appears on the display when the ignition switch or the Engine Start/Stop button* is in the ON position.

To cycle through the Trip Modes, press the Mode button **A**.

When in the Trip Computer mode , press the Select/Reset button **B** to cycle through the screens. When displaying TRIP A or TRIP B screens, press and hold the Select/Reset button **B** to reset the Tripmeter to zero (Type A Steering Wheel).

REMINDERS:

- Appearance of Tripmeter display may differ as equipped
- All stored driving information (except Odometer and Range) is reset if the battery is disconnected

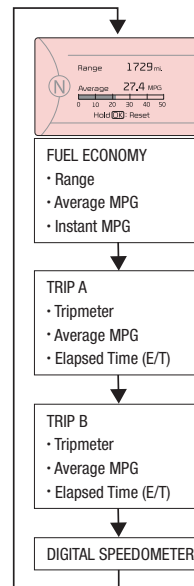

(Type B Cluster)

Instant Fuel Consumption Mode*

Press button **A** to cycle to the Trip Computer screen, then toggle up or down with button **B** to cycle to the Fuel Economy screen. The bar at the bottom of the screen displays the calculated Fuel Consumption during the past few seconds when the vehicle speed is more than approximately 6 MPH.

1. Keep your vehicle in good condition with regular maintenance
2. Travel lightly, without carrying unnecessary weight in your vehicle
3. Don't let the engine idle longer than necessary

REMINDERS:

- Not to be used in calculating or as a reference for AVERAGE fuel economy
- If the vehicle speed exceeds 1 MPH (1.6 km/h) after being refueled with more than 1.6 gallons (6 liters), the average fuel economy will be cleared to zero (---)

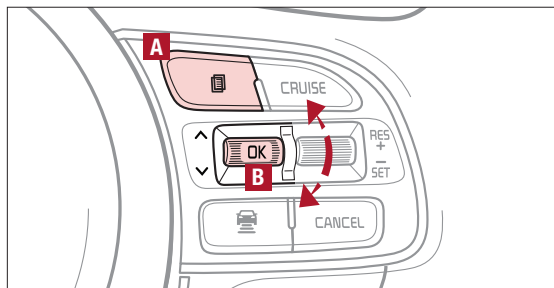

(Type A - Buttons located on Steering Wheel)

Your vehicle's steering wheel buttons may differ from those in the illustrations.

Fuel Economy

There are several factors that contribute to your vehicle's fuel economy, including maintenance of your vehicle, driving style, environmental conditions, vehicle weight and vehicle aerodynamics. Below are tips on how to help improve fuel economy:

- Keep your vehicle in good condition with regular maintenance
- Don't let the engine idle longer than necessary
- Drive at a moderate speed, accelerating smoothly and at a moderate rate
- Keep tires inflated to the recommended pressure
- Travel lightly, without carrying unnecessary weight in your vehicle
- Avoid placing large or heavy items on roof racks
- Avoid hilly, winding or poorly maintained roads

REMINDER: Driving range can vary depending on your vehicle's fuel tank size, e.g., 12-gal. vs. 24-gal., even though the MPG may be the same

For more information on Fuel Economy, you can snap the QR Code above to view a video or refer to the brochure "GETTING MORE OUT OF EVERY GALLON, FUEL-SAVING TIPS TO DRIVE BY" available at your local dealership.

QR CODE

Fuel Economy Video

To view a video on your mobile device, snap this QR Code or visit the listed website.

Refer to page 2 for more information.



www.KuTechVideos.com/jf13/2017

User Settings

To enter the User Settings mode in the LCD Instrument Cluster Modes, press the Mode button **A** when the vehicle is at a standstill and with the ignition switch or the ENGINE START/ STOP button* in the ON position and select User Settings .

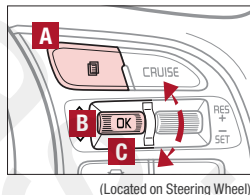

You can navigate the selections on the display by pressing the Move/Scroll button **B** up and down, and then selecting the item by pressing the Select/Reset button **C**.

Driving Assist*:

- Smart Cruise Control Response*
- Rear Cross Traffic Alert (RCTA)*
- FCW (Forward Collision Warning)*
- AEB (Autonomous Emergency Braking)*

Door/Trunk:

- Automatic Lock & Unlock
- Smart Trunk*
- Two-Press Unlock
- Horn Feedback

Lights:

- One-Touch Turn Signal*
- Headlamp Delay
- Welcome Light*

Sound:

- Park Assist System Volume*
- Blind Spot Detection Sound*
- Welcome Sound*

Convenience:

- Seat Easy Access*
- Steering Position
- Wireless Charging System*
- Wiper/Light Display*

Service Interval:

- Service Interval On/Off
- Set mileage/months

Other Features:

- Fuel Economy Auto Reset
- Fuel Economy Unit
- Temperature Unit
- Tire Pressure Unit*

Service Mode

To enter Service mode, press the Mode button **A**, scroll using **B** (Move/Scroll) to Service Mode  and press Select/Reset button **C**. System will display number of miles remaining until next service is due, as well as type of service.

When service is required, the following will be displayed: **Service Required**.

To reset the Service mode system, press and hold the Select/Reset button **C** for more than 1 second.

To turn Service In OFF, go to User Settings.

Service Interval Setting

To set the service interval when in User Settings mode:

- Press the Move button **B** and scroll to Service Interval. Press the Select/Reset button **C** to enter
- Press the Move button **B** and toggle to ON, then press the Select/Reset button **C**. Then press the Move button **B** to scroll and select the desired miles or months for your next service
- Press the Select/Reset button **C** to enter

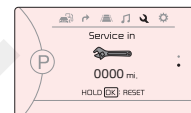

(Type B cluster)

QR CODES

To view a video on your mobile device, snap these QR Codes or visit the listed website.

Refer to page 2 for more information.

LCD Display: Maintenance Video



www.KuTechVideos.com/f/13/2017

LCD Display Video



www.KuTechVideos.com/f/13/2017

Drive Mode Integrated Control System*

The Drive Mode may be selected depending on driver's preferences and road conditions.

To cycle through the different Drive Modes **A**, press the DRIVE MODE button **B**. The Instrument Cluster will display SPORT or ECO when selected. When in Normal mode, it will not display in the Instrument Cluster.

REMINDERS:

- The system is turned ON and in Normal mode when ignition is in the ON position
- When ECO mode is selected, the indicator will display and system remains on, even when ignition is cycled

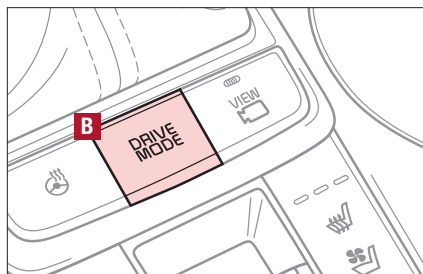

(Type C - Located below gear shift)

ECO Mode (Active ECO)*

The ECO Mode system helps improve fuel economy by controlling several vehicle components. When activated, it optimizes drivetrain operations such as engine power and transmission to help improve fuel economy.

To turn ON, press DRIVE MODE* **B** or the ECO Mode button. The button light will turn on, and the green ECO indicator light **C** in the instrument cluster will illuminate (indicating that you are getting optimal fuel efficiency). The ECO Mode system will remain on even when the ignition is cycled.

To turn the ECO Mode system OFF, press DRIVE MODE* **B** or the ECO Mode button again.



(Located in Instrument Cluster)

QUICK TIPS

To help improve your fuel economy:

- Drive at a moderate speed, accelerating smoothly and at a moderate rate
- Keep tires inflated to the recommended pressure
- Be sure the wheels are properly aligned

For more information on ECO Mode, refer to your Owner's Manual or contact your local dealership.

QR CODE

Active ECO System Video

To view a video on your mobile device, snap this QR Code or visit the listed website.

Refer to page 2 for more information.



www.KuTechVideos.com/jf13/2017

Blind Spot Detection (BSD) System*

The BSD system uses radar sensors to help alert the driver before changing lanes. The light on the BSD button **A** will illuminate when turned ON. The outside rearview mirror warning lights will also illuminate for 3 seconds.

The system will become active when the vehicle is traveling more than 18 mph and will alert the driver if another vehicle is detected by the radar sensor.

Blind Spot Detection / Lane Change Assist

1st-stage alert: When another vehicle is detected within the BSD System boundary **B**, a yellow indicator will illuminate on the outside rearview mirrors.

2nd-stage alert: When 1st-stage alert is on and the driver activates a turn signal, a flashing yellow indicator will illuminate on the outside rearview mirrors and the system will sound an alert.

RCTA (Rear Cross Traffic Alert)

If the RCTA system sensors detect approaching vehicles from the left or right side **C**, the system will sound an audible alert, the warning indicators on the outside rearview mirror will illuminate and a message will appear on the LCD screen, with these conditions:

- When the vehicle is in Reverse
- When the vehicle moves in reverse from a parking position
- When the vehicle is moving less than 6 mph

REMINDERS:

- If the BSD is turned ON and the ignition is cycled, the BSD system returns to ON
- The RCTA feature can be turned OFF/ON in User Settings
- The RCTA system will not show a warning if the vehicle speed is only 6 mph above the surrounding vehicles

For more information on the Blind Spot Detection System, please refer to the Owner's Manual.

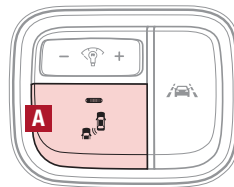

(Located left of Steering Wheel)

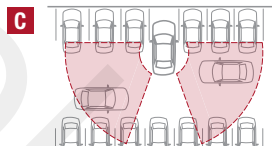
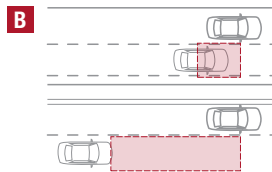

REMINDER: The above images are for illustration purposes only and may not reflect actual operation.

QR CODE

Blind Spot Detection with RCTA Video

To view a video on your mobile device, snap this QR Code or visit the listed website.

Refer to page 2 for more information.



www.KuTechVideos.com/ft13/2017

Instrument Panel Dimmer

Press left/right side of switch **A** to adjust the display brightness of the instrument panel illumination.

REMINDERS:

- Dimmer does not change brightness when lights are turned off.
- The Instrument Panel Dimmer does not adjust brightness on the navigation system screen, use UVO eServices with Premium Navigation system setup to adjust brightness on the navigation system.

Electronic Stability Control (ESC)

The ESC system is designed to help stabilize the vehicle during cornering maneuvers. It is a good idea to keep the ESC turned ON for daily driving whenever possible.

Press ESC OFF button **B** to disable Traction Control in ESC (ESC OFF indicator will illuminate).

To turn both Traction Control and Stability Control off, press and hold ESC OFF button **B** (ESC OFF indicator will illuminate, and an alert sounds).

REMINDERS:

- ESC is active by default at vehicle start-up. When ignition is cycled, ESC will turn ON again
- The ESC Indicator Light  in the instrument cluster will illuminate whenever the ESC is in operation

For more information on Electronic Stability Control (ESC) and its specific features and operations, please refer to your Owner's Manual.

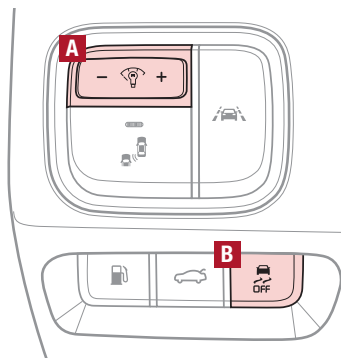

(Located left of Steering Wheel)

Hill-Start Assist Control (HAC)

HAC helps prevent the vehicle from rolling backward when accelerating from a stop while on a steep incline.

The HAC automatically activates whether the ESC is OFF or ON but does NOT activate when the ESC has malfunctioned.

REMINDERS:

- The HAC does not operate when the gear shift is in the P (Park) or the N (Neutral) position.
- In the event of HAC system malfunction, see Authorized Kia Dealer for service.

QUICK TIPS

- When HAC is active (e.g., accelerating from a stop on an incline), you may notice that the brakes will momentarily remain engaged after you depress the accelerator
- HAC provides a 2-second delay before the vehicle may start rolling backward

Lane Departure Warning System (LDWS)*

With the ENGINE START/STOP button in the ON position, press the LDWS button **A** to turn system ON. The instrument cluster indicator  will illuminate green. LDWS will stay on when the ignition is cycled.

If the LDWS detects that you are veering outside of your lane, the system may issue a warning on the LCD screen and an alert may sound, under these conditions:

- The vehicle exceeds approximately 37 mph
- The LDWS system recognizes the lane the vehicle is traveling in

REMINDERS:

- LDWS will not issue a warning if the turn signal is activated
- If the LDWS button is ON and ignition is cycled, the system will turn ON again. If the LDWS button is OFF, the system remains OFF

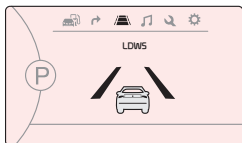

When the LDWS sensor detects the lane traveling in

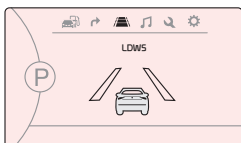

When the LDWS sensor does not detect the lane traveling in



When the LDWS sensor detects the vehicle veering outside of the lane traveling in, a yellow indicator will illuminate

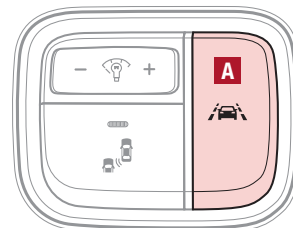
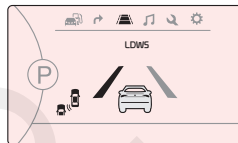

(Located left of Steering Wheel)

QR CODE

Lane Departure Warning System Video

To view a video on your mobile device, snap this QR Code or visit the listed website.

Refer to page 2 for more information.



www.KuTechVideos.com/f/113/2017

Autonomous (Assist) Emergency Braking (AEB) / Forward Collision Warning System (FCWS)*

The AEB helps to alert the driver when rapidly approaching a vehicle that is slowing down, braking or stopped. A warning message will appear on the LCD screen and a chime will sound. The AEB will become active when the vehicle is traveling more than 20 mph.

To turn the AEB off, go to User Settings in the LCD Instrument Cluster modes.

REMINDERS:

- The AEB will be activated by default when vehicle power is cycled on, even when previous setting to off
- The AEB will not operate when the vehicle is traveling more than approximately 50 mph

The Autonomous (Assist) Emergency Braking (AEB) / Forward Collision Warning System (FCWS) is not a substitute for safe and proper driving. Always drive safely and use caution. FCWS may not always alert the driver when the vehicle is approaching another vehicle.



Engine Start/Stop Button*

To start the engine:

1. Depress the brake pedal
2. Press the ENGINE START/STOP button while gear shift is in P (Park)

To turn the engine OFF, press the ENGINE START/STOP button.

To use the ENGINE START/STOP button, you must have the Smart Key fob on your person.

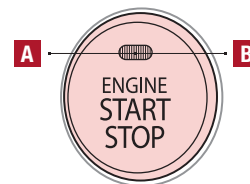

REMINDERS:

- In an emergency situation while the vehicle is in motion, you are able to turn the engine off and to the ACC position by pressing the ENGINE START/STOP button for more than 2 seconds or 3 times successively within 3 seconds
- If the Smart Key battery is weak or not working properly, hold the Smart Key fob up to the ENGINE START/STOP button (Lock button side closest) and press to start engine

QUICK TIPS

To use electrical accessories:

ACC position

- When in the OFF position and without depressing the brake pedal, press the ENGINE START/STOP button once (amber light **A**)

ON position

- When already in the ACC position (amber light **A**) and without depressing the brake pedal, press the ENGINE START/STOP button again (red light **B**)
- When in the OFF position and without depressing the brake pedal, press the ENGINE START/STOP button twice (red light **B**)

Keeping the vehicle in ACC or ON position without turning engine on may discharge the vehicle's battery

QR CODE

Engine Start/Stop Button & Smart Key Video

To view a video on your mobile device, snap this QR Code or visit the listed website.

Refer to page 2 for more information.



www.KuTechVideos.com/jf13/2017

Power Windows, Window Lock & Central Door Lock

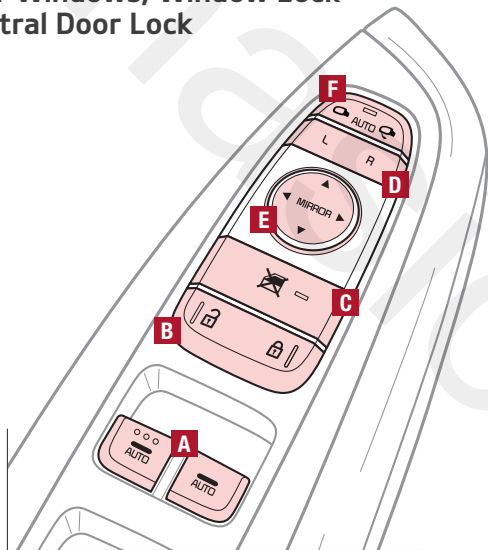

- A** Pull/Press to operate Driver's and Front Passenger's Windows Auto-Up/Down*

QUICK TIP

Press button again to stop Auto Up/Down function

- B** Press to Unlock/Lock All Doors
- C** Press to disable Rear Passenger Windows

REMINDER: When pressed **C**, window controls for the Rear Passenger Windows are disabled.

Automatic Door Lock/Unlock

Auto Door Lock/Unlock will engage when the gear shift is moved in to or out of the P (Park) position. Refer to the User Settings in the LCD Instrument Cluster modes on how to turn Auto Door Lock/Unlock ON/OFF.

Power/Heated Outside Mirrors*

Mirror heaters controlled with Rear Defroster.

Power Folding Outside Mirrors*

Toggle **D** left or right to select mirror. Then press arrows **E** to adjust mirror position.

To both fold and unfold the outside rearview mirror, press the folding mirror button **F** as pictured.

REMINDER: To lock position of mirrors, toggle switch to the neutral (center) position.

QUICK TIP

To automatically fold mirrors when exiting vehicle, press the LOCK button once on the key fob or Smart Key*.

Turn Signals*

To operate Turn Signals - Move lever Up/Down for Right/Left Turn Signal

One-Touch Lane Change Signal

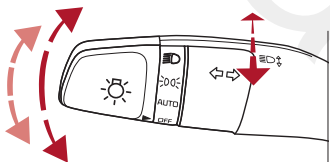

One-Touch Lane Change Signal is activated by moving the Turn Signal Lever slightly for less than 1 second and then releasing. The lane change signal will blink 3 times.

To change how many times the Lane Change Signal blinks (3/5/7), go to User Settings Mode in the LCD Instrument Cluster modes.

Headlights & High Beams

To operate:

- Rotate lever to change the Headlight function
- Push lever to turn High Beams ON
- Pull lever to flash Headlights/High Beams

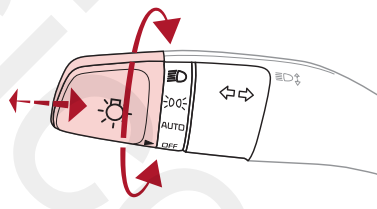

- ☾ Headlight position
- ☾ Parking light position
- AUTO* Auto Light Position* / AFLS (Adaptive Front Lighting System)* / High Beam Assist*
- OFF OFF position

AUTO Light position — When the light switch is in the AUTO Light position, the tail lights and headlights will turn ON/OFF automatically depending on the amount of light outside the vehicle.

Adaptive Front Lighting System (AFLS)* — The Adaptive Front Lighting System helps improve visibility during nighttime driving by aiming the low beam headlights in the direction the vehicle is moving. AFLS controls the aiming direction based on steering angle and speed. When the headlight switch is in the AUTO Light position, the AFLS will activate.

REMINDER: When the AFLS indicator illuminates on the instrument cluster, the AFLS is not working properly. See authorized Kia dealer for service.

High Beam Assist* — The High Beam Assist will automatically adjust the brightness depending on brightness of oncoming vehicles and road conditions. When switch is in the AUTO position and the vehicle's ignition or the Engine Start/ Stop button* is on, the High Beam Assist will operate. To turn the system off, change the switch setting.

QR CODE

Dynamic Bending Light (AFLS) Video

To view a video on your mobile device, snap this QR Code or visit the listed website.

Refer to page 2 for more information.



www.KuTechVideos.com/jf13/2017

Windshield Wipers & Washers

To operate:

- Move lever Up/Down to change Wiper modes
- Press switch Up/Down to adjust Intermittent Wipe Speed
- Pull lever to spray and wipe

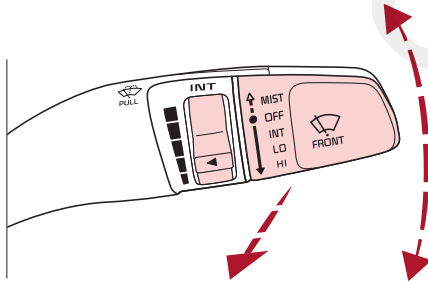

MIST: Single wipe
OFF: Wiper off
INT: Intermittent wipe
LO: Slow wiper
HI: Fast wiper

QUICK TIPS

- Pressing lever up increases Intermittent wipe frequency and wipe speed. Pressing lever down decreases frequency of wipes
- Set the wiper to OFF position when the wiper is not in use

Heated Steering Wheel Button*

Press button **A** to turn ON/OFF steering wheel heater, while the ignition or ENGINE START/STOP button is in the ON position.

Steering wheel heater will turn off automatically in 30 minutes, or when button is pressed again to deactivate.

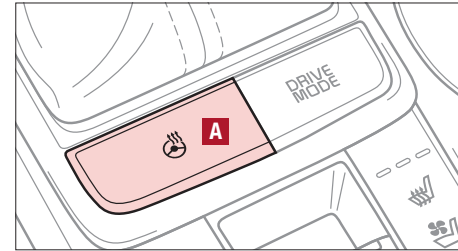

(Located below gear shift)

QUICK TIP

If ignition is turned OFF, then ON again, within 30 minutes of steering wheel heater being turned on, system will automatically be set ON again.

Tilt/Telescoping Steering Wheel*

To adjust the Steering Wheel, push the lock-release lever **A** down and adjust to the desired angle **B** and distance **C**.

When finished, pull the lock-release lever **A** up to lock Steering Wheel in place.

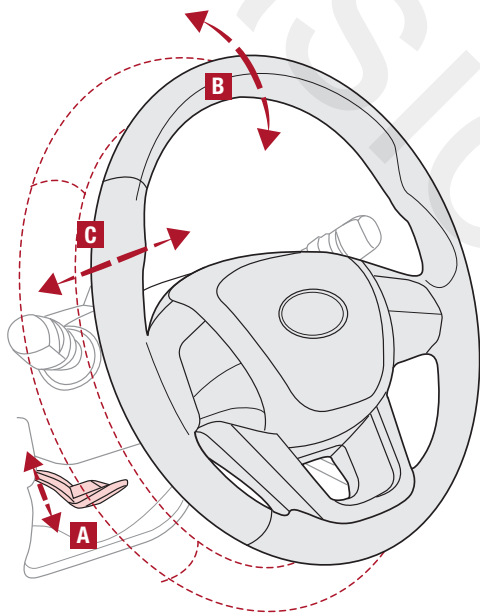

QUICK TIP

It may be helpful to pull/push bottom of Steering Wheel towards/away from you to adjust desired distance prior to adjusting the angle.

ALWAYS CHECK THE OWNER'S MANUAL FOR COMPLETE OPERATING INFORMATION AND SAFETY WARNINGS.

Paddle Shifters*

Paddle Shifters are operable when the shift lever is in the D position or in Sport mode.

Paddle Shifting: Pull the [+] or [-] paddle shifter once to shift up or down one gear.

REMINDERS:

- The Paddle Shifters can be operated when the vehicle speed is more than 6 mph
- When in Sport mode, pulling the left and right paddle shifters at the same time will NOT shift gears

QUICK TIPS

- Press brake pedal and depress release button to move gearshift from N to P, N to R or from P to any gear
- Sport mode downshifts are made automatically when the vehicle slows down. When the vehicle stops, 1st gear is automatically selected

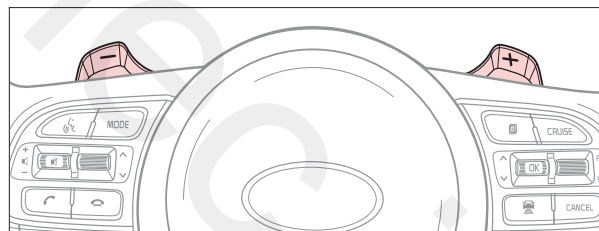

QR CODE

Paddle Shifters Video

To view a video on your mobile device, snap this QR Code or visit the listed website.

Refer to page 2 for more information.



www.KuTechVideos.com/jf13/2017

*IF EQUIPPED

Bluetooth® Wireless Technology

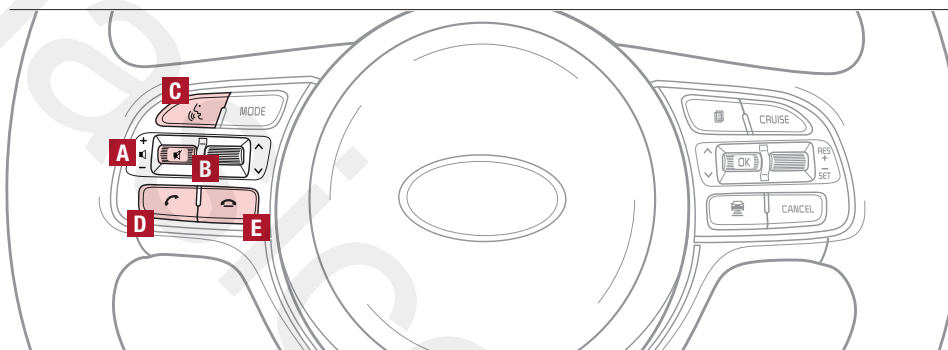

(Type C shown)

- A Volume button:** Press up/down to raise/lower speaker volume
- B Mute button:** Press to mute the microphone during a call
- C Talk button:** Press to activate voice recognition/bring up menus/place calls with minimal voice command prompts from the system

QUICK TIP

When using the voice command feature, wait for the system BEEP before speaking the command.

- D Receive/Place Call button:** Press to receive/place/transfer calls. Press to place a call using voice command prompts from the system, or to answer an incoming call
- E End Call button:** Press to end a call or cancel a function

QUICK TIPS

- Phonebook transfer upload time varies by phone model and with number of phonebook entries
- Because of differences in phone quality, service providers and **Bluetooth®** Wireless Technology chip programming, functionality may differ from one phone to another
- Changing language setting may delete paired phones

Your vehicle's steering wheel buttons may differ from those in the illustrations. See your Owner's Manual for more details

Driving while distracted is dangerous and should be avoided. Drivers should remain attentive to driving and always exercise caution when using the steering-wheel-mounted controls while driving.

For more information, if equipped, refer to the Car Multimedia System User's Manual or the UVO System User's Manual. For Bluetooth® Wireless Technology FAQs, go to www.kia.com, Owners section, or call Consumer Information for Bluetooth® Technology at (800) 333-4KIA. Refer to your Owner's Manual for more specific Bluetooth® Wireless Technology phone pairing and operation instructions.

Bluetooth® Wireless Technology

Pairing a Phone

For instructions on how to pair a phone, refer to the audio system's user's guide or your vehicle's Quick Start Guide.

QUICK TIP

During the pairing process, be sure to accept the connection requests on the phone for phonebook download and to allow acceptance of all future **Bluetooth®** connection requests.

How to Place a Call

When using the voice command feature, wait for the system BEEP before speaking the command.

There are two options for placing a call:

Standard Audio System

- Option 1: Press the Receive/Place Call button **D** (system will prompt you through call process)
- Option 2: Press the Talk button **C** (system will BEEP to indicate it is ready for call placement). Then say the command "Call {name}" or "Dial {number}"

UVO eServices with Premium Navigation System

- Option 1: Press the Receive/Place Call button **D** (displays the phone screen with number keypad)
- Option 2: Press the Talk button **C**. Then say the command "Call Name" or "Dial Number", followed by phonebook name or number

Voice Recognition and Phone Contact Tips

The Kia Voice Recognition System may have difficulty understanding some accents or uncommon names. When using Voice Recognition to place a call, speak in a moderate tone, with clear pronunciation.

Help your **Bluetooth®** Wireless Technology Voice Recognition performance by making a few simple changes to your phone contacts:

- Use full names vs. short or single-syllable names ("John Smith" vs. "Dad"; "Smith Residence" vs. "Home")
- Avoid using special characters or hyphens (@, &, #, /, -, *, +, etc.)
- Avoid using acronyms ("In Case Emergency" vs. "ICE")
- Spell words completely, no abbreviations ("Doctor Goodman" vs. "Dr. Goodman")

QR CODE

Voice Recognition Tips Video

To view a video on your mobile device, snap this QR Code or visit the listed website.

Refer to page 2 for more information.



www.KuTechVideos.com/jf13/2017

Advanced Smart Cruise Control (ASCC)*

The Advanced Smart Cruise Control (ASCC)* system allows you to set the vehicle to maintain a speed so long as it is not limited by traffic. When traffic is encountered, the vehicle will be slowed to maintain a set distance behind traffic without depressing the accelerator or brake pedal.

To set/adjust the ASCC speed:

- Push the CRUISE button **A** to turn system ON. The CRUISE indicator will illuminate on the instrument cluster
- Accelerate/decelerate to the desired speed
- Move the ASCC lever **B** to set or adjust speed

To set the vehicle-to-vehicle distance, press the ASCC button **C** on the steering wheel. The images on the LCD screen **D** and the Instrument Cluster **E** will change when scrolling through the settings. Each time the button is pressed, the vehicle-to-vehicle distance changes.

To turn system OFF, press the CRUISE button **A**. The CRUISE indicator on the instrument cluster will turn OFF and the LCD screen ASCC image will show canceled **F**.

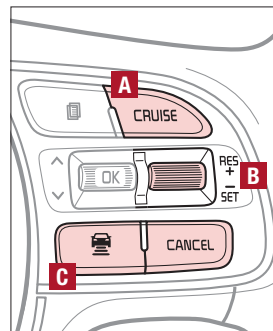

QR CODE

Advanced Smart Cruise Control Video

To view a video on your mobile device, snap this QR Code or visit the listed website.

Refer to page 2 for more information.



www.KuTechVideos.com/jf113/2017

QUICK TIPS

To change the Cruise Control mode from ASCC to standard Cruise Control, press and hold button **A**. Repeat to switch modes again (The ASCC system must not be activated to change modes).

For the ASCC System to operate:

- When no vehicle is in front, you must be travelling at a minimum speed of 19 mph
- When following a vehicle, there is no minimum speed requirement

When following a vehicle, the system will automatically adjust your cruise speed based on the vehicle in front. It will even bring the vehicle to a complete stop if necessary.

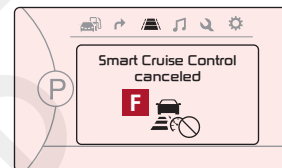
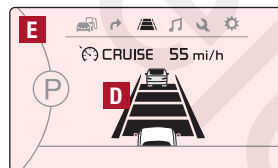

REMINDERS:

- Cruise Control button must be ON in order to turn ASCC ON/OFF
- ASCC system is activated when ignition is turned on. Speed will need to be reset when ignition is cycled on
- The distance settings are approximations and may vary depending on factory settings at the time. See owner's manual for more information

Audio Controls*

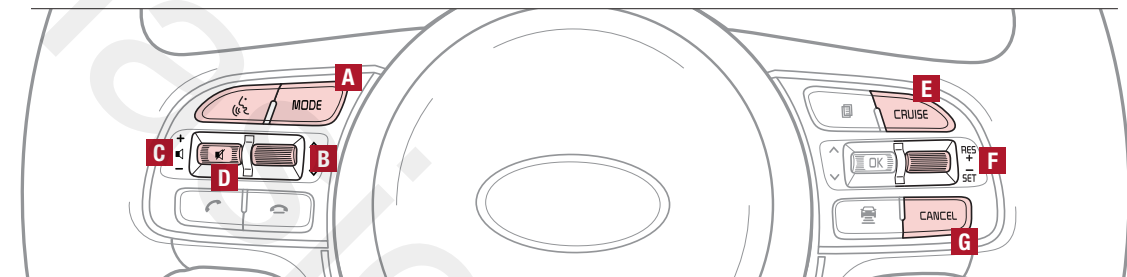

A Audio MODE button: Press to cycle through FM 1-2/AM/SAT 1-3/CD/USB/Aux/iPod®

Audio System ON/OFF: Press and hold to turn power on; Press to turn power off

B Seek/Preset button:

Radio Mode: Press to advance through Preset Stations. Press and hold to auto seek

Media Mode: Press to move Track Up/Down. Press & hold to FF/REW

C Volume button: Press up/down to raise/lower volume

D Mute button: Press to mute all audio

QUICK TIP

Pressing the Audio Mode button for more than 1 second will turn Audio Mode ON/OFF.

Driving while distracted is dangerous and should be avoided. Drivers should remain attentive to driving and always exercise caution when using the steering-wheel-mounted controls while driving.

For further audio system operations, refer to pages 22-23.

ALWAYS CHECK THE OWNER'S MANUAL FOR COMPLETE OPERATING INFORMATION AND SAFETY WARNINGS.

Cruise Control*

E CRUISE Control ON/OFF button: Press to turn the Cruise Control ON/OFF

F Resume Cruising Speed button: Press up to resume or increase Cruising Speed

F Set Cruising Speed button: Press down to set or decrease Cruising Speed

G Cruise Control CANCEL button: To cancel Cruise Control setting, do one of the following:

- Press the brake pedal
- Press the CANCEL button

QUICK TIPS

- Cruise Control is designed to function above 25 mph
- The Cruise Control system will not activate until the brake pedal has been depressed at least once after ignition ON or engine start

Your vehicle's steering wheel buttons may differ from those in the illustrations. See your Owner's Manual for more details.

*IF EQUIPPED

Standard Audio System*

– FM/AM/SiriusXM®/Media (CD, USB, iPod®, Aux, My Music, Bluetooth® Audio)*

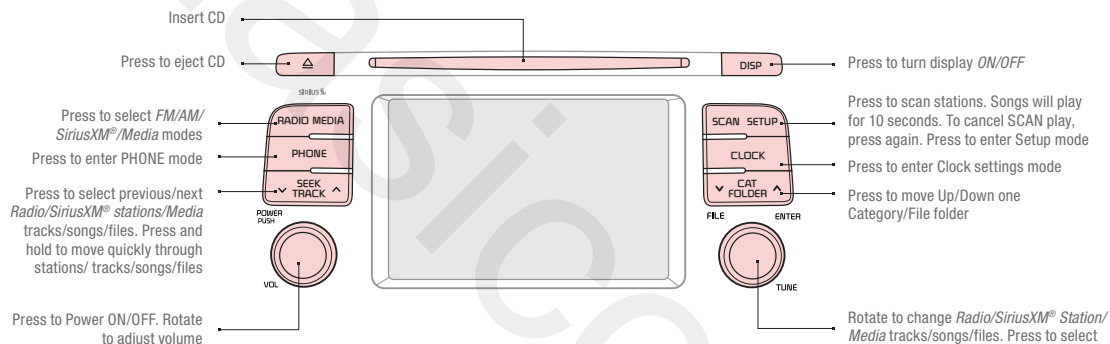

Your vehicle's audio system may differ from that in the illustration. See your Owner's Manual for more details. For further audio system operations, refer to page 23-25.

Audio System Setup Options

Press the SETUP key, then using the touchscreen, press the menu item to enter (Display, Sound, Clock/Calendar, Phone, System). Adjust the available settings for each equipped audio system setup option by pressing the onscreen buttons/arrows. Audio system setup options may include the following:

- **Display Setup** – Adjusting the Brightness, Mode Popup, Media Display
- **Sound Setup** – Sound Settings, Speed-Dependent Volume, Voice Recognition Volume, Touchscreen Beep
- **Clock/Calendar Setup** – Clock Settings, Calendar settings, Time Format, Clock Display
- **Phone Setup** – Pair Phone, Paired Phone List, Contacts Download, Auto Download, Outgoing Volume, Bluetooth® System off
- **System Setup** – Memory Information, Prompt Feedback, Language

Sound Settings:

To adjust the Standard Audio Systems sound settings:

1. Press the SETUP key on the audio control unit or the on-screen MENU button, when in MEDIA mode.
2. Select the on-screen SOUND button
3. Select the menu item (Sound Setting, Speed Dependent Volume, Voice Recognition Volume, Touch Screen Beep)
4. Using the touchscreen, press arrows to adjust the settings
5. Press the return arrow to save and exit

REMINDER: To help minimize driver distraction, some audio system functionalities have been modified while the vehicle is in Drive, Reverse or moved out of Park.

UVO eServices Setup*

UVO eServices Registration/Activation – To use UVO eServices:

1. On your Smartphone, go to an app store or marketplace to download the free Kia UVO eServices app.
2. Open the UVO eServices app and create an account by clicking on REGISTER. After entering your information and following the prompts to complete registration, go to your email and click on the confirmation link (You can also register an account by logging into MyUVO.com).
3. In the app, click CONTINUE, accept the terms and click CONTINUE once again.
4. Follow the app's IN-CAR SETUP instructions to connect your smartphone and complete UVO eServices activation.

Android Auto™*

Setting up Android Auto™:

1. From an Android Auto™ compatible device, download the Android Auto™ app from the Google Play™ Store.
2. Open the Android Auto™ app and proceed with the on-screen instructions to complete setup on the mobile device.

How to start Android Auto™:

1. Press the SETUP key on your UVO eServices system's control panel.
2. Press the CONNECTIVITY button, select Android Auto™ then select ENABLE ANDROID AUTO.
3. Connect the Android™ device with the vehicle's USB port using the manufacturer's cable provided with your phone.
4. From the vehicle's home screen, select the Android Auto™ button, where you'll see all the Android Auto™ supported apps.

Apple CarPlay®*

Setting up and starting Apple CarPlay®:

1. Connect the Apple CarPlay® compatible iPhone with the vehicle's USB port using the manufacturer's cable provided with your iPhone.
2. On the UVO eServices System audio control unit, press the SETUP key.
3. Press the CONNECTIVITY button on the screen and select Apple CarPlay®.
4. Select ENABLE APPLE CARPLAY.
5. From the vehicle's home screen, select the Apple CarPlay® button, where you'll see all the Apple CarPlay® supported apps

REMINDERS:

- Android Auto compatibility requirements: Micro-USB cable that came with your phone, OS Android™ 5.0 or higher, compatible Android smartphone and data and wireless plan for applicable feature(s).
- Apple CarPlay compatibility requirements: Apple Lightning cable, latest iOS software, iPhone 5 or later and data and wireless plan for applicable feature(s)

For further UVO eServices System operations, refer to the Car Multimedia System User's Manual. For other audio system information, refer to pages 22-25.

UVO eServices System*

– FM/AM/SiriusXM®/Media (USB, iPod®, Aux, *Bluetooth*® Audio, My Music, Pandora®)

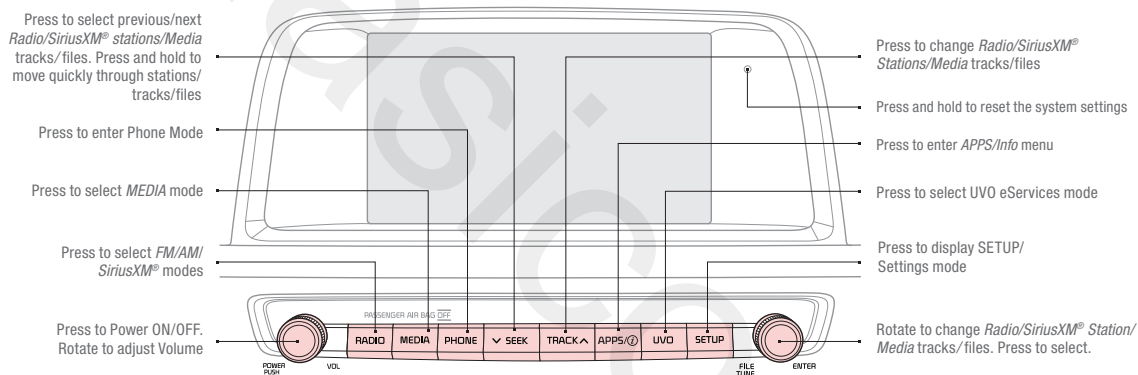

Sound Settings

To adjust the UVO eServices System sound settings:

1. Press the SETUP key on the audio control unit or the on-screen MENU button, when in MEDIA mode.
2. Select the on-screen SOUND button, or SOUND SETTINGS
3. Select the menu item (Position, Tone, Advanced, Default)
4. Use the onscreen buttons to adjust settings
5. Press the return button \Rightarrow to save settings

Your audio system may differ from those in the illustrations. For further navigation system operations, refer to the Car Multimedia System User's Manual. For further audio system operations, refer to pages 22-25.

REMINDER: To help minimize driver distraction, some audio system functionalities have been modified while the vehicle is in Drive, Reverse or moved out of Park.

QR CODE

UVO eServices System Videos

To view these videos on your mobile device, snap this QR Code or visit the listed website.

Refer to page 2 for more information.



www.KuTechVideos.com/audio/uvo3_eservices

QUICK TIPS

- Prolonged use of the navigation system in ACC mode may drain the vehicle's battery. A warning screen may appear periodically to remind users that the navigation system should be operated when the engine is running to prevent battery discharge
- When using the voice command feature, wait for the system BEEP before speaking the command
- A warning screen may appear periodically to remind users that the UVO eServices System should be operated when the engine is running to prevent battery discharge

UVO eServices with Premium Navigation*

– FM/AM/SiriusXM®/Media (USB, iPod®, Aux, Bluetooth® Audio, My Music, Pandora®)

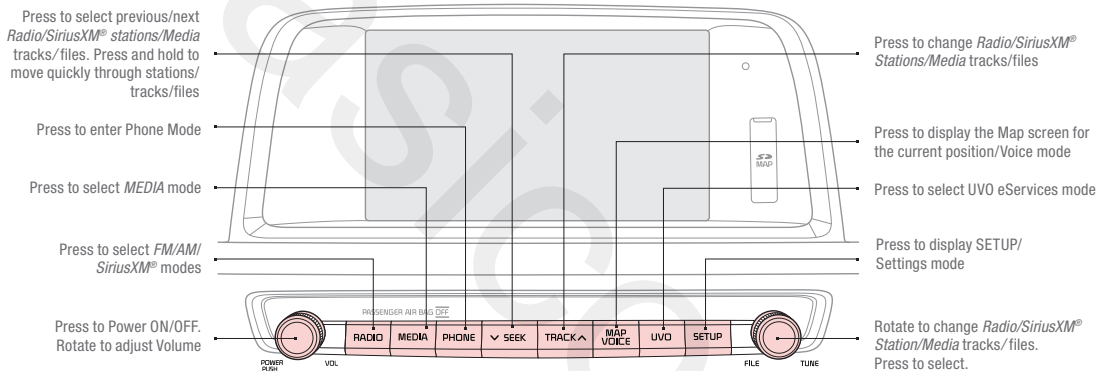

Sound Settings

To adjust the UVO eServices System sound settings:

1. Press the SETUP key on the audio control unit or the on-screen MENU button, when in MEDIA mode.
2. Select the on-screen SOUND button, or SOUND SETTINGS
3. Select the menu item (Position, Tone, Advanced, Default)
4. Use the onscreen buttons to adjust settings
5. Press the return button \Rightarrow to save settings

Your audio system may differ from those in the illustrations. For further navigation system operations, refer to the Car Multimedia System User's Manual. For further audio system operations, refer to pages 22-25.

REMINDER: To help minimize driver distraction, some audio system functionalities have been modified while the vehicle is in Drive, Reverse or moved out of Park.

QR CODE

UVO eServices with Premium Navigation Videos

To view these videos on your mobile device, snap this QR Code or visit the listed website.

Refer to page 2 for more information.



www.KuTechVideos.com/audio/avn4

QUICK TIPS

- Prolonged use of the navigation system in ACC mode may drain the vehicle's battery. A warning screen may appear periodically to remind users that the navigation system should be operated when the engine is running to prevent battery discharge
- When using the voice command feature, wait for the system BEEP before speaking the command
- A warning screen may appear periodically to remind users that the UVO eServices System should be operated when the engine is running to prevent battery discharge

Surround View Monitoring (SVM) System*





The Surround View Monitor (SVM) system is a parking support system that shows the areas around the front, rear, left, and right sides of the vehicle via four cameras displayed onto the navigation screen. The SVM system will turn on when the SVM button **A** is pressed and the LED is illuminated.

- The Front SVM camera is ON when the ENGINE START/STOP button is On, the gear shift is in Drive or Neutral and the SVM button is pressed ON
- **Rear SVM:** The camera view will automatically display on the navigation screen when the vehicle is shifted into Reverse. The camera view will turn off when the vehicle is shifted out of Reverse
- **Front SVM:** The camera view will display on the navigation screen in both Drive and Neutral. In Drive, the camera view will continue to display until the vehicle is above approximately 12 mph. The camera view will reappear on the navigation screen whenever the vehicle drops below approximately 12 mph





Camera View Modes – To change camera view modes, press the icons shown below on the navigation screen to select the mode.

REMINDER: The SVM camera is equipped with an optical lens to provide a wider range of vision and may appear different from the actual distance.

Front SVM - when in Drive & Neutral:

-  Displays the front side and SVM images simultaneously on the screen
-  Displays the front side image on the screen
-  Displays the front side and left side images simultaneously on the screen
-  Displays the front side and right side images simultaneously on the screen

Rear SVM - when in Reverse:

-  Displays the rear view and SVM images simultaneously on the screen
-  Displays the rear side image on the screen
-  Displays the rear and left side images simultaneously on the screen
-  Displays the rear and right side images simultaneously on the screen

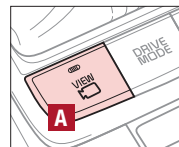

(Located below gear shift)



QR CODE

Surround View Monitor Video

To view a video on your mobile device, snap this QR Code or visit the listed website.

Refer to page 2 for more information.



www.KuTechVideos.com/f/13/2017

The Surround View Monitor system is only a supplemental device. Drivers should not rely solely on the SVM information when parking and backing up. Drivers should always pay attention and directly check the left/right and rear.

Digital Clock*

Standard Audio System Clock Setup:

Press the CLOCK key to display the Clock setting screen. Then use the on-screen buttons to navigate through setup and return \Rightarrow to exit.

UVO eServices / UVO eServices with Premium Navigation* Clock Setup:

Press the SETUP key, then the CLOCK button to display the Clock setting screen. Then use the on-screen buttons to navigate through setup and return \Rightarrow to exit. To access manual date and time setting, turn GPS time OFF in the Clock Settings (UVO eServices with Premium Navigation System*)

REMINDER: When needed, Daylight Savings must be enabled in the Clock Settings screen

Aux/USB/iPod® Port & Power Outlets

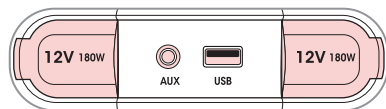

QUICK TIP

The power outlets are inactive when ignition is in the OFF position.

Use the Aux port to connect audio devices and the USB port to connect USB audio devices, smartphones and iPod® devices

REMINDER: Using the power outlet (accessory plug) for prolonged periods of time with the engine off could cause the battery to discharge.

For more information on the Aux/USB/iPod® Port & Power Outlets, refer to the Owner's Manual.

USB Charger*

The USB charger is located inside the Center Console and on rear of the Center Console **A**.

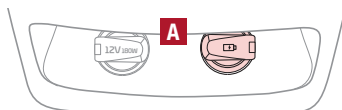

(Rear of Center Console shown)

ALWAYS CHECK THE OWNER'S MANUAL FOR COMPLETE OPERATING INFORMATION AND SAFETY WARNINGS.

Wireless Smartphone Charging System*

1. Slide open tray cover
2. Place smartphone on the center of the charging pad
3. Indicator light **B** will change to amber once the wireless charging begins
4. Once charging is complete, the orange light will change to green

Requires Qi enabled device or Qi enabled case

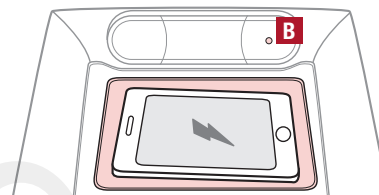

(Located in front of Gear Shift)

REMINERS:

- Avoid placing other metal items in the bin while charging as to not impede the charging area
- This vehicle is equipped with wireless charging technology which allows for a device to be charged using inductive charging, however, device compatibility varies. See your owner's manual for more detailed information and the back page for legal disclaimers
- Inductive charging systems are less efficient than conventional charging through cable. As a result, higher device operating temperatures may be experienced during use
- Charging Performance - Device position on the wireless charging system can affect charging performance. Other factor that may affect the charging rate includes foreign objects, such as coins or pens, and phone case thickness

QR CODE

Wireless Charging Video

To view a video on your mobile device, snap this QR Code or visit the listed website.

Refer to page 2 for more information.



www.KuTechVideos.com/jf13/2017

QUICK TIP

If wireless charging does not work, move smartphone around the pad until the charging indicator turns amber. Avoid placing other metal items in the bin while charging as to not impede the charging area.

Automatic Climate Control*

(Type B)

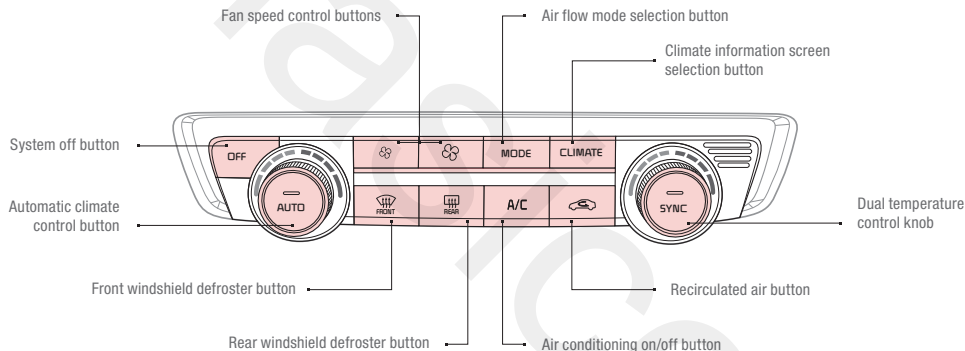

Climate Control Auto Function

1. Press AUTO to select Full Auto Operation. The Auto setting automatically controls the airflow modes, fan speeds, air intake and air conditioning according to the temperature setting selected.
2. Set desired Temperature
3. Press SYNC to synchronize driver and passenger temperature.

Defrost Outside Windshield:

1. Set Fan Speed to the highest position
2. Set Temperature to Hot
3. Press the Defrost button 

Defog Inside Windshield:

1. Set Fan Speed to desired position
2. Set desired Temperature
3. Press the Defrost button 

Air Flow Modes

To select Air Flow Modes, press the Mode selection buttons:



REMINDERS:

- Pressing any button during AUTO operation will deactivate the AUTO function and switch to manual mode, except for Temperature Control
- When in AUTO mode, Air Flow mode and Fan Speed do not display on the Climate Control Display
- Warm air may flow in through vents if Recirculated Air button is not pressed ON (LED lit)

Your Automatic Climate Control system may differ from those in the illustrations. See your Owner's Manual for more details.

QUICK TIPS

- Defrost mode  activates A/C and opens Fresh Air Vent to help dehumidify the air and improve Defroster performance
- During Auto Operation, the A/C indicator will NOT illuminate. The fan speed, air intake, air flow and air conditioning may automatically be engaged at any time to reach desired temperature and reduce humidity
- Keep inside glass as clean as possible to reduce window fogging

Manual Climate Control*

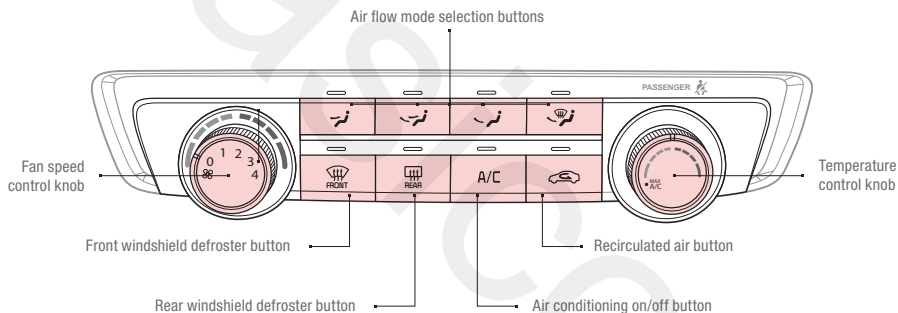

Defrost Outside Windshield:

1. Set Fan Speed to the highest position
2. Set desired Temperature
3. Press the Defrost button 

Defog Inside Windshield:

1. Set Fan Speed to desired position
2. Set desired Temperature
3. Press the Defrost button 

Your Manual Climate Control system may differ from those in the illustrations. See your Owner's Manual for more details.

Air Flow Modes

To select Air Flow Modes, press the Mode selection buttons:

-  Face-Level
-  Bi-Level
-  Floor-Level
-  Floor/Defrost-Level

QUICK TIPS

- Defrost mode activates A/C and opens Fresh Air Vent to help dehumidify the air and improve Defroster performance
- Keep inside glass as clean as possible to reduce window fogging

Electric Parking Brake (EPB)*

The Electric Parking Brake (EPB) system utilizes an electric motor to engage the parking brake.

Applying the Parking Brake

Depress the brake pedal and pull up the EPB switch. Ensure that the indicator light is illuminated on the instrument cluster.

Releasing the Parking Brake

The EPB will automatically release when the shifter is placed in Reverse or Drive.

To release EPB manually, depress the brake pedal, then press the EPB switch **A**, with the ignition switch in the ON position. Ensure that the indicator light is OFF.

REMINDERS:

- As a bulb check, the EPB malfunction indicator will illuminate for approximately 3 seconds when the ignition switch is turned ON
- If the warning light does not illuminate temporarily, or continues to remain lit, take your vehicle to an authorized Kia dealer and have the system checked
- The EPB should not be operated while the vehicle is moving
- A click or electric brake motor sound may be heard while operating or releasing the EPB, but these conditions are normal and indicates that the EPB is functioning properly

QUICK TIPS

- When leaving your keys with parking lot attendants or valet, make sure to inform them how to operate the EPB
- If parked on a steep incline, pull up the EPB switch for more than 3 seconds for a firmer EPB application
- Pull up and hold EPB switch a second time to increase brake pressure if parked on a decline or incline

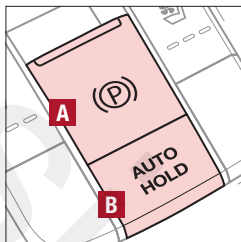

(Located below gear shift)

Auto Hold*

Auto Hold temporarily maintains the vehicle at a standstill even if the brake pedal is released. Auto Hold can be turned On/Off using the AUTO HOLD switch **B** on the center panel below gear shift. Before Auto Hold will operate, the driver's door, engine hood and trunk must be closed, and the driver's seat belt must be fastened.

The Auto Hold indicator on the Instrument Cluster has four states:

White: Standby - With vehicle at a standstill, and AUTO HOLD switch **B** is pressed On, the indicator will illuminate white. While driving the vehicle (vehicle is not at a standstill), the Auto Hold indicator will remain white.

Green: Engaged - When coming to a complete stop by depressing the brake pedal, the Auto Hold indicator changes from white to green.

Off (not illuminated) - The indicator will turn Off when the AUTO HOLD switch **B** is manually pressed Off or when the EPB is manually turned On.

Yellow: Malfunction - When the indicator is illuminated yellow, there may be a system malfunction. Take your vehicle to a local Kia dealer.

Refer to page 4 for location of Instrument Cluster indicators.

QR CODE

Electric Parking Brake (EPB) Video

To view a video on your mobile device, snap this QR Code or visit the listed website.

Refer to page 2 for more information.



www.KuTechVideos.com/jf113/2017

Automatic Gear Shift with Sportmatic® Shifting

P: Park

R: Reverse

N: Neutral

D: Drive

[+]: Sport Mode Upshift

[-]: Sport Mode Downshift

Sport Mode: To enter Sport mode, move shift lever from D to left gate.

To shift while in Sport mode, move shift lever up [+] to upshift or down [-] to downshift.

Paddle Shifters*

Paddle Shifters are operable when the shift lever is moved into the left gate of the D position (Sport mode).

Paddle Shifting: Pull the [+] or [-] paddle shifter once to shift up or down one gear.

REMINDERS:

- The Paddle Shifters can be operated when the vehicle speed is more than 6 mph
- When in Sport mode, pulling the left and right paddle shifters at the same time will NOT shift gears

QUICK TIPS

- Press brake pedal and depress release button to move gearshift from N to P, N to R or from P to any gear
- Sport mode downshifts are made automatically when the vehicle slows down. When the vehicle stops, 1st gear is automatically selected

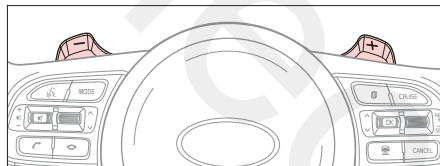
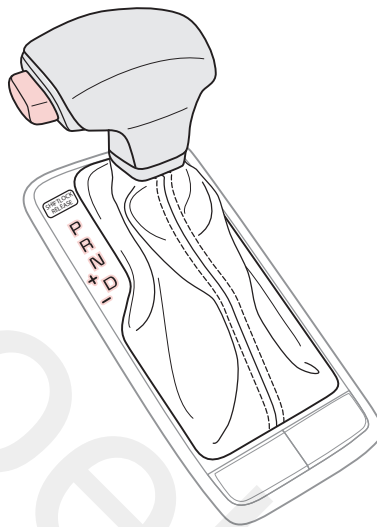

QR CODES

To view these videos on your mobile device, snap these QR Codes or visit the listed website.

Refer to page 2 for more information.

Sportmatic® Shifting Video



www.KuTechVideos.com/jf13/2017

Paddle Shifters Video



www.KuTechVideos.com/jf13/2017

Front Seat Headrest Adjustment

To raise headrest: Pull headrest up.

To lower headrest: Press lock **A**, then press the headrest down.

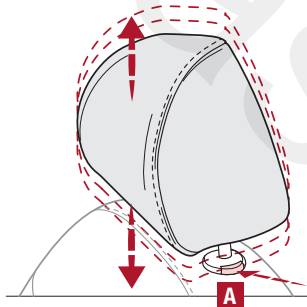

Power Adjustable Driver's Seat*

Move/Press controls to adjust Seat forward/backward, Seat Cushion tilt up/down, Seatback forward/backward or Lumbar up/down/forward/backward

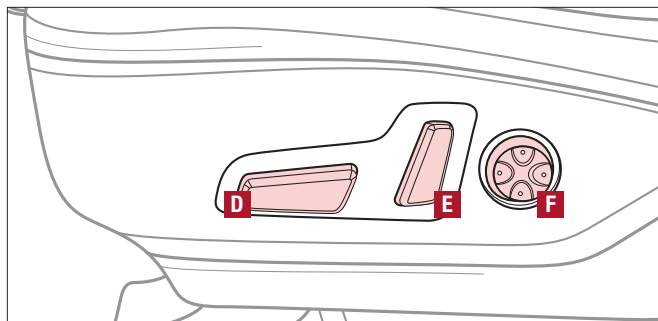

Driver Position Memory System*

To store a seating position into memory, first place the shifter into P (Park) while the ignition switch is ON. Then:

1. Adjust the driver's seat
2. Press the SET button **B** on the control panel. System will beep once
3. Press one of the memory buttons **C** within 5 seconds. The system will beep twice when memory has been stored
4. "Driver (1 or 2) set is memorized" will appear on the instrument cluster LCD screen

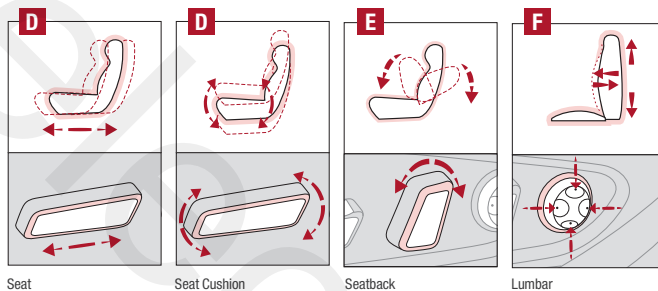
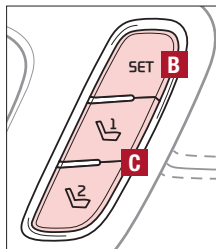

6-Way Manual Adjustable Driver's Seat

Pull lever **A** to slide Seat forward/backward.

Pull/press lever **B** to adjust Seat height.

Pull lever **C** to adjust Seatback recline.

Press **D** to adjust Lumbar support*

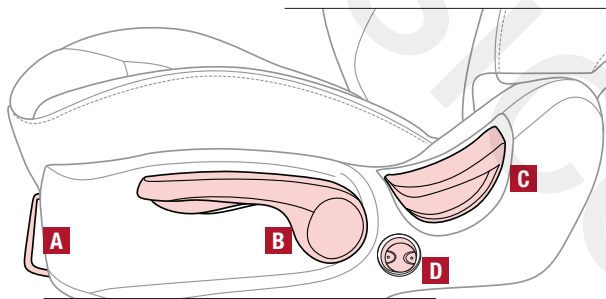

QUICK TIP

When adjusting seat forward or backwards, ensure seat clicks or locks into place before driving vehicle.

Seat Warmers*

Press button once for high setting (3 LEDs lit), again for medium setting (2 LEDs lit), again for low setting (1 LED lit) and again to turn OFF.

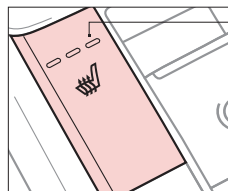

Yellow Color:
Warming

(Buttons located below gear shift)

Seat Warmers/Ventilated Seats*

Seat Warmers — Press top of button once for high setting (3 LEDs lit), again for medium setting (2 LEDs lit), again for low setting (1 LED lit) and again to turn OFF.

Ventilated Seats — Press setting (3 again for medium LEDs lit), bottom of button once for high setting (2 LEDs lit), again for low setting (1 LED lit) and again to turn OFF.

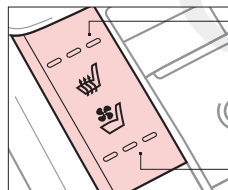

Yellow Color:
Warming

Blue Color:
Ventilating

(Buttons located below gear shift)

QR CODE

Heated and Ventilated Seats Video

To view a video on your mobile device, snap this QR Code or visit the listed website.

Refer to page 2 for more information.



www.KuTechVideos.com/jf13/2017

QUICK TIPS

- With the seat warmer switch in the ON position, the heating system in the seat turns OFF or ON automatically depending on the seat temperature
- System is OFF by default. To turn system ON again, press the Heated Steering Wheel button.

Smart Key*

Smart Key Fob:

- A** Press to lock All Doors
- B** Press to unlock Driver's Door. Press twice in 4 seconds to unlock All Doors
- C** Press and hold to unlock Trunk. Then lift by the handle to manually open Trunk.

REMINDER: The Trunk unlocks when the Smart Key fob is within close proximity of the vehicle.

- D** Press and hold more than 1 second for Panic Alarm. To turn off Alarm, press any button
- E** Press to release Mechanical Key (on reverse side of fob)

Driver's Door Lock/Unlock button **G**:

- Press button once to unlock Driver's Door
- Press again within 4 seconds to unlock All Doors
- Press again to lock All Doors

Mechanical Key **F**:

Use to unlock/lock Driver's Door

1. Remove door handle keyhole cover with Mechanical Key by pressing up into slot as shown
2. Insert Mechanical Key and turn right to Unlock Driver's Door. Turn twice within 4 seconds to Unlock all doors
3. Insert Mechanical Key and turn left to Lock Driver's Door
4. Return keyhole cover to its original position
Use to lock glove box and to turn Child Safety Locks

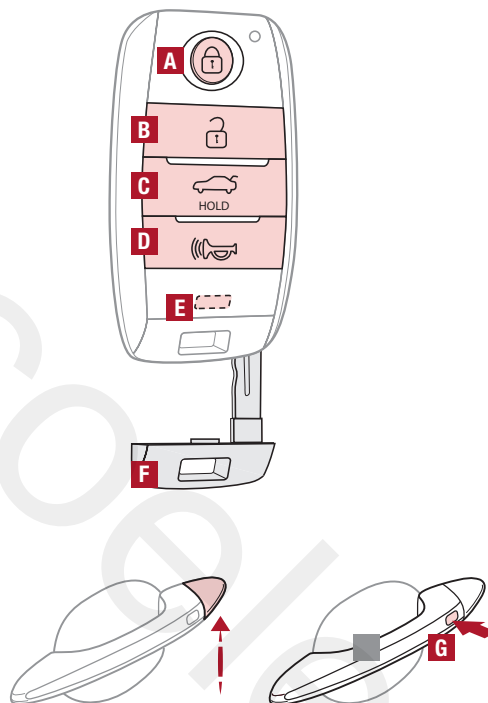

QUICK TIPS

- If the Smart Key battery is weak or not working properly, hold the Smart Key fob up to the ENGINE START/STOP button (Lock button side closest) and press to start engine
- The Smart Key's signal can be blocked by the normal operation of a cell phone or smartphone. To help prevent this, store each device separately

QR CODE

Engine Start/Stop Button & Smart Key Video

To view a video on your mobile device, snap this QR Code or visit the listed website.

Refer to page 2 for more information.



www.KuTechVideos.com/fj13/2017

REMINDER: Remote button configuration may vary depending on vehicle options

Remote Keyless Entry (Folding Key)*

- A** Press to release Folding Key
- B** Press to lock All Doors
- C** Press to unlock Driver's Door.
Press twice in 4 seconds to unlock All Doors
- D** Press and hold to unlock Trunk and manually open
- E** Press and hold more than 1 second for Panic Alarm. To turn off Alarm, press any button

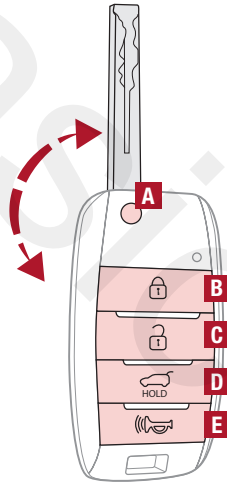

Remote button configuration may vary depending on vehicle options.

Double-Turn Lock/Unlock All

- Remove door handle keyhole cover with Mechanical Key by pressing up into slot as shown. Then insert Mechanical Key.
- Turn clockwise once to unlock Driver's Door
- Turn clockwise again within 4 seconds to unlock All Doors
- Turn counterclockwise once to lock All Doors

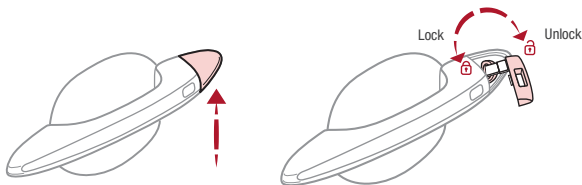

ALWAYS CHECK THE OWNER'S MANUAL FOR COMPLETE OPERATING INFORMATION AND SAFETY WARNINGS.

Fuel Cap/Malfunction Indicator (Check Engine Light)

Tighten for ONE CLICK to prevent Malfunction Indicator  from illuminating.

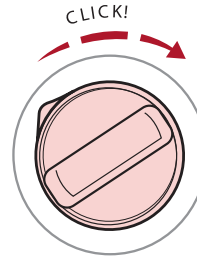

REMINDER: The Fuel Filler Door Release button is located on the lower part of the driver's door panel.

Sunvisor

Use the Sunvisor to shield direct light through the front or side windows. Slide the Sunvisor out and adjust as needed.

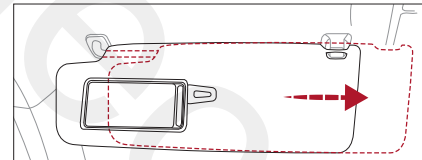

REMINDEES:

- Sunvisor may not shield all direct light
- Do not operate the vehicle if Sunvisor is impairing your visibility
- Be aware of your seating position when adjusting or swinging Sunvisor around from the front or side windows

QR CODE

One-Click Fuel Cap Video

To view a video on your mobile device, snap this QR Code or visit the listed website.

Refer to page 2 for more information.



www.KuTechVideos.com/jf13/2017

*IF EQUIPPED

Map/Room Lamps

Automatic turn off function*

The interior lights automatically turn off approximately 30 seconds after the ENGINE START/STOP button is OFF.

Map/Personal Lamp

Push the lens **A** to turn the Map Lamp ON/OFF. This light produces a spot beam for convenient use as a Map Lamp or Personal Lamp for the driver or front passenger.

Room Lamp

 : When pressed **B**, the lamp turns ON when any door is opened.

 : When pressed **C**, the lamp stays on continuously.

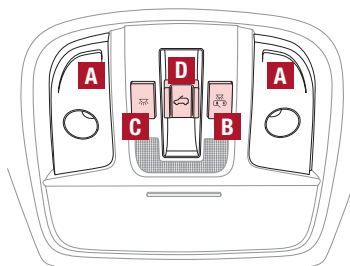

(Type B)

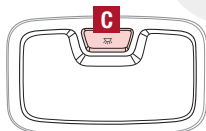

(Type A)

QUICK TIPS

- When doors are unlocked by the Smart Key*, the lamp turns ON for approximately 30 seconds
- If your vehicle is equipped with the theft alarm system, the interior lights automatically turn off approximately 3 seconds after the system is in armed stage
- Using interior lights for an extended period of time may cause battery discharge

Panoramic Sunroof Operation*

The Sunroof and Sunshade operation is controlled through a multi-directional switch/lever, and the ignition needs to be in the ON position to operate the Sunroof/Sunshade.

Slide the Sunshade and Sunroof:

- Auto Open: Slide lever backward to the farthest position and release
- Auto Close: Slide the lever **D** forward to the farthest position and release

Slide the Sunshade:

- Open: Slide the lever **D** partially backward to the first detent position
- Auto Close: Slide the lever **D** forward to the farthest or first detent position

Slide the Sunroof (with Sunshade open):

- Open: Slide the lever **D** backward and release
- Close: Slide the lever **D** partially forward to the first detent position

Tilt the Sunroof:

- Raise/Lower: Push lever **D** upward
- Auto Close: Slide the lever **D** forward to the farthest position

REMINDER: Sunshade needs to remain OPEN while Sunroof is open and vehicle is moving.

QUICK TIP

To stop the Sunroof/Sunshade at any position, push or pull the Sunroof control lever in any direction.

Fuel Door and Trunk Release

Press the button **A** to release the fuel door.

Pull the button **B** to open the trunk.

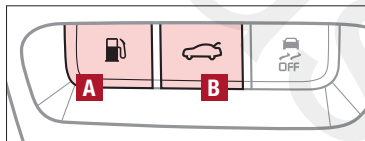

(Buttons located on Driver's Panel left of Steering Wheel)

Trunk Release Button (Exterior)

Located underneath the Trunk lid. With Trunk unlocked, press the Trunk Release button **C** and pull the Trunk lid up by the handle to open.

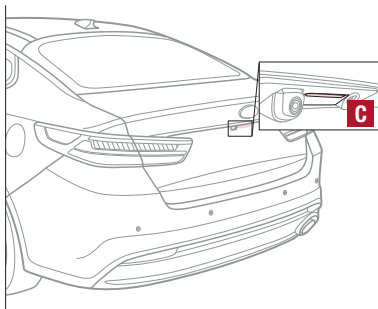

QUICK TIPS

- The Trunk must be unlocked before it can be opened by the Trunk Release Button
- Smart Key* - The Trunk unlocks automatically, and can then be opened manually, when the Smart Key fob* is within close proximity to the vehicle

Smart Trunk*

When the Smart Key fob is on your person and you are near the back of the vehicle, within close proximity, the hazard warning lights will blink and a chime will sound for about 3 seconds as an alert that the Smart Trunk* is about to open.

Then the alert system will blink and chime two additional times before opening the Smart Trunk*.

The Smart Trunk* feature is OFF by default. To enable the Smart Trunk*, go to User Settings in the LCD Instrument Cluster modes.

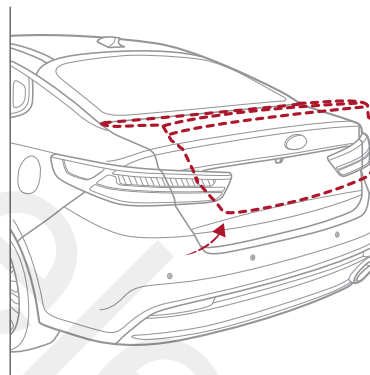

QUICK TIPS

During the Smart trunk alert, the Smart Trunk can be deactivated with the Smart Key by pressing any button on the key fob.

REMINDERS:

- All doors are closed and locked after about 15 seconds
- The Smart Trunk feature will not operate when the doors are recently closed and locked, and the Smart Key is still detected after 15 seconds near the vehicle or within 60 inches of the door handles, a door is not locked or closed or the Smart Key is in the vehicle

For more information on the Smart trunk operation, please refer to the Owner's Manual.

Hood Release Lever and Latch

Opening the Hood:

1. Pull the Hood Release Lever **A** to unlatch the Hood
2. In the front of the vehicle, lift the Hood slightly, pull the secondary Latch **B** inside of the Hood's center and lift the Hood

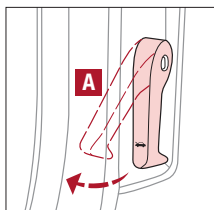

(Located on Driver side kick panel)

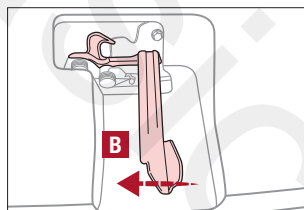

(Located inside of Hood's center)

Closing the Hood:

Lower the Hood about halfway and then press down to securely lock in place.

Child-Protector Rear Door Lock

Locate these locks on the rear edge of the rear passenger doors. Turn the safety lock to the LOCK position to disable the inner door handles from opening the rear doors.

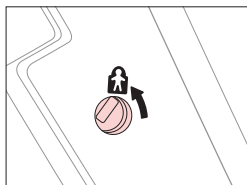

REMINDER: Child-Protector Rear Door Lock is located on rear passenger's door jamb.

Back-Up Warning System (Rear Parking Assist System)*

The Back-Up Warning System is not a safety device. The Back-Up Warning System is a supplemental system that assists the driver by chiming if any object is detected within the sensing area to the rear and side of the vehicle when backing up. When the ignition is ON, the system is activated.

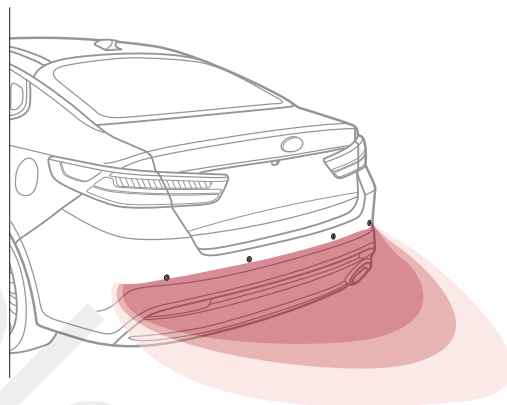

REMINDEES:

- If the vehicle is moving at speeds over 3 mph, the system may not activate correctly
- When more than two objects are sensed at the same time, the closest one will be recognized first

The Back-Up Warning System is not a substitute for proper and safe backing-up procedures. Always drive safely and use caution when backing up. The Back-Up Warning System may not detect every object behind the vehicle.

Rear-Camera Display*

The Rear-Camera Display system is not a safety device. It is a supplemental system that displays the view behind the vehicle through the UVO eServices with Premium Navigation system* screen while the vehicle is in Reverse.

The Rear-Camera Display activates when the:

- ENGINE START/STOP button* is in the ON position (green light)
- Gear Shift Lever is in the R (Reverse) position

REMINDER: While camera is active, only the volume controls on the audio system can be operated

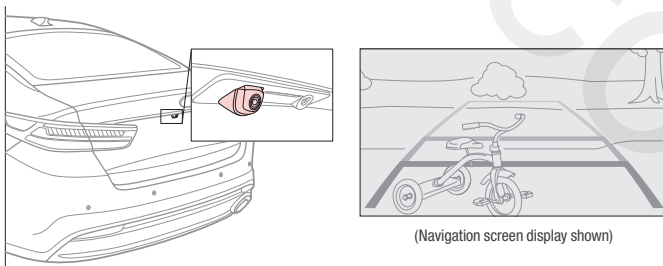

The Rear-Camera Display is not a substitute for proper and safe backing-up procedures. The Rear-Camera Display may not display every object behind the vehicle. Always drive safely and use caution when backing up.

Tire Mobility Kit*

The Tire Mobility Kit may temporarily seal certain types of tire damage.

For operational information, please refer to the Owner's Manual.

A Sealant Bottle

B Compressor

REMINDER: After tire is properly sealed, drive cautiously at a maximum speed of 50 mph for a maximum distance of up to 120 miles.

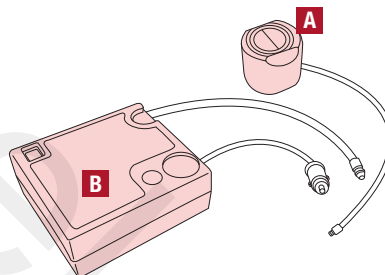

QR CODE

Tire Mobility Kit Video

To view a video on your mobile device, snap this QR Code or visit the listed website.

Refer to page 2 for more information.



www.KuTechVideos.com/jf13/2017

QUICK TIPS

- The Tire Mobility Kit is a temporary fix and is to be used for one tire only; the tire should be inspected as soon as possible
- The kit should only be used for sealing/inflating passenger car tires; do not use for inflating any other type of tires
- Some damaged tires cannot be sealed completely; do not use the kit if it appears a tire is damaged beyond repair

Occupant Detection System (ODS) / Passenger Air Bag Off Indicator

ODS detects the presence and position of the front passenger and adjusts or turns off airbag deployment accordingly.

Depending on the situation and type of accident, the system may:

- Deploy airbag (Adult)
- Not deploy the airbag (Unoccupied)



If the system determines that the airbag should not be deployed, the "PASSENGER AIR BAG OFF" light will illuminate.

Seat Belts

To properly fasten your safety belts:

1. Insert the belt tongue plate **A** into the buckle **B** until it clicks
2. Position the lap portion of the belt across your lap as **LOW ON THE HIPS** as possible **C**. Adjust the belt to a **SNUG FIT** by pulling up on the shoulder portion **D**

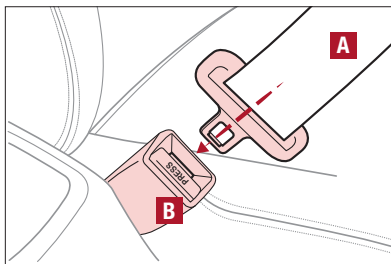

REMINDER: For maximum protection, always wear your Seat Belt.

QUICK TIP

The Seat Belt warning chime operates for driver's seat only.

Seat Belt Retractor Locks

Retractor locks allow lap/shoulder safety belts to remain unlocked during normal vehicle operation for freedom of movement and increased comfort.

During a **STRONG STOP, SUDDEN TURN OR CERTAIN COLLISIONS**, seat belt retractors will automatically lock the belts to help reduce the risk of injury.

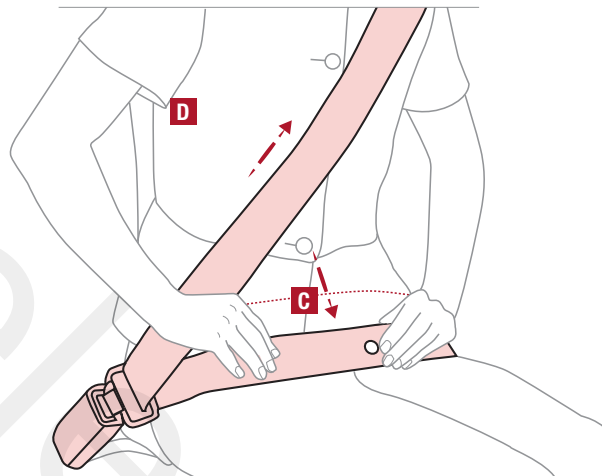

Normal Maintenance Schedule

When your vehicle requires service, remember that your dealer knows your vehicle best. Your dealer has factory-trained technicians, recommended special tools, genuine Kia replacement parts and is dedicated to your complete satisfaction. For expert advice and quality service, see your authorized Kia dealer.

7,500 miles

PERFORM

- Add fuel additive¹
- Rotate tires - including tire pressure and tread wear

REPLACE

- Engine oil and filter (2.4 GDI - every 7,500 miles; 1.6 Turbo GDI / 2.0 Turbo GDI - at first, replace at 3,000 miles, then every 5,000 miles)

INSPECT*

- Air cleaner filter
- Vacuum hose
- Intercooler, in/out hose, air intake hose (Turbo GDI)

*Inspect and, if necessary, adjust, correct, clean, or replace.

¹ If TOP TIER Detergent Gasoline is not available, one bottle of additive is recommended. Additives are available from your authorized Kia dealer along with information on how to use them. Do not mix other additives.

15,000 miles

PERFORM

- Add fuel additive¹
- Rotate tires - including tire pressure and tread wear

REPLACE

- Climate control air filter (For evaporator and blower unit)
- Engine oil and filter (2.4 GDI - every 7,500 miles; 1.6 Turbo GDI / 2.0 Turbo GDI - at first, replace at 3,000 miles, then every 5,000 miles)

INSPECT*

- | | |
|---|---|
| <ul style="list-style-type: none"> • Air cleaner filter • Vacuum hose • Air conditioning refrigerant • Brake hoses and lines • Drive shafts and boots • Exhaust pipe and muffler • Front brake disc/pads, calipers | <ul style="list-style-type: none"> • Rear brake disc/pads • Steering gear box, linkage & boots/lower arm ball joint, upper arm ball joint • Suspension mounting bolts • Intercooler, in/out hose, air intake hose (Turbo GDI) |
|---|---|

*Inspect and, if necessary, adjust, correct, clean, or replace.

¹ If TOP TIER Detergent Gasoline is not available, one bottle of additive is recommended. Additives are available from your authorized Kia dealer along with information on how to use them. Do not mix other additives.

QUICK TIP

Check your Maintenance Schedule or schedule an appointment with a dealer using your UVO eServices account by logging into your UVO App or your account on MyUVO.com (Vehicles equipped with UVO eServices only - See page 23 for setup information)

MAINTENANCE

22,500 miles

PERFORM

- Add fuel additive¹
- Rotate tires - including tire pressure and tread wear

REPLACE

- Engine oil and filter (2.4 GDI - every 7,500 miles; 1.6 Turbo GDI / 2.0 Turbo GDI - at first, replace at 3,000 miles, then every 5,000 miles)

INSPECT*

- Air cleaner filter
- Vacuum hose
- Intercooler, in/out hose, air intake hose (Turbo GDI)

*Inspect and, if necessary, adjust, correct, clean, or replace.

¹ If TOP TIER Detergent Gasoline is not available, one bottle of additive is recommended. Additives are available from your authorized Kia dealer along with information on how to use them. Do not mix other additives.

30,000 miles

PERFORM

- Add fuel additive¹
- Rotate tires - including tire pressure and tread wear

REPLACE

- Engine oil and filter (2.4 GDI - every 7,500 miles; 1.6 Turbo GDI / 2.0 Turbo GDI - at first, replace at 3,000 miles, then every 5,000 miles)
- Air cleaner filter
- Climate control air filter (For evaporator and blower unit)

INSPECT*

- Vacuum hose
- Air conditioning refrigerant
- Brake hoses and lines
- Drive shafts and boots
- Exhaust pipe and muffler
- Front brake disc/pads, calipers
- Rear brake disc/pads
- Steering gear box, linkage & boots/lower arm ball joint, upper arm ball joint
- Suspension mounting bolts
- Brake fluid
- Fuel filter²
- Fuel cap, fuel lines, fuel hoses and connections
- Fuel tank air filter² (if equipped)
- Parking brake
- Vapor hose and fuel filler cap
- Intercooler, in/out hose, air intake hose (Turbo GDI)

*Inspect and, if necessary, adjust, correct, clean, or replace.

¹ If TOP TIER Detergent Gasoline is not available, one bottle of additive is recommended. Additives are available from your authorized Kia dealer along with information on how to use them. Do not mix other additives. ² Fuel filter & Fuel tank filter are considered to be maintenance free but periodic inspection is recommended for this maintenance schedule depends on fuel quality. If there are some important safety matters like fuel flow restriction, surging, loss of power, hard starting problem etc, replace fuel filter immediately regardless of maintenance schedule and consult an authorized Kia dealer for details.

MAINTENANCE

37,500 miles

PERFORM

- Add fuel additive¹
- Rotate tires - including tire pressure and tread wear

REPLACE

- Engine oil and filter (2.4 GDI - every 7,500 miles; 1.6 Turbo GDI / 2.0 Turbo GDI - at first, replace at 3,000 miles, then every 5,000 miles)

INSPECT*

- Air cleaner filter
- Vacuum hose
- Intercooler, in/out hose, air intake hose (Turbo GDI)

*Inspect and, if necessary, adjust, correct, clean, or replace.

¹ If TOP TIER Detergent Gasoline is not available, one bottle of additive is recommended. Additives are available from your authorized Kia dealer along with information on how to use them. Do not mix other additives.

45,000 miles

PERFORM

- Add fuel additive¹
- Rotate tires - including tire pressure and tread wear

REPLACE

- Engine oil and filter (2.4 GDI - every 7,500 miles; 1.6 Turbo GDI / 2.0 Turbo GDI - at first, replace at 3,000 miles, then every 5,000 miles)
- Spark plugs (Iridium coated; 1.6 Turbo GDI / 2.0 Turbo GDI)
- Climate control air filter (For evaporator and blower unit)

INSPECT*

- Air cleaner filter
- Vacuum hose
- Air conditioning refrigerant
- Brake hoses and lines
- Drive shafts and boots
- Exhaust pipe and muffler
- Front brake disc/pads, calipers
- Rear brake disc/pads
- Steering gear box, linkage & boots/lower arm ball joint, upper arm ball joint
- Suspension mounting bolts
- Intercooler, in/out hose, air intake hose (Turbo GDI)

*Inspect and, if necessary, adjust, correct, clean, or replace.

¹ If TOP TIER Detergent Gasoline is not available, one bottle of additive is recommended. Additives are available from your authorized Kia dealer along with information on how to use them. Do not mix other additives.

MAINTENANCE

52,500 miles

PERFORM

- Add fuel additive¹
- Rotate tires - including tire pressure and tread wear

REPLACE

- Engine oil and filter (2.4 GDI - every 7,500 miles; 1.6 Turbo GDI / 2.0 Turbo GDI -then every 5,000 miles)

INSPECT*

- Air cleaner filter
- Vacuum hose
- Intercooler, in/out hose, air intake hose (Turbo GDI)

*Inspect and, if necessary, adjust, correct, clean, or replace.

¹ If TOP TIER Detergent Gasoline is not available, one bottle of additive is recommended. Additives are available from your authorized Kia dealer along with information on how to use them. Do not mix other additives

60,000 miles

PERFORM

- Add fuel additive¹
- Rotate tires - including tire pressure and tread wear

REPLACE

- Climate control air filter (for evaporator and blower unit)
- Engine oil and filter (2.4 GDI - every 7,500 miles; 1.6 Turbo GDI / 2.0 Turbo GDI - at first, replace at 3,000 miles, then every 5,000 miles)
- Coolant (First at 60,000 miles, then every 30,000 miles)

INSPECT*

- Vacuum hose
- Air conditioning refrigerant
- Brake hoses and lines
- Drive shafts and boots
- Exhaust pipe and muffler
- Front brake disc/pads, calipers
- Rear brake disc/pads
- Steering gear box, linkage & boots/lower arm ball joint, upper arm ball joint
- Suspension mounting bolts
- Brake fluid
- Fuel filter²
- Fuel cap, fuel lines, fuel hoses and connections
- Fuel tank air filter (if equipped)²
- Parking brake
- Vapor hose and fuel filler cap, fuel tank
- Valve clearance (if equipped)³
- Drive belts (First at 60,000 miles, then every 15,000 miles)
- Intercooler, in/out hose, air intake hose (Turbo GDI - every 6,200 miles)

*Inspect and, if necessary, adjust, correct, clean, or replace.

¹ If TOP TIER Detergent Gasoline is not available, one bottle of additive is recommended. Additives are available from your authorized Kia dealer along with information on how to use them. Do not mix other additives. ² Fuel filter & Fuel tank filter are considered to be maintenance free but periodic inspection is recommended for this maintenance schedule depends on fuel quality. If there are some important safety matters like fuel flow restriction, surging, loss of power, hard starting problem etc, replace fuel filter immediately regardless of maintenance schedule and consult an authorized Kia dealer for details. ³ Inspect for excessive tappet noise and/or engine vibration and adjust if necessary.

LEGAL DISCLAIMERS

Driving while distracted is dangerous and should be avoided. Drivers should remain attentive to driving and always exercise caution when using the steering-wheel-mounted controls while driving.

Driving while distracted can result in a loss of vehicle control that may lead to an accident, severe personal injury and death. The driver's primary responsibility is in the safe and legal operation of a vehicle, and use of any handheld devices, other equipment or vehicle systems which take the driver's eyes, attention and focus away from the safe operation of a vehicle or that are not permissible by law should never be used during operation of the vehicle.

Safety Features: No system, no matter how advanced, can compensate for all driver error and/or driving conditions. Always drive responsibly.

Airbags: For maximum protection, always wear your seat belt.

Android Auto™: Android Auto is a trademark of Google, Inc. Android™ is a registered trademark of Google, Inc. Distracted driving can result in a loss of vehicle control. Never use a handheld device or vehicle system that takes your focus away from safe vehicle operation. Navigation is for information purposes only, and Kia does not make any warranties about the accuracy of the information.

Apple CarPlay®: Apple CarPlay® a registered trademark of Apple Inc. Distracted driving can result in a loss of vehicle control. Never use a handheld device or vehicle system that takes your focus away from safe vehicle operation. Navigation is for information purposes only, and Kia does not make any warranties about the accuracy of the information.

Apps: All information contained herein was based upon the latest available information at the time of appstore registration. Descriptions are believed to be correct, and Kia makes every effort to ensure accuracy; however, accuracy cannot be guaranteed. From time to time, Kia may need to update or make changes to the vehicle features and other vehicle information reported in this app. Kia, by the publication and dissemination of this material, does not create any warranties, either express or implied, to any Kia products. Contact your local Kia dealer for the most current information.

Autonomous Emergency Braking System (AEB) / Forward Collision Warning System: These systems are not substitutes for safe driving, and may not detect all objects in front of vehicle. Always drive safely and use caution.

Bluetooth® Wireless Technology: The Bluetooth® word mark and logos are registered trademarks owned by Bluetooth SIG Inc., and any use of such marks by Kia is pursuant to license. A Bluetooth® enabled cell phone is required to use Bluetooth® wireless technology.

Driver Assist Features - Blind Spot Detection (BSD) with Lane Change Assist, Rear Cross Traffic Alert (RCTA), Lane Departure Warning System, Rear-Camera Display: These features are not substitutes for safe driving, and may not detect all objects surrounding vehicle. Always drive safely and use caution.

Electronic Stability Control (ESC) / Traction Control System (TCS)/Hill-start Assist Control (HAC): No system, no matter how advanced, can compensate for all driver error and/or driving conditions. Always drive responsibly.

Engine Start/Stop Button with Smart Key: Always come to a complete stop before turning the engine on or off. However, if you have an emergency while the vehicle is in motion and must turn the engine off, you can turn the engine off to the ACC position by pressing the Start/Stop button for more than 3 seconds or 3 times in succession. If the vehicle is still moving, you can restart the engine by pressing the Start/Stop button with the shift lever in Neutral (N). With the engine off, hydraulic power assist for steering and braking will be disabled and the vehicle will be more difficult to control.

Front Seat Headrest Adjustment: Never attempt to adjust headrests when vehicle is in motion.

Google Play™ Store is a trademark of Google, Inc. © 2012 Google Inc. All rights reserved. Google and the Google Logo are registered trademarks of Google Inc.

HomeLink®: Homelink® is a registered trademark of Gentex Corporation

iPod® is a registered trademark of Apple Inc. iPod® mobile digital device sold separately, and connectivity requires the Kia accessory cable.

Navigation: Distracted driving can result in a loss of vehicle control. When operating a vehicle, never use a vehicle system that takes your focus away from safe vehicle operation. Navigation is for information purposes only, and Kia does not make any warranties about the accuracy of the information.

Occupant Detection System (ODS): Kia vehicles use a number of different ODS types that vary by model.

Pandora® internet radio: Pandora® is a registered trademark of Pandora Media, Inc.

Roadside Assist: 24-hour Enhanced Roadside Assistance is a service plan provided by Kia Motors America, Inc. Certain limitations apply. Coverage details are available in the Kia Warranty and Consumer Information Manual. For access to Enhanced Roadside Assistance, a connected mobile phone via Bluetooth® within the cellular service coverage area is required.

Seat adjustments: Reclining the passenger seats can reduce the effectiveness of the safety restraint system and may lead to additional injury in an accident.

Seat belts: For maximum protection, always wear your seatbelt.

Seat warmers: Use extreme caution when using the seat warmers to avoid burns. Refer to the Owner's Manual for more information.

SiriusXM®: SiriusXM Satellite Radio, SiriusXM Traffic and SiriusXM Travel Link each require a subscription sold separately, or as a package, by SiriusXM Radio Inc. **If you decide to continue your service at the end of your trial subscription, the plan you choose will automatically renew and bill at then-current rates until you call 1-866-635-2349 to cancel. See SiriusXM Customer Agreement for complete terms at www.siriusxm.com.** Other fees and taxes will apply. All fees and programming are subject to change. Not all vehicles or devices are capable of receiving all services offered by SiriusXM. Data displays and individual product availability vary by vehicle hardware. Current information and features may not be available in all locations, or on all receivers. Weather Forecast, Current Conditions may not be available in all locations. Images above are for representative purposes only and are not real products. For actual features and images of real products, consult the vehicle manufacturer. SiriusXM is not responsible for any errors or inaccuracies in the data services or their use in the vehicle. Travel Link Stocks displays current price and daily delta of around 7,000 actively reported securities traded on the NYSE®, NASDAQ® and AMEX®. The service is delayed approximately 20 minutes. SiriusXM satellite service is available only to those at least 18 years of age in the 48 contiguous USA, DC, and Puerto Rico (with coverage limitations). SiriusXM Internet Radio service is available throughout our satellite service area and in AK and HI. © 2016 SiriusXM Radio Inc. Sirius, XM and all related marks and logos are trademarks of SiriusXM Radio Inc.

Power Liftgate (Tailgate)* / Smart Liftgate®: Driving with the liftgate open may be unlawful and can draw dangerous exhaust fumes into your vehicle; if you choose to do so, keep air vents and all windows open for proper ventilation.

Sportmatic® is a registered trademark of Kia Motors America.

Steering-wheel-mounted controls: Driving while distracted is dangerous and should be avoided. Remain attentive to driving and be cautious when using steering-wheel-mounted controls while driving.

Sunvisors: Sunvisor may not shield all direct light. Do not operate the vehicle if sunvisor is impairing your visibility.

Tilt/Telescoping Steering Wheel: Never attempt to adjust steering wheel position when vehicle is in motion.

Tire Pressure Monitoring System (TPMS): Even with Tire Pressure Monitoring System, check tire pressure on a regular basis.

UVO eServices: Distracted driving can result in a loss of vehicle control. Never use a handheld device or vehicle system that takes your focus away from safe vehicle operation.

UVO eServices app: App uses your smartphone data service. Normal cellular service rates will apply.

UVO eServices with Premium Navigation: Distracted driving can result in a loss of vehicle control. Never use a handheld device or vehicle system that takes your focus away from safe vehicle operation. Navigation is for information purposes only, and Kia does not make any warranties about the accuracy of the information.



© 2016 Kia Motors America, Inc. All rights reserved.

Part Number: UT170-PS-004

Consumer - Roadside Assistance: 1-800-333-4KIA (4542)



KEY FEATURE WALKTHROUGH

Demonstrate the following with the customer

- Standard Audio System (Type B)*
– page 22
For more information, refer to the Owner's Manual.



- UVO eServices with Premium Navigation* – page 25
For more information, refer to the Car Multimedia System User's Manual.

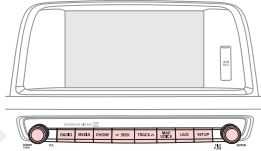

- Wireless Smartphone Charging System* – page 27

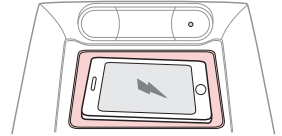

- Cruise Control* – page 21
Demonstrate operation.

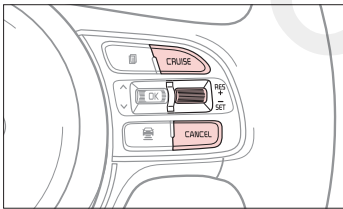

- Bluetooth® Wireless Technology* – page 18
Demonstrate operation.

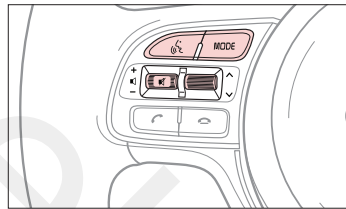

- Active ECO System* – page 9
- Tire Pressure Monitoring System (TPMS) – page 5
- Engine Start/Stop Button* – page 13
- Aux/USB/iPod® Port – page 27
- Digital Clock – page 27
- Seat Warmers/Ventilated Seats* – page 33
- Sunvisor – page 35

- Panoramic Sunroof Operation* – page 36
- Rear-Camera Display* – page 39
- Smart Key* – page 34
- Back-Up Warning System* – page 38
- Passenger Airbag Off Indicator – page 40
- Tire Mobility Kit* – page 39

*IF EQUIPPED

DURING DELIVERY

- Explain first service process and schedule first service appointment
- Tour Parts & Service departments, introduce staff & explain value of Kia Parts and Service
- Review recommended maintenance schedule and maintenance requirements to validate warranty
- Review business hours & Customer 360° Care
- Review the Kia 10-year/100,000-mile warranty program
- Ensure 100% satisfaction with sales and delivery process and no problems with the vehicle
- Confirm time and best contact number for initial dealer follow-up

Sales Consultant: _____ Date: _____

Sales Manager: _____ Date: _____

Customer: _____ Date: _____



OPTIMA CUSTOMER DELIVERY CHECKLIST

Owner's Name: _____ VIN: _____ Mileage: _____

Dealership Name: _____ Sales Consultant: _____ Date: _____

BEFORE DELIVERY

- Confirm "Good Battery" with Kia GR8-1299 battery tester
- Verify all tire pressures are to spec (see driver's door label) LF _____ LR _____ RF _____ RR _____
- Verify proper operation of Remote Keyless Entry and Smart Key lock/unlock
- Ensure floor mats are snapped into place (if applicable)
- Verify vehicle is clean (interior and exterior), in good condition and free of chips and scratches
- Ensure all key documents are in the vehicle (Owner's Manual, Warranty and Consumer Information booklet, Tire Warranty booklet and Features & Functions Guide and any supplemental audio user's guides)

KEY FEATURE WALKTHROUGH

- Air Conditioning / Climate Control – pages 28 - 29
Demonstrate Air Flow modes, Defog and Defrosting Windshield.

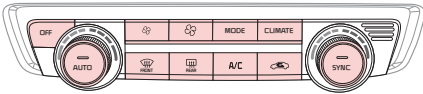

Automatic Climate Control

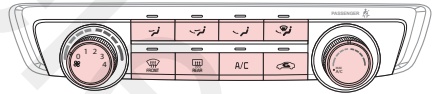

Manual Climate Control

- Electric Parking Brake (EPB)* and Auto Hold* – page 30
Demonstrate operation.



- Windshield Wipers & Washers* – page 16

- To operate:
- Move lever Up/Down to change Wiper modes
 - Press switch Up/Down to adjust Intermittent Wipe Speed
 - Pull lever to spray and wipe

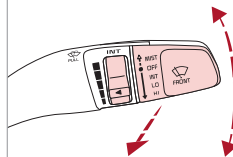

- MIST:** Single wipe
- OFF:** Wiper off
- INT:** Intermittent wipe
- LO:** Slow wipe
- HI:** Fast wipe