



**MITO**

OWNER HANDBOOK

This Owner Handbook illustrates the operating instructions of the car.

Alfa Romeo provides a dedicated section available in electronic format for enthusiasts who want insights, curiosities and detailed information about the features and functions of the car.

### **ONLINE OWNER HANDBOOK**

The  **eLUM** symbol appears in the Owner Handbook next to topics for which updates are available.

Go to [elum.alfaromeo.com](http://elum.alfaromeo.com) where you will find all the details of the Owner Handbook.

Alternatively, to access this information, go to the Internet website at <http://aftersales.fiat.com/elum/>.

The **eLUM** website is free and conveniently allows you to browse the on-board documents of all other models of the Group, among many other things.

Have a nice read and happy motoring!

**Dear Customer,**

We would like to congratulate and thank you for choosing an Alfa Romeo.

We have written this handbook to help you get to know all the features of your vehicle and use it in the best possible way.

Here you will find information, advice and important warnings regarding use of your vehicle and how to achieve the best performance from the technical features of your Alfa Mito.

You are advised to read it right through before taking to the road for the first time, to become familiar with the controls and above all with those concerning brakes, steering and gearbox; at the same time, you can understand the vehicle behaviour on different road surfaces.

This document also provides a description of special features and tips, as well as essential information for the safe driving, care and maintenance of your Alfa Mito over time.

In the attached Warranty Booklet you will also find the description of the Services that Alfa Romeo offers to its customers, the Warranty Certificate and the detail of the terms and conditions for maintaining its validity.

We are sure that these will help you to get in touch with and appreciate your new car and the service provided by the people at Alfa Romeo.

Enjoy reading. Happy motoring!

# READ THIS CAREFULLY

## REFUELLING



**Petrol engines:** only refuel with unleaded petrol with octane rating (RON) not less than 95 in compliance with the European specification EN228.  
**Diesel engines:** refuel only with Diesel fuel motor vehicles conforming to the European specification EN590. The use of other products or mixtures may damage the engine beyond repair and consequently invalidate the warranty, due to the damage caused.

## STARTING THE ENGINE



**Petrol engines.** *Versions with manual gearbox* engage the handbrake, set the gear lever to neutral; fully depress the clutch pedal without pressing the accelerator, then turn the ignition key to AVV and release it as soon as the engine has started. *Versions with TCT gearbox* (if available), engage the handbrake and set the gear lever in P (Parking) or N (Neutral), then turn the ignition key to AVV and release it as soon as the engine is started. **Diesel engines:** turn the ignition key to MAR and wait for the  warning light to switch off. Then turn the ignition key to AVV and release it as soon as the engine has started.

## PARKING ON FLAMMABLE MATERIAL



The catalytic converter develops high temperatures during operation. Do not park the car on grass, dry leaves, pine needles or other flammable material: fire hazard.

## RESPECTING THE ENVIRONMENT



The vehicle is fitted with a system that carries out a continuous diagnosis of the emission-related components in order to help protect the environment.

## ELECTRICAL ACCESSORIES



If, after buying the car, you decide to add electrical accessories (with the risk of gradually draining the battery), contact an Alfa Romeo Dealership. They will calculate the overall electrical requirement and check that the car's electrical system can support the required load.



## SCHEDULED SERVICING



Correct maintenance of the car is essential for ensuring that it maintains its performance and its safety features, its environmental friendliness and low running costs for a long time to come.

## THE OWNER HANDBOOK CONTAINS



... important information, advice and warnings for correct use, driving safety and maintenance of the car over time. Special attention must be paid to the symbols  (personal safety)  (environmental protection)  (car integrity).

## USE OF THE OWNER HANDBOOK

Each time direction instructions (left/right or forwards/backwards) about the vehicle are given, these must be understood as regarding an occupant in the driver's seat. Special cases not complying with this rule will be specified as appropriate in the text.

The figures in the Owner Handbook are provided by way of example only: this might imply that some details of the image do not correspond to the actual arrangement of your vehicle. In addition, the Handbook has been conceived considering vehicles with steering wheel on the left side; it is therefore possible that on vehicles with steering wheel on the right side, the position or construction of some controls is not exactly mirror-like with respect to the figure.

To identify the chapter with the information needed you can consult the index at the end of this Owner Handbook.

Chapters can be rapidly identified with dedicated graphic tabs, at the side of each odd page. A few pages further there is a key for getting to know the chapter order and the relevant symbols in the tabs. There is in any case a textual indication of the current chapter at the side of each even page.

## WARNINGS AND PRECAUTIONS

While reading this Owner Handbook you will find a series of **WARNINGS** to prevent procedures that could damage your vehicle.

There are also **PRECAUTIONS** that must be carefully followed to prevent incorrect use of the components of the vehicle, which could cause accidents or injuries.

Therefore all **WARNINGS** and **PRECAUTIONS** must always be carefully followed.

**WARNINGS** and **PRECAUTIONS** are recalled in the text with the following symbols:



personal safety;



vehicle safety;



environmental protection.

NOTE These symbols, when necessary, are indicated besides the title or at the end of the line and are followed by a number. That number recalls the corresponding warning at the end of the relevant section.

## IMPORTANT

**This Owner Handbook describes all Alfa Mito versions. Options, equipment dedicated to specific markets or versions are not explicitly indicated in the text: as a consequence, you should only consider the information which is related to the trim level, engine and version that you have purchased. Any content introduced throughout the production of the model, outside the specific request of options at the time of purchase, will be identified with the wording (*where provided*).**

**All data contained in this publication are intended to help you use your vehicle in the best possible way. FCA Italy S.p.A. aims at a constant improvement of the vehicles produced. For this reason it reserves the right to make changes to the model described for technical and/or commercial reasons.**

**For further information, contact an Alfa Romeo Dealership.**

## VEHICLE CHANGES / ALTERATIONS



**IMPORTANT** Any change or alteration of the vehicle might seriously affect its safety and road holding, thus causing accidents, in which the occupants could even be fatally injured.

**GETTING TO KNOW YOUR CAR**



**KNOWING THE INSTRUMENT PANEL**



**SAFETY**



**STARTING AND DRIVING**



**IN AN EMERGENCY**



**SERVICING AND MAINTENANCE**



**TECHNICAL SPECIFICATIONS**



**MULTIMEDIA**



**INDEX**

ABC







# GETTING TO KNOW YOUR CAR

- INSTRUMENT PANEL . . . . . 8
- INSTRUMENT PANEL . . . . . 9
- THE KEYS . . . . . 10
- IGNITION DEVICE . . . . . 11
- ALFA ROMEO CODE SYSTEM. . . . . 12
- ALARM SYSTEM. . . . . 13
- DOORS. . . . . 13
- SEATS . . . . . 14
- HEADRESTS . . . . . 16
- STEERING WHEEL. . . . . 17
- REAR VIEW MIRRORS . . . . . 18
- EXTERNAL LIGHTS . . . . . 19
- INTERIOR LIGHTS . . . . . 21
- WINDSCREEN / REAR WINDOW WIPERS . . . . . 22
- CLIMATE CONTROL . . . . . 24
- ELECTRIC WINDOWS . . . . . 29
- ELECTRIC SUNROOF . . . . . 30
- ENGINE BONNET . . . . . 32
- BOOT. . . . . 33
- HEADLIGHTS. . . . . 34
- Alfa DNA SYSTEM (Car dynamic control system) . . . . . 34
- DYNAMIC SUSPENSION (active shock absorber system) . . . . . 35
- VERSION WITH LPG SYSTEM. . . . . 36

In-depth knowledge of your new car starts here.  
The booklet that you are reading simply and directly explains how  
it is made and how it works.  
That's why we advise you to read it seated comfortably on board,  
so that you can see what is described here for yourself.

## INSTRUMENT PANEL

### Left-hand drive versions

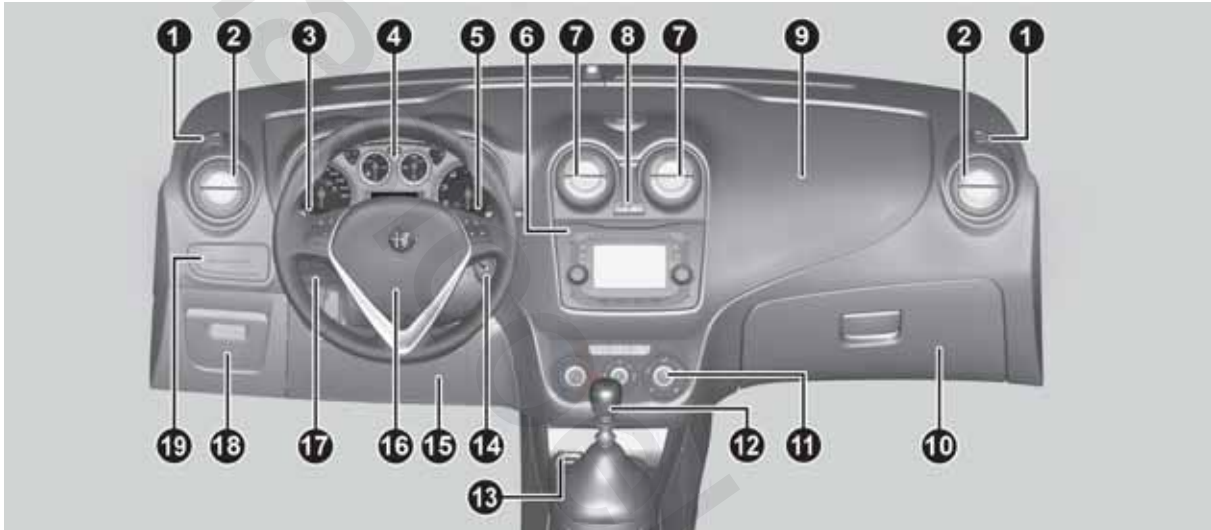

A0J0330C

1. Side windows air vents – 2. Adjustable and directable air diffuser – 3. Exterior light control lever – 4. Instrument panel – 5. Windscreen wiper/rear window wiper/trip computer control lever – 6. **Uconnect™** (where provided) – 7. Adjustable and directable air diffusers – 8. Hazard warning lights, door locking/unlocking button – 9. Passenger front airbag – 10. Glovebox – 11. HVAC controls – 12. Gear lever – 13. “Alfa DNA” system – 14. Ignition switch – 15. Driver side knee front airbag (where provided) – 16. Driver side front airbag – 17. Cruise Control lever (where provided) – 18. Fuse box access flap – 19. Panel with various controls.

## Right-hand drive versions

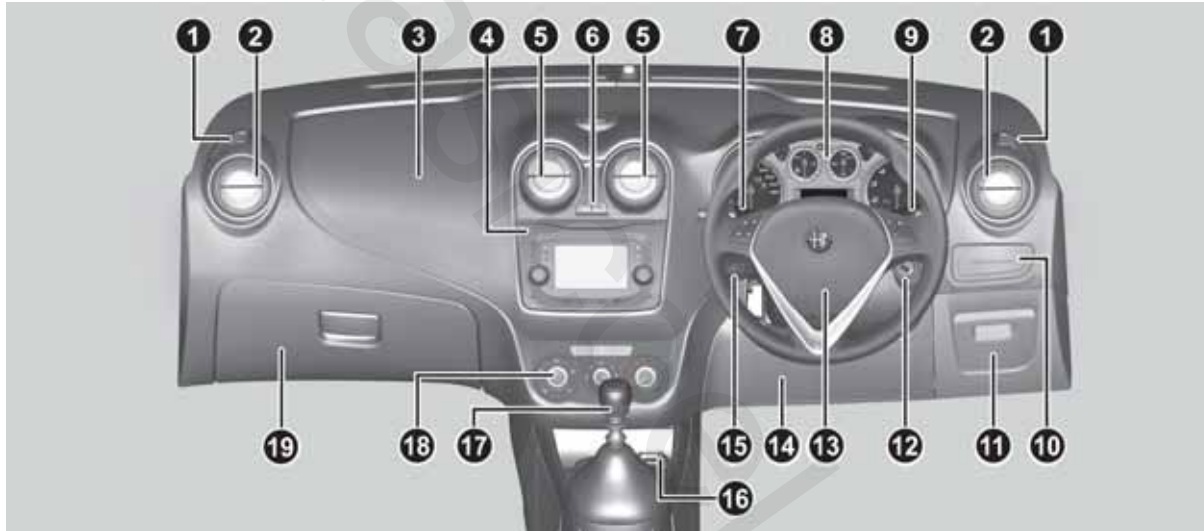

2

A0J0393C

1. Side windows air vents
2. Adjustable and directable air diffuser
3. Passenger front airbag
4. Uconnect(TM) (where provided)
5. Adjustable and directable air diffusers
6. Hazard warning lights, door locking/unlocking button
7. Exterior light control lever
8. Instrument panel
9. Windscreen wiper/rear window wiper/trip computer control lever
10. Panel with various controls
11. Fuse box access flap
12. Ignition switch
13. Driver side front airbag
14. Driver side knee front airbag (where provided)
15. Cruise Control lever (where provided)
16. "Alfa DNA" system
17. Gear lever
18. HVAC controls
19. Glove compartment



ABC

## THE KEYS

### MECHANICAL KEY

#### Operation

The metal insert 1 fig. 3 operates:

- the ignition switch;
- the door lock.



3

AOK0545C

### KEY WITH REMOTE CONTROL

(where provided)



1)

#### Operation

The metal insert 1 fig. 4 operates the ignition device and the door lock.

Press button 2 to open/close the metal insert.

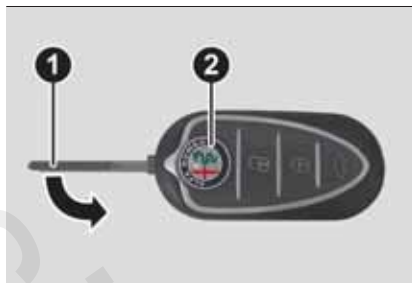

4

A0J0072C

#### Door and luggage compartment unlock:

briefly push  button to unlock doors and luggage compartment. This results in interior courtesy lights coming on with a timed delay and a double flash of the direction indicators (only for some versions).

#### Door and luggage compartment lock:

briefly push  button to lock doors and luggage compartment. This results in interior courtesy lights coming off and a single flash of the direction indicators (only for some versions).

#### Opening the luggage compartment:

press the  button to open the luggage compartment using the remote control. The direction indicators will flash twice to indicate that the luggage compartment has been opened.

## REQUESTING ADDITIONAL REMOTE CONTROLS



The system can recognise up to 8 keys with incorporated remote control. Should a new remote control be necessary, contact a Alfa Romeo Dealership and be ready to present the CODE Card (where provided), a personal identity document and the car's ownership documents.

## REPLACING THE BATTERY IN THE KEY WITH REMOTE CONTROL



1)

#### Procedure

- press button 1 fig. 5 and move the metal insert 2 to opening position; turn screw 4 to  using a fine bit screwdriver;
- remove battery compartment 5 and replace battery 3, respecting the polarity; reinsert compartment 5 in the key and secure it by turning screw 4 to .

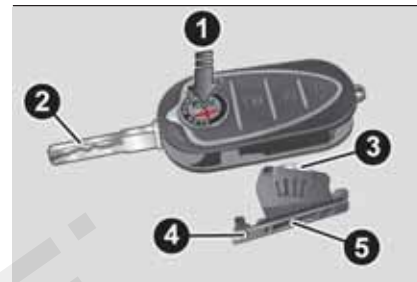

5



A0J0073C

## SAFE LOCK DEVICE

(where provided)

This safety device inhibits the operation of the interior door handles and the door locking/unlocking button. We recommend that you activate this device each time you park your car.

### Activating the device

The device is enabled on all the doors by pressing the button  on the key twice quickly. Device activation is indicated by 3 flashes of the direction indicators and a flash of the LED on the button  on the dashboard. The device does not come on if one or more doors is not properly shut.

### Deactivating the device

The device disengages automatically:

- the key insert is turned to opening position in the driver side door;
- by pressing the button  on the key;
- by turning the ignition key to the MAR position.

**IMPORTANT** Once the safe lock system is engaged, it is impossible to open the doors from inside the car. Therefore, before getting out of the car check that there is no one left on board. If the remote control battery is flat, the device can only be deactivated by using the metal insert in one of the door locks.



### WARNING

**1)** Press button 2 only with the key away from your body, especially your eyes and from objects which could get damaged (e.g. your clothes). Do not leave the key unattended to avoid the button being accidentally pressed while it is being handled, e.g. by a child.



### IMPORTANT

**1)** Used batteries may be harmful to the environment if not disposed of correctly. They must be disposed of as specified by law in the special containers or taken to an Alfa Romeo Dealership, which will take care of their disposal.

## IGNITION DEVICE

 2)3)

The key can be turned to three different positions fig. 6:

- STOP: engine off, key can be removed, steering column locked. Some electrical devices (e.g. central door locking system, alarm, etc.) are enabled;
- MAR: driving position. All electrical devices are enabled;
- AVV: engine starting.



6

A0J0031C

The ignition device is fitted with a safety system that requires the ignition key to be turned back to STOP if the engine does not start, before the starting operation can be repeated.

### STEERING LOCK

 4)5)

#### Activation

When the key is at STOP, remove the key



ABC

and turn the steering wheel until it locks.

### Deactivation

Move the steering wheel slightly and turn the ignition key to MAR.



#### WARNING

- 2)** If the ignition device has been tampered with (e.g. an attempted theft), have it checked over by the Alfa Romeo Dealership before driving again.
- 3)** Always remove the key when you leave your car to prevent someone from accidentally operating the controls. Remember to engage the handbrake. Engage first gear if the vehicle is parked uphill or reverse if the vehicle is parked downhill. Never leave children unattended in the vehicle.
- 4)** It is absolutely forbidden to carry out any after-market operation involving steering system or steering column modifications (e.g. installation of anti-theft device) that could adversely affect performance and safety, invalidate the warranty and also result in the car not meeting type-approval requirements.
- 5)** Never remove the key while the car is moving. The steering wheel will automatically lock as soon as it is turned. This holds true for cars being towed as well.

## ALFA ROMEO CODE SYSTEM



The Alfa Romeo Code prevents unauthorised use of the vehicle, disabling engine starting.

### Operation

Each time the car is started by turning the ignition key to MAR, the Alfa Romeo CODE system control unit sends an acknowledgement code to the Powertrain Control Module to deactivate the inhibitor.

The code is sent only if the Alfa Romeo CODE system control unit has recognised the code transmitted by the key.



Each time the ignition key is turned to STOP, the Alfa Romeo CODE system deactivates the functions of the Powertrain Control Module.

### Irregular operation

If, during starting, the code is not correctly recognised, the icon  appears on the instrument panel.

In this case, turn the key to STOP and then to MAR-ON; if it is still locked, try again with the other keys that come with the car. If it is still not possible to start the engine, contact an Alfa Romeo Dealership.

### Activation of warning light while driving

- If the icon  appears on the display, this means that the system is running a self-diagnosis (for example due to a voltage drop).
- If the icon  continues to be displayed, contact an Alfa Romeo Dealership.



#### IMPORTANT

- 1)** The electronic components inside the key may be damaged if the key is subjected to strong shocks. In order to ensure complete efficiency of the electronic devices inside the key, it should never be exposed to direct sunlight.

## ALARM SYSTEM

(where provided)

### ALARM ACTIVATION



Activation of the alarm triggers the acoustic warning and the direction indicators.

**IMPORTANT** The alarm is adapted by the Manufacturer to meet the requirements of the various countries where the vehicle is marketed.

### SWITCHING ON THE ALARM



With the doors, bonnet and tailgate closed and the ignition key either turned to STOP or removed, point the key with remote control towards the car and press and release the button .

Except on some versions for specific markets, the system produces a visual and acoustic warning and enables door locking.

### ALARM SELF-ACTIVATION

(where provided)

If the alarm has not been activated using the remote control, approximately 30 seconds after the key is turned to the STOP position and the last time one of the doors or tailgate was opened and reclosed, the alarm is activated automatically.

This condition is indicated by the intermittent illumination of the LED on the alarm deactivation button on the roof light and by the activation indications described previously.

To deactivate the alarm, press the button  on the remote control.

Alarm self-activation also occurs when the doors are closed by turning the metal insert of the key in the driver door lock. If the alarm is self-activated, the doors will not be locked.

### TURNING THE ALARM OFF

Press the  button. The following operations are performed (excluding some markets):

- two brief flashes of the direction indicators;
- there are two short acoustic signals;
- doors are unlocked.

**IMPORTANT** The alarm does not switch off when the central opening is activated using the metal insert in the key.

## DOORS

### DOOR CENTRAL LOCKING/UNLOCKING

#### Locking from the outside

With the doors closed, press the  button on the key or fit and then turn the metal insert (located inside the key) in the driver side door lock.

The door locking function is operated:  
 with all the doors closed;  
 with all the doors closed and boot open.

#### Door unlocking from the outside

Press the  button on the key or turn the metal insert (located inside the key) in the driver side door lock.

#### Door locking/unlocking from the inside

Press the 1 fig. 7 button on the dashboard. The button has an LED that indicates whether the doors are locked or unlocked. **LED on:** doors locked. **LED off:** doors unlocked.



ABC



7

AOJ0030C

In the absence of electrical power supply (e.g. blown fuse, battery disconnected, etc.) it is still possible to lock the doors manually.

**IMPORTANT** With the central locking system on, pull the door lever of one of the doors to open that door only (the LED on the button 1 will stay on if it is the passenger side door).

### PASSENGER SIDE FRONT DOOR EMERGENCY LOCKING DEVICE

The passenger side front door has a device to lock it when there is no electrical current. To lock it, fit the metal insert of the ignition key into housing 1 fig. 8 and move it upwards.

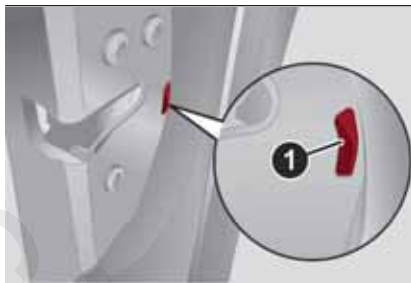





8

AOJ0309C

### Door opening/closing mechanism initialisation

If the battery is disconnected or the protection fuse blows, the door opening/closing mechanism must be initialised as follows:

- close all the doors;
- press the button  on the key or the button  on the dashboard;
- press the button  on the key or the button  on the dashboard.

## SEATS



### FRONT SEATS



#### Lengthwise adjustment

Lift lever 1 fig. 9 and push the seat forwards or backwards: in the driving position, you should be able to rest your arms on the rim of the steering wheel.



9

AOJ0078C



### Height adjustment

(where provided)

Move lever 2 up or down until the required height is reached.

**IMPORTANT** Carry out the adjustment whilst seated in the driver's seat.

### Backrest angle adjustment

Turn knob 3 until the required position is reached.

### Lumbar adjustment

(where provided)

Turn knob 4 until the required position is reached.

### Folding the seats

(where provided)

To access the rear seats, pull handle 5 upwards: the backrest will fold forwards and the seat will slide forwards when you push the backrest. Moving back the backrest will return the seat to its original position.

### Heated seats

(where provided)

With key at MAR, press button fig. 10 (one per seat) to activate/deactivate the function. When the function is enabled, the LED on the button turns on.



10

A0J0301C

### SPORT FRONT SEATS

(where provided)

#### Lengthwise adjustment

Lift lever 1 fig. 11 and push the seat forwards or backwards: in the driving position, you should be able to rest your arms on the rim of the steering wheel.

#### Backrest angle adjustment

Turn knob 2 until the required position is reached

#### Backrest tilt

To access the rear seats lift handle 3 upwards (behind the backrest). Then release the lever and pushing on the backrest, slide the seat forwards.

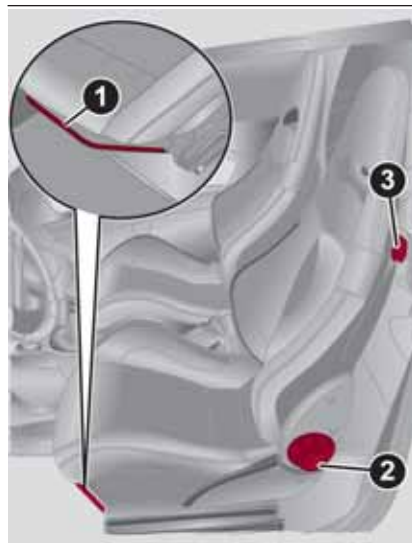

11

A0J0163C

### REAR SEAT

#### Seat folding

Proceed as follows:

- raise the headrests to the maximum height, press both buttons 1 fig. 12 to the side of the two supports, then remove the head restraints by sliding them upwards;
- move the seat belts to the side, making sure that they are correctly extended and not twisted;
- raise the backrest retaining levers 1 fig. 13 and fold ahead the desired cushion



ABC

(the lever 1 raising is highlighted with a “red band”).



12

AOJ0083C

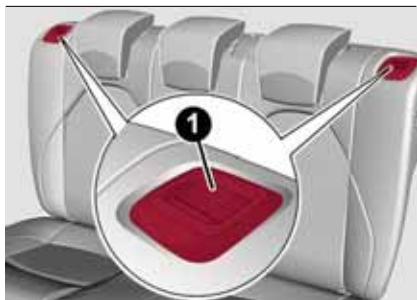

13

AOJ0082C

### Repositioning the rear seat

Move the seat belts to the side, making sure that they are correctly extended and not twisted.

Raise the previously folded backrest until you hear the click of the locking mechanism, visually checking that the

“red bands” on levers 1 fig. 13 are no longer visible. The “red band” indicates that the backrest is not secured.

Finally, reposition the head restraints, inserting them into their housings.



### WARNING

- 6)** All adjustments must be made with the car stationary.
- 7)** Once you have released the adjustment lever, always check that the seat is locked on the guides by trying to move it back and forth. If the seat is not locked into place, it may unexpectedly slide and cause the driver to lose control of the car.
- 8)** For maximum safety, keep the backrest upright, lean back into it and make sure the seat belt fits closely across your chest and pelvis.

## HEADRESTS



### FRONT

These are height-adjustable and lock into the desired position automatically.

To adjust the height, proceed as follows:

- upwards adjustment: raise the head restraint until it clicks into place;
- downward adjustment: press button 1 fig. 14 and lower the head restraint.

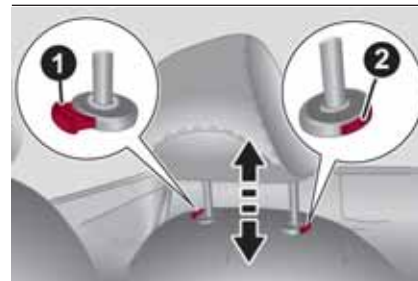

14

AOJ0130C

Proceed as follows to remove the head restraints:

- raise the head restraints to their maximum height;
- press buttons 1 and 2, then remove the head restraints by pulling them upwards.

## REAR

Two height-adjustable head restraints are provided for the back seats (for the adjustment see the previous paragraph).

On some versions a head restraint is also provided for the central seat.

Proceed as follows to remove the head restraints:

- raise the head restraints to their maximum height;
- press buttons 1 fig. 15 then remove the head restraints by pulling them upwards.



15

A0J0083C



### WARNING

**9)** Head restraints must be adjusted so that the head, rather than the neck, rests on them. Only in this case they can protect your head correctly.

## STEERING WHEEL



10)11)

It can be adjusted axially and vertically. To adjust, release the lever 1 fig. 16 by pushing it forwards (position A) and adjust the steering wheel. Having made the adjustment, lock lever 1 by pulling it towards the steering wheel (position B).

NOTE "Veloce" and "Sport" versions are equipped with sports configuration steering wheel.



16

A0J0034C



### WARNING

**10)** All adjustments must be carried out only with the car stationary and engine off.

**11)** It is absolutely forbidden to carry out any after-market operation involving steering system or steering column modifications (e.g. installation of anti-theft device) that could adversely affect performance and safety, invalidate the warranty and also result in the car not meeting type-approval requirements.



ABC

## REAR VIEW MIRRORS



### INTERIOR MIRROR

**Manual adjustment:** operate lever 1 fig. 17 to adjust the mirror between two positions: normal or anti-glare.



17

A0J0108C

### Electrochromic mirror

Some versions are equipped with an electro-chrome mirror with an ON/OFF switch to activate/deactivate the electro-chrome function. When reverse gear is engaged, the mirror is automatically set for daytime use.

### DOOR MIRRORS



12)

#### Electric adjustment

The mirrors can be adjusted/folded away only if the ignition key is in the MAR position.

Select the desired mirror using device 1 fig. 18:

- Position A: left mirror selected;
- Position C: right mirror selected.



18

A0J0022C

To adjust the selected mirror, press button 2 in the four directions shown by the arrows.

**IMPORTANT** Once adjustment is complete, rotate device 1 to position B to prevent accidental movements.

#### Electrical mirror folding (where present)

To fold the mirrors, press button 3. Press the button again to restore the mirrors to the driving position.

#### Manual mirror folding

When required, fold the mirrors in towards the vehicle.

**IMPORTANT** When driving, the mirrors must always be open.



### WARNING

**12)** As the driver's door mirror is curved, it may slightly alter the perception of distance.

## EXTERNAL LIGHTS



The left stalk fig. 19 operates most of the exterior lights. The external lights can only be switched on when the ignition key is at MAR.



19

A0J0063C

### DAYTIME RUNNING LIGHTS (DRL) "Daytime Running Lights"

With the ignition key at MAR and ring nut 1 turned to position, the daytime running lights switch on. The other lights and interior lighting stay off.

**IMPORTANT** The daytime running lights are an alternative to the dipped headlights for driving during the daytime in countries where it is compulsory to have lights on during the day; where it is not compulsory, the use of daytime running lights is permitted.

**IMPORTANT** Daytime running lights cannot replace dipped beam headlights when driving at night or through tunnels. The use of daytime running lights is governed by the Highway Code of the country in which you are driving. Comply with legal requirements.

### SIDE LIGHTS/DIPPED BEAM HEADLIGHTS

With the ignition key turned to MAR, turn the ring nut 1 to .

The daytime running lights are switched off and the side lights and dipped headlights are switched on. The warning light switches on in the instrument panel.

### PARKING LIGHTS

These lights can only be switched on with ignition key at STOP or removed, by moving ring nut 1 first to position and then to position.

With the parking lights, also the plate lights and front and rear direction lights (daytime running lights DRL remain switched off) switch on.

The warning light switches on in the instrument panel.

Operate the direction indicator stalk to select the light side (right or left)

### AUTOMATIC LIGHTING CONTROL (AUTOLIGHT) (Dusk sensor)

(where provided)

A sensor, located on the windscreen, detects the variations in outside brightness depending on the light sensitivity set with the Setup Menu: the greater the sensitivity, the less external light is required to activate the exterior lights.

#### Activation

Turn the ring 1 to the position to activate automatic control of the dipped beam headlights and taillights according to the external light conditions.

When the lights are automatically switched off, the front and rear fog lights (if activated) are also switched off. The next time the lights are switched on automatically, the fog lights must be reactivated manually (if required).

The headlights can only be flashed with the sensor on. To activate the dipped beam headlights, turn ring 1 to the position and then switch on the dipped beam headlights.

### MAIN BEAM HEADLIGHTS

To activate the main beam headlights, with ring nut 1 to , pull the stalk towards the steering wheel beyond the end of travel position. The warning light switches on in the instrument panel.



ABC

When the stalk is pulled towards the steering wheel again, beyond the end of travel position, the main beam headlights deactivate, the dipped headlights reactivate and the  warning light switches off.

It is not possible to switch on the main beam headlights constantly if automatic light control is active.



### FLASHING

To do this, pull the stalk towards the steering wheel (unstable position), regardless of the position of ring nut 1. The  warning light switches on in the instrument panel.

### HEADLIGHT ALIGNMENT CORRECTOR

This device works with the ignition key in the MAR position and the dipped headlights on.

#### Headlight alignment adjustment

Press buttons  and  fig. 20, to adjust. The adjustment position is shown on the display.

- Position 0: one or two people on the front seats.
- Position 1: 4 people.
- Position 2: 4 people + load in luggage compartment.
- Position 3: driver + maximum permitted load stowed in the luggage compartment.



20

A0J0306C



**NOTE** The button panel can change according to the versions.

**IMPORTANT** Check the alignment every time the load carried changes.

### FRONT FOG LIGHTS

(where provided)

#### Operation

Press the button  fig. 21 to switch the lights on/off. With the lights on, the warning light  in the instrument panel switches on.



21

A0J0303C

### REAR FOG LIGHT

#### Operation

Press the button  to switch the lights on/off.

The rear fog light switches on only when the dipped headlights are on.



Press the button again to switch the light off.

With the light on, the warning light  in the instrument panel switches on.

### DIRECTION INDICATORS

Bring the stalk to the (stable) position:

- upwards: activates right direction indicator;
- downwards: activates left direction indicator.

The  or  warning light will blink on the instrument panel.

The direction indicators are switched off automatically when the steering wheel is straightened.

### "Lane change" function

If you wish to signal a lane change, place the left stalk in the unstable position for less than half a second. The direction indicator on the selected side flashes three times and then switches off automatically.

### "FOLLOW ME HOME" DEVICE

This device allows you to illuminate the area in front of the car for a certain amount of time.

#### Activation

With the key turned to STOP or removed, pull the left-hand stalk 1 towards the steering wheel within 2 minutes from when the engine is turned off.

Each time the stalk is moved, the lights stay on for an extra 30 seconds up to a maximum of 210 seconds; then the lights are switched off automatically.

When the stalk is operated, the warning light  on the instrument panel switches on. The display shows a message and the time set for the function.

The warning light comes on when the stalk is operated and stays on until the function is automatically deactivated.

Each movement of the stalk only increases the amount of time the lights stay on.



#### Deactivation

Keep the stalk pulled towards the steering wheel for more than 2 seconds.

### EXTERNAL COURTESY LIGHTS

These light up the car and the space in front of it when the doors are unlocked.

#### Activation

When the car is parked and the doors are unlocked by pressing the  button on the remote control (or the luggage compartment is unlocked by pressing , the dipped beam headlights, rear side lights and number plate lights are activated.

The lights stay on for approximately 25 seconds unless the doors and luggage compartment are locked again with the remote control or the doors (or luggage compartment) are opened and reclosed. In these cases they switch off after 5 seconds.

## INTERIOR LIGHTS



### FRONT CEILING LIGHT

Switch 1 fig. 22 is used to switch on/off roof lights.

Switch 1 positions:

- central position (A position):* lights 3 and 4 switch on/off when the doors are opened/closed;
- pressed to the left (0 position):* lights 3 and 4 are always switched off;
- pressed to the right (B position):* lights 3 and 4 are always switched on.

Lights switch on/off progressively.



22

A0J0066C

Switch 2 fig. 22 operates the map reading light.

Switch 2 positions:

- central position (A position):* lights 3 and 4 are always switched off;



ABC

- pressed to the left (O position): light 3 switches on;
- pressed to the right (B position): light 4 switches on.

**IMPORTANT** Before getting out of the car, make sure that both switches are in the central position: when the doors are closed the lights will switch off to avoid draining the battery. In any case, if the switch is left in the on position, the roof light switches off automatically about 15 minutes after the engine has been switched off.

### ROOF LIGHT TIMING



#### Timing while getting into the car

The roof lights come on when unlocking, opening and closing. The timed period is interrupted when the ignition is turned to "MAR-ON".

#### Timing while getting out of the car

The roof lights come on when the key is removed from the ignition within 2 minutes of switching off the engine, on opening and closing a door with the removed key. The timing stops automatically when the doors are locked.

## WINDSCREEN / REAR WINDOW WIPERS



This operates only with the ignition key turned to MAR.

### WINDSCREEN WASHER / WIPER

#### Operation



13) 14)

Ring 2 fig. 23 can be set to the following positions:

0 – windscreen wiper off;

 – intermittent operation (low speed);

AUTO – rain sensor on (where provided);

 – intermittent operation;

 – continuous slow operation;

 – continuous fast operation.



23

A0J0064C

Move the stalk upwards (unstable

position) to limit operation to the time for which the stalk is held in this position. When released, the stalk will return to its default position and the windscreen wiper will be automatically stopped.

#### "Smart washing" function

Pull the stalk towards the steering wheel (unstable position) to operate the windscreen washer. Keep the stalk pulled for more than half a second to operate the windscreen washer jet and wiper automatically with a single movement.

The windscreen wiper stops working three strokes after the stalk is released. A further stroke after approx. 6 seconds completes the wiping cycle.

### RAIN SENSOR

(where provided)

It can detect the presence of rain and consequently manage windscreen wiping in accordance with the amount of water on the windscreen.

The sensor is activated when the ring 2 is turned to "automatic" position ("AUTO" control): the windscreen wiper stroke frequency is thus adjusted in accordance with the amount of water on the windscreen.

If no rain is detected, the wiper will not carry out any strokes.



## REAR WINDOW WIPER / WASHER

(where provided)

This operates only with the ignition key turned to MAR.

Turn ring 1 from **0** position to  position to operate the rear window wiper as follows:

- in intermittent mode when the windscreen wiper is not operating;
- in synchronous mode (at half the speed of the windscreen wiper) when the windscreen wiper is operating;
- in continuous mode with reverse gear engaged and the control active.

Pushing the stalk towards the dashboard (rocking position) will activate the rear window washer jet. Keep the stalk pushed for more than half a second to activate the rear window wiper as well. Releasing the stalk will activate the smart washing function, as described for the windscreen wiper.



### WARNING

**13)** *Never use the windscreen wipers to remove layers of snow or ice from the windscreen. In such conditions, the windscreen wiper may be subjected to excessive stress and the motor cut-out switch, which prevents operation for a few seconds, may intervene. If operation is not restored (even after restarting that car with the key), contact an Alfa Romeo Dealership.*

**14)** *Do not operate the windscreen wiper with the blades lifted from the windscreen.*



ABC

## CLIMATE CONTROL

### CLIMATE CONTROL / HEATING SYSTEM

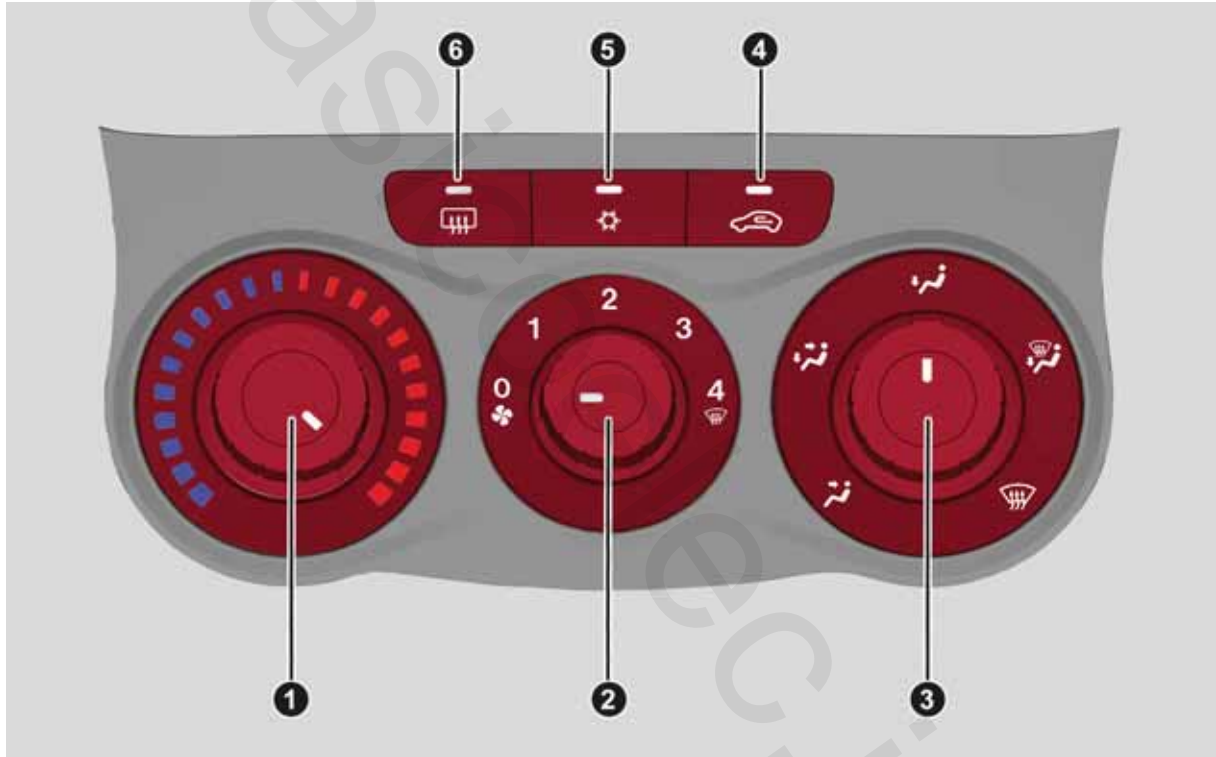

1 - air temperature adjustment knob: blue section = cold air / red section = hot air

2 - fan activation/adjustment knob: 0  = fan switched off / 1-2-3= fan speed / 4  = maximum fan speed

3 - air distribution knob

 air flow towards driver/passenger body

 air flow towards driver/passenger and feet area;

 air flow towards front and rear footwell;

 air flow towards feet area and windscreen;

 air flow towards windscreen

4 - air recirculation on/off button (It is advisable not to use the air recirculation function when the outside temperature is low to prevent the windows from rapidly misting up);

5 - climate control compressor on/off button;

6 - heated rear window on/off button.



ABC

## AUTOMATIC DUAL-ZONE CLIMATE CONTROL SYSTEM

(where provided)

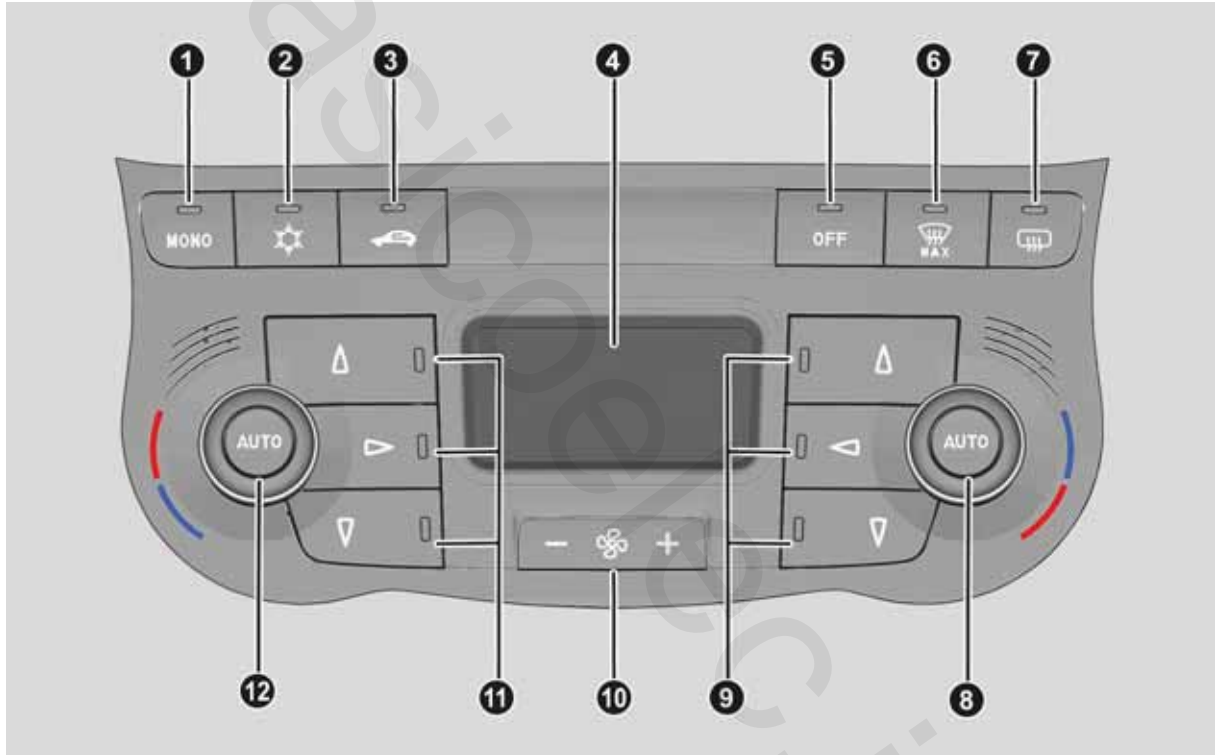

- 1 - MONO function button (set temperature alignment) driver/passenger side;
- 2 - climate control compressor on/off button;
- 3 - air recirculation on/off button (It is advisable not to use the air recirculation function when the outside temperature is low to prevent the windows from rapidly misting up);
- 4 - display;
- 5 - climate control system off button;
- 6 - button for activating the MAX-DEF function (fast front window defrosting/demisting);
- 7 - heated rear window on/off button;
- 8 - AUTO function activation button (automatic operation) and passenger side temperature adjustment knob;
- 9 - passenger side air distribution selection button;
- 10 - fan speed increase/decrease;
- 11 - driver's side air distribution selection button;
- 12 - AUTO function activation button (automatic operation) and driver side temperature adjustment knob;

#### **Air distribution selection**

- ▲ Air flow to the windscreen and front side window vents to demist/defrost them.
- ▶ Air flow at central and side dashboard vents to ventilate the chest and the face during the hot season.
- ▼ Air flow to the front and rear footwell vents. This air distribution setting heats the passenger compartment most quickly, giving a prompt sensation of warmth.

In FULL AUTO mode, the climate control system automatically manages air distribution (the LEDs on buttons 9 and 11 are off). When set manually, the air distribution is indicated by the LEDs on the selected buttons switching on

You can also set a combination of the air distribution settings described above. In combined function mode the relevant function is enabled simultaneously with those already set by pressing the corresponding button. If a button whose function is already active is pressed, the operation is cancelled and the corresponding LED switches off. To restore automatic control of the air distribution after a manual selection, press the AUTO button.



ABC

**CLIMATE CONTROL SYSTEM**

Climate control system adopts R-1234yf cooling gas with low environmental footprint (GWP < 150) according to “MAC Directive”.

Any refuelling must be done with specific oil, as indicated on the plate (in engine compartment) shown in fig. 26. For this operation, contact an Alfa Romeo Dealership.



26

AOJ0999C

## ELECTRIC WINDOWS



These operate when the ignition key is turned to MAR and for about 3 minutes after turning the key to STOP or removing it if one of the doors is open.

### Anti-crush safety device

An anti-crush device is operated when the windows are lifted. This safety system detects the presence of an obstacle during the window closing travel and cuts in by stopping and reversing the window travel, depending on its position. The anti-crushing feature is active during window manual and automatic operation.

### CONTROLS

#### Driver side door

- 1 fig. 27: front left window opening/closing
- 2: front right window opening/closing



27

A0J0023C

#### Window opening

Push the buttons to open the desired window. When one of the two buttons is pressed briefly, the window moves in "stages"; if the button is held down, "continuous automatic" operation is activated. If the button is pressed again, the window will stop in the desired position. If the button is held down for several seconds, the window raises or lowers automatically (only with ignition key in MAR position).

#### Window closing

Lift the buttons to close the desired window.

#### Passenger side door

The passenger side door is equipped with a button that controls the opening/closing of the passenger side window.

### Electric window system initialisation

The system must be re-initialised after disconnecting the battery or if the relevant protection fuse is blown. Perform the following initialisation procedure:

- fully close the window to initialise manually;
- after the window has reached the upper end of travel, hold the up button pressed for at least one second.

On some versions/markets, after there has been no power supply for the control units (battery replaced or disconnected or protection fuses for the electric window control units replaced), the automatic operation of the windows must be restored.

The restoration procedure must be performed as described below with the doors closed:

- completely open the driver's door window keeping the operating button pressed for at least three seconds after the (lower) end of travel position is reached;
- completely raise the driver side window and hold the button down for at least 3 seconds once the (upper) end of travel position has been reached;
- repeat stages 1 and 2 also for the passenger's window;



ABC

❑ make sure that the initialisation is correct by checking that the windows work automatically.



### IMPORTANT

**2)** The system conforms to the 2000/4/EC standard concerning the safety of passengers leaning out of the passenger compartment.



### WARNING

**15)** Incorrect use of the electric windows may be dangerous. Before and during their operation, ensure that any passengers are not at risk from the moving glass either by personal objects getting caught in the mechanism or by being hit by it directly. When leaving the car, always remove the key from the ignition to prevent accidental operation of the electric windows from being a hazard for those still on board.

## ELECTRIC SUNROOF

(where provided)



16)

3)

The extensively glazed sun roof comprises a moving glass panel and a sun blind.

When the glazed panel is closed it allows outside light to enter the passenger compartment and you can see out of it.

### OPERATION

The sun roof can be operated only with the ignition key turned to MAR. Controls 1 and 2, on the panel next to the front roof light control sun roof opening/closing.

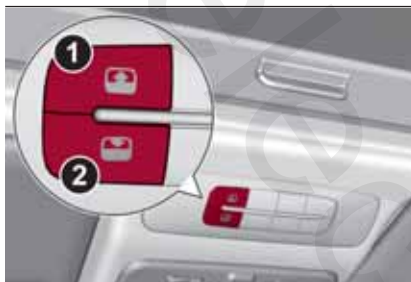

28

A0J0329C

### Open the sunroof

Press button 1.

**Prolonged button pressure:** “automatic” sunroof opening. From a completely closed position, the front glass panel will raise to the “spoiler” position. If the button is then pressed, the panel will start to slide backward until it is completely open. After the initial opening command, the glass panel can be stopped in intermediate positions by pressing the button again.

**Brief button pressure:** “manual” sunroof opening. The front glass panel moves from the completely closed position and stops in the position where the button is released. In this case the panel opens by pressing the actual button. This function makes it possible to place the front panel in intermediate positions in relation to those produced through automatic opening.

### Closing the sun roof

Press button 2.

**Prolonged button pressure:** “automatic” sunroof closing. With the roof completely open, holding down the button, the front glass panel will move to “spoiler” position. If the button is then pressed, the panel will start to slide forward until it is completely closed. After the initial opening command, the glass panel can be



stopped in intermediate positions by pressing the button again

**Brief button pressure:** “manual” sunroof closing. If button is pressed briefly, the front glass panel moves from the completely open position and stops in the position where the button is released. In this case, the panel closes by pressing it. This function makes it possible to place the front glass panel in intermediate positions in relation to those produced through automatic closing.

**IMPORTANT** The sun roof must stay closed if a transverse roof rack is fitted.

### ANTI-PINCH DEVICE

The sun roof has an anti-pinch safety system capable of detecting the presence of an obstacle whilst the roof is closing; when this happens, the system stops and the movement of the front glass is immediately reversed.

**IMPORTANT** The anti-pinch system is disabled through continuous pressure of button 2.

### INITIALISATION PROCEDURE

The sunroof must be re-initialised after disconnecting the battery or if the relevant protection fuse is blown.

Perform the following:

- press button 2 until the roof is completely closed. Then release the button;
- press button 2 and hold it down for at least 10 seconds and/or until the glass panel clicks forwards. Release the button at this point;
- within 5 seconds of the previous operation, press button B and hold it down: the front glass panel will complete a full opening and closing cycle. Only release the button at the end of this cycle.

### MAINTENANCE/EMERGENCY

In case of emergency or maintenance the roof can be moved manually when there is no power supply (opening/closing of the front glass panel) by carrying out the following operations:

- remove the protective cap 1 fig. 29 located on the internal lining, between the two sun blinds;
- take the Allen key 2 supplied (located in the on-board documentation container or in the toolbox in the luggage compartment);
- introduce the key into housing 3 and turn it clockwise to open the roof or anticlockwise to close the roof.

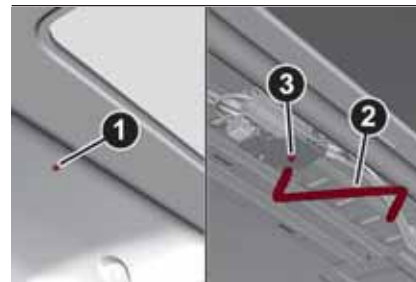

29

A0J0328C



### IMPORTANT

**3)** Do not open the sun roof if there is snow or ice on it: you may damage it.



### WARNING

**16)** When leaving the vehicle, always remove the key from the ignition switch to avoid the risk of injury to those still inside the car due to accidental operation of the sun roof. Improper use of the roof can be dangerous. Before and during operation, always check that no one is exposed to the risk of being injured by the moving sun roof or by objects getting caught or hit by it.



ABC

## ENGINE BONNET



17) 18) 19)

### OPENING

Proceed as follows:

- pull lever 1 fig. 30 in the direction indicated by the arrow;
- pull lever 2 in the direction indicated by the arrow;
- raise the bonnet and simultaneously release the support stay 3 from its blocking device, then insert the end in the housing 4, ensuring to trigger the stay in the smallest hole of retaining clip.

**IMPORTANT** Before raising the bonnet, make sure that the arms of the wipers are not raised from the windscreen and that the wiper is not operational.

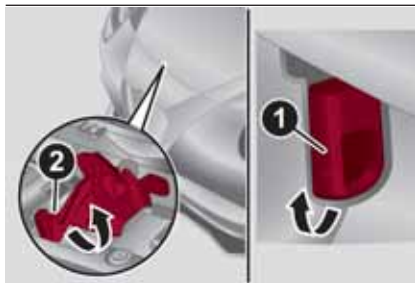

30

A0J0085C

### CLOSING

Proceed as follows:

- hold the bonnet up with one hand and with the other remove the stay 3 fig. 31 from the housing 4 and fit it back in its locking device;
- lower the bonnet to approximately 20 centimetres from the engine compartment and let it drop. Make sure that the bonnet is completely closed and not only fastened by the locking device by trying to open it. If it is not perfectly closed, do not try to press the bonnet down but open it and repeat the procedure.

**IMPORTANT** Always check that the bonnet is closed correctly to prevent it from opening while the vehicle is travelling.

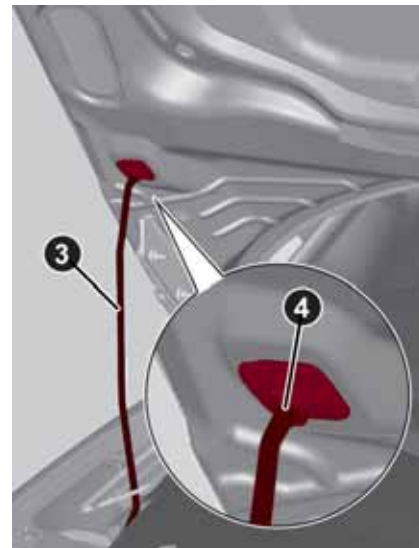

31

A0J0086C



### WARNING

**17)** For safety reasons, the bonnet must always be properly closed while the car is travelling. Therefore, make sure that the bonnet is properly closed and that the lock is engaged. If you discover that the bonnet is not perfectly closed during travel, stop immediately and close the bonnet in the correct manner.

**18)** Perform these operations only when the car is stationary.

**19)** The bonnet may drop suddenly if the supporting rod is not positioned correctly.

## BOOT



The luggage compartment unlocking is electrically operated and is deactivated when the car is in motion.

### OPENING

When unlocked, the luggage compartment can be opened from outside the car by pressing the electric logo fig. 32 until a click, which indicates unlocking, is heard or by pressing the  button on the key with remote control.

The direction indicators and internal light will blink twice when the boot is opened: the light will go out automatically when the boot is closed. The light switches off automatically after a few minutes if the luggage compartment is left open.



32

AOJ0058C

## Emergency opening from the inside

To carry out the emergency opening from the inside of the car, remove the rear seat head restraints, completely fold down the rear seats (see paragraph "Extending the luggage compartment"), then press on lever 1 fig. 33.



33

AOJ0178C

### CLOSING

Lower the tailgate, pressing near the lock until you hear it click into place.

On the tailgate inner part a tab makes the tailgate holding and closing easier.



**IMPORTANT** Before closing the luggage compartment make sure that you have the keys, since the luggage compartment is automatically locked.



ABC

## LUGGAGE COMPARTMENT INITIALISATION

**IMPORTANT** If the battery is disconnected or the protection fuse blows, the luggage compartment opening/closing mechanism must be initialised as follows:

- close all the doors and the luggage compartment;
- press the button  on the key;
- press the button  on the key;

## EXTENDING THE LUGGAGE COMPARTMENT

The luggage compartment can be partially (1/3 or 2/3) or totally extended by splitting the rear seat.

See the descriptions in "Rear seats" for how to expand the luggage compartment.

## HEADLIGHTS

### LIGHT BEAM DIRECTION

The correct orientation of the headlights is important for the driver's comfort and safety as well as for all other road users. This is also covered by a specific rule of the highway code.

The headlights must be correctly directed to ensure the best visibility conditions for all drivers. Contact a Alfa Romeo Dealership to have the headlights checked and adjusted, if necessary.

### FOG LIGHTS ALIGNMENT (where provided)

Contact a Alfa Romeo Dealership to have the headlights checked and adjusted, if necessary.

### ADJUSTING THE HEADLIGHTS ABROAD

The dipped beam headlights are aligned to comply with the regulations of the country of purchase. When driving in countries with a different traffic direction, to avoid blinding the drivers travelling in the opposite direction, it is necessary to cover the areas of the beam according to the provisions of the Highway Code of the country you are driving in.

## Alfa DNA SYSTEM (Car dynamic control system)



This device allows, using lever 1 fig. 34 (on the central tunnel), three car response modes to be selected according to driving style and road conditions:

- d = **Dynamic** (sports driving mode);
- n = **Natural** (mode for driving in normal conditions);
- a = **All Weather** (mode for driving in poor grip conditions, such as rain and snow).

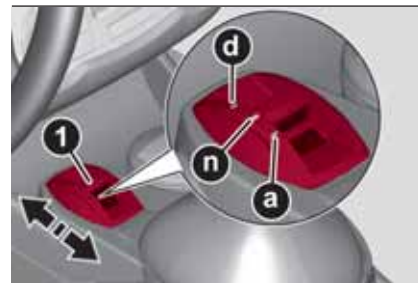

34

AOJ0090C

The lever 1 is of the monostable type. In other words, it always remains in a central position.

The selected driving mode is indicated by the corresponding LED switching on in the panel and by an indication on the display. When "Natural" mode is selected,

no messages or symbols are shown on the display.

The device also acts on the dynamic car control systems (engine, steering, ESC system, instrument panel).

### **TURNING "Dynamic" MODE ON/OFF**



#### **Activation**

Move lever 1 upwards (to the letter "d") and hold in this position for 0.5 seconds until the corresponding LED lights up or the word "Dynamic" appears on the display.

#### **Deactivation**

Mover the lever 1 to the "Natural" position.

#### **1.4 Turbo MultiAir versions**

Selecting the "Dynamic" operation mode, the turbocharger overboost feature is enabled. The engine management control unit allows - in relation to the position of the accelerator pedal and for a limited time - maximum pressure levels to be reached inside the turbocharger, with a consequent increase in engine torque with respect to that which is normally possible.

This function is particularly useful whenever maximum performance is required for a short time (e.g. when overtaking).

**IMPORTANT** During acceleration, when the "Dynamic" function is used the steering may shudder, which is typical of a sports setting.

### **TURNING "All Weather" MODE ON/OFF**

#### **Activation**

Move lever 1 downwards (to the letter "a") and hold in this position for 0.5 seconds until the corresponding LED lights up or the word "All Weather" appears on the display.

#### **Deactivation**

To deactivate "All Weather" mode (and return to "Natural"), carry out the same procedure described for "Dynamic" mode, but move lever 1 to "a".



#### **IMPORTANT**

**4) "FAST" VERSION:** *Considering the high levels of vehicle performance, it is recommended to not use the "Dynamic" mode when driving the first kilometres with the vehicle in order to provide the mechanical components with the necessary running-in period.*

### **DYNAMIC SUSPENSION (active shock absorber system)**

This system interacts with the "Alfa DNA" system. The "Alfa DNA" system lever allows you to choose three different driving settings depending on the route type and on the road surface (see paragraph "Alfa DNA system").

In "Natural" and "All Weather" operating mode, the active shock absorbers adjust the car suspension to suit the route type and the driving stresses, thus considerably improving driving comfort in particular on rough terrain.

The "Dynamic" operating mode produces a sports driving setting characterised by more responsive acceleration and greater effort on the steering wheel to give a sporty feeling. The shock absorber damping action is also adjusted and divided, to guarantee higher precision and reactivity of the car, while maintaining a good comfort level.

The driver will notice that the vehicle is more precise when cornering and quicker in changing direction.



ABC

## VERSION WITH LPG SYSTEM



⚠ 20) 22)

⚠ 5) 6) 7) 8) 9) 11)

### INTRODUCTION

The LPG version features two fuel supply systems: one for petrol and one for LPG.

### PASSIVE SAFETY / ACTIVE SAFETY

Although the LPG system has numerous safety features, it is advisable to proceed as follows every time the vehicle is not in use for a long period or moved in an emergency as a result of a breakdown or accident:

❑ unscrew the fixing devices 1 fig. 35, then remove the cover 2;



35

A0K0322C

❑ Close the LPG cock rotating the ring 1 fig. 36 clockwise.

❑ Refit the cover and retighten the fastening devices.



36

A0K0323C

### LPG TANK

The car has a pressurised tank for storing LPG in a liquid state. It is toroidal and is located in the spare wheel compartment with suitable protection.

### LPG tank certification

The LPG tank is certified in accordance with the regulations in force.

In Italy, the tank has a life of 10 years starting from the car registration date. If the vehicle has been registered in a country other than Italy, the duration and the testing/inspection procedures of the LPG tank can vary depending on the national provisions in force in that country. In any case, when the time limit in the individual country has run out, go to an Alfa Romeo Dealership to have the tank replaced.

## LPG/PETROL SWITCH

⚠ 21)

⚠ 10)

The fig. 37 petrol/LPG switch is located on the central tunnel and includes:

- ❑ 1 fig. 38: LPG/petrol switch;
- ❑ 2: LPG gauge consisting of five LEDs (4 green and 1 red to indicate the reserve). The orange LED turns on when only one green LED is on;
- ❑ 3: Petrol operating mode indicator: amber LED next to switch 1. This function is controlled directly by the LPG control unit;
- ❑ 4: LPG operating mode indicator: Green LED next to switch 1. This function is controlled directly by the LPG control unit.



37

A0J0314C

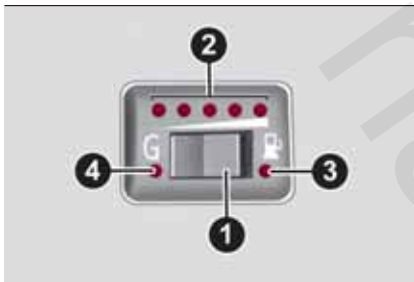



38

A0J0321C

**IMPORTANT** If the ignition key is turned to MAR, all the LEDs will stay on for approximately 4 seconds (check function).

**IMPORTANT** If the ignition key is turned to STOP, the LED for the operating mode selected will stay on for approximately 2 seconds (LED 3 or 4).

Engine starting always occurs on petrol; then, depending on the position of the switch 1 the following occurs:

- the switch pressed on the right side (identified by the symbol ): indicates petrol operation with activation of the associated orange LED 3;
- the switch pressed on the left side (identified by the symbol ): indicates LPG operation with activation of the associated green LED 4.

If the LPG runs out, the system automatically switches to petrol: the

orange LED 3 comes on and the green LED 4 indicating LPG operation goes off. When the vehicle is refuelled with LPG after a normal start-up on petrol, the fuel system automatically returns to LPG: the orange LED 3 switches off and the green LED 4 for LPG operation switches on.

## REFUELLING



12)

## LPG

Maximum refuelling capacity (including reserve): 39 litres. The figure already takes into account the 80% tank filling limit and the residual fluid required for priming; this figure represents the maximum permitted capacity. In addition, after different refuelling processes, this figure may vary due to differences between the network pump supply pressures, pumps having different supply/locking features, tank not completely run out of fuel.

**IMPORTANT** In order to avoid inconsistent information by the LPG gauge on the instrument panel, it is recommended to refill with at least 10 litres each time.



## WARNING

**20)** Note that in some countries (including Italy) there are legal restrictions in force for parking/garaging motor vehicles fuelled by gas that is denser than air; LPG comes under this category.

**21)** Do not switch between the two operating modes whilst starting the engine.

**22)** If gas is smelt, switch from LPG operation to petrol operation and immediately go to an Alfa Romeo Dealership to have the vehicle checked and possible system faults excluded.



## IMPORTANT

**5)** The car is equipped with a gaseous LPG injection system designed specifically for it: it is therefore absolutely forbidden to alter the configuration of the system or its components. The use of other components or materials could cause malfunctions and lead to a reduction in safety; therefore, in the case of problems, contact a Fiat Dealership. To prevent damage to the gas system parts when towing or raising the vehicle, follow the instructions in the "Towing the vehicle" paragraph of the Owner Handbook.

**6)** The system operates at temperatures ranging between  $-20^{\circ}\text{C}$  and  $100^{\circ}\text{C}$ .



ABC

**7)** When using a painting oven, the LPG tank should be removed from the car and later carefully refitted at an Alfa Romeo Dealership. Although the LPG system has numerous safety features, it is advisable to proceed as follows every time the vehicle is not in use for a long period or moved in an emergency as a result of a breakdown or accident: unscrew the devices fastening the cover of the LPG tank, then remove it. Close the LPG cock rotating the ring nut clockwise (see "Passive safety/ active safety"). Refit the cover and retighten the fastening devices.

**8)** When switching is requested, metallic noise from the valves which pressurise the circuit can be heard. For the switching logic described above, a delay between the valve ticking and the switching off of the instrument panel indication is completely normal.

**9)** It is strictly forbidden to use any additive in the LPG. Periodically (at least once every six months) it is advisable to let the LPG in the tank run out and, at the first refuelling, to check that it does not exceed the maximum capacity of 39 litres (with a tolerance of 2 litres excess). If the value is above 39 litres (with tolerance of 2 litres excess), contact an Alfa Romeo Dealership immediately.

**10)** In particular usage conditions, such as starting and operation at low ambient temperature or LPG supply with low propane content, the system may switch temporarily to petrol operation, without a visual indication on the petrol/LPG switch. In the event of low LPG levels in the tank or request for high performance (e.g. overtaking, car fully laden, steep hills) the system may automatically switch to petrol operation to guarantee the engine power requested. In this event, the performed switching is shown by the orange (petrol) LED lit and the green (LPG) LED off on the petrol/LPG switch. When the above conditions stop, the system automatically restores the LPG operation; the orange (petrol) LED turns off and the green (LPG) LED is lit on the switch. To achieve the automatic switching described above, make sure that there is always enough fuel in the petrol tank.

**11)** Only use LPG for motor vehicles.

**12)** The LPG supply system is equipped with a "consumption" function linked to the LED display of LPG level on the switch. This function activates only after a consistent variation in fuel level has been detected. It is therefore advisable to fill up with fuel at the first LPG refuelling to obtain a more "precise" indication of the level.





## KNOWING THE INSTRUMENT PANEL

CONTROL PANEL AND ON-BOARD INSTRUMENTS . . . . .	40
DISPLAY . . . . .	42
MENU ITEMS . . . . .	43
TRIP COMPUTER . . . . .	45
WARNING LIGHTS AND MESSAGES . . . . .	46
EOBD SYSTEM (European On Board Diagnosis) . . . . .	64

This section of the booklet gives you all the information you need to understand, interpret and use the instrument panel correctly.

## CONTROL PANEL AND ON-BOARD INSTRUMENTS

### RECONFIGURABLE MULTIFUNCTION DISPLAY



39

A011541C

1. Speedometer (speed indicator)
2. Reconfigurable multifunction display
3. Rev counter
4. Fuel level gauge with reserve warning light
5. Engine coolant temperature indicator with overheating warning light

⚠ Warning lights present on diesel versions only. On diesel versions, the end of scale for the rev counter is 6000 rpm

**IMPORTANT** The illumination of the instrument panel graphics may vary according to version.

## Version with instrument panel in MPH



40

A011542C

1. Speedometer (speed indicator)
  2. Reconfigurable multifunction display
  3. Rev counter
  4. Fuel level gauge with reserve warning light
  5. Engine coolant temperature indicator with overheating warning light
- ⚠️ Warning lights present on diesel versions only. On diesel versions, the end of scale for the rev counter is 6000 rpm

IMPORTANT The illumination of the instrument panel graphics may vary according to version.



ABC

## DISPLAY



The car is equipped with a reconfigurable multifunction display that, according to the previously applied settings, will show useful driving information.

With the ignition key removed, the display lights up and shows the time and total odometer reading (in km or miles) for a few seconds when a door is opened/closed.

### RECONFIGURABLE MULTIFUNCTION DISPLAY

The following information is shown on the display (example given in fig. 41):

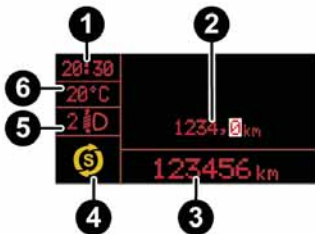

41

AOK0600C

- 1: Time
- 2: Area reserved for messages (information, settings, etc)
- 3: Mileometer (total distance covered in km or miles).

4: Car status indications (e.g. doors open, possible ice on road, etc.)/Start&Stop function indication (where provided)/Gear Shift Indicator (where provided)

5: Headlight alignment position (only with dipped beam headlights on)

6: External temperature

The turbocharger pressure will appear on some versions when “DYNAMIC” driving mode is selected (see “Alfa DNA system” in this chapter).

### GEAR SHIFT INDICATOR

(where provided)

The GSI (Gear Shift Indicator) system advises the driver to change gear through a special indication on the display.

Through the GSI, the driver is informed that the gear change will allow a reduction in fuel consumption.

Therefore, for driving oriented towards reducing fuel consumption, it is advisable to stick to “Natural” or “All Weather” mode and to follow the suggestions of the Gear Shift Indicator, where traffic conditions permit.

When the SHIFT UP icon ▲ is shown on the display the GSI suggests the driver to up-shift, whereas if the SHIFT DOWN icon ▼ is displayed, the driver is advised to down-shift.

The indication in the instrument panel remains on until the driver shifts gear or the driving conditions go back to a situation where gearshifting is not required to improve consumption.

### CONTROL BUTTONS

“+” or ▲ (versions with Start&Stop system) fig. 42: to scroll upwards through the screen and the related options or to increase the displayed value.

SET/ : press briefly to access the menu and/or go to next screen or confirm the selection. Hold down to go back to the standard screen.

“-” or ▼ (versions with Start&Stop system): to scroll downwards through the screen and the related options or to decrease the displayed value.







42

A0J0302C

**IMPORTANT** The control buttons activate different functions according to the following situations:

- within the menu, they allow you to scroll up or down;
- during settings operations, they increase or decrease values.

## SETUP MENU

The menu comprises a series of options which can be selected using the buttons   and   to access the different selection and setting (Setup) operations indicated below.

Some options have a submenu. The menu can be activated by briefly pressing the SET/button  .

The menu includes the following items:

- MENU
- LIGHTING
- SPEED WARNING
- HEADLIGHT SENSOR (where provided)
- RAIN SENSOR (where provided)
- TRIP B ACTIVATION
- SET TIME
- SET DATE
- FIRST PAGE (where provided)
- SEE RADIO
- AUTOCLOSE
- MEASUREMENT UNIT
- LANGUAGE
- WARNINGS VOLUME
- SEAT BELT BEEP
- SERVICE
- PASSENGER AIRBAG
- DAYTIME RUNNING LIGHTS

- COURTESY LIGHTS
- EXIT MENU

On vehicles equipped with **Uconnect™** system (where provided), some menu items are shown on the navigator display.

## MENU ITEMS



**IMPORTANT** If there is an **Uconnect™** system, some menu items are displayed and managed by the latter and not the instrument panel (refer to the description in the “Multimedia” chapter or in the supplements available online).

### Menu

Access to the Setup Menu.

### Lighting

(only with side lights on)

Adjustment (8 levels) of the brightness of the instrument panel, the **Uconnect™** system controls (where provided) and the dual-zone automatic climate control system controls (where provided).

### Speed warning

Vehicle speed limit setting (km/h or mph). When this is exceeded, the driver is notified by an audible warning signal.

### Headlight sensor

(where provided)

Automatic switch on/off of lights according to external light conditions.

The dusk sensor sensitivity can be adjusted according to 3 levels (level 1=minimum sensitivity, level 2=average sensitivity, level 3=maximum sensitivity).



ABC

**Rain sensor**

(where provided)

Adjustment (4 levels) of the sensitivity of the rain sensor.

**TripB activation**

Activation ("On") and deactivation ("Off") of Trip B display (partial trip counter). For more information see the "Trip computer" section.

**Set time**

Clock setting through two sub-menus: "Time" and "Format".

**Set date**

Date setting (day - month - year).

**First page**

(where provided)

Selection of the information you would like to see on the main screen. You can view the date or the trip distance.

**See radio**

On the instrument panel display, the information on **Uconnect™** system is shown.

**Autoclose**

Activation of the automatic locking of the doors on exceeding the speed of 20 km/h.

**Measurement unit**

Unit of measurement setting via three submenus: "Distances", "Fuel

consumption" and "Temperature". If the set distance unit is "km", the display allows the fuel consumption unit to be set as km/l or l/100km. If the set distance unit is "mi" the fuel consumption unit will be displayed in "mpg".

**Language**

Display language selection.

**Warning volume**

Adjustment (8 levels) of the volume of the buzzer which accompanies the display of failures/warnings.

**Seat belt beep**

This function can be displayed only after an Alfa Romeo Dealership has deactivated the SBR system (see paragraph "SBR system" in the "Safety" chapter).

**Service**

Display of information about km/mileage intervals or, for versions/markets, where provided, time intervals for car servicing.

**Passenger airbag**

Activation/deactivation of front passenger side airbag and side air bag for pelvis, chest and shoulder protection - Side bag

**Daytime running lights**

Activation/deactivation of Daytime Running Lights (DRL).

**Courtesy lights**

This function turns on the internal courtesy lights for approximately 25 seconds when the doors or luggage compartment are opened using the remote control. The courtesy lights are turned off when the doors are closed or locked using the remote control.

**Exit Menu**

Return to standard display screen.

## TRIP COMPUTER

The Trip computer is used to display information on car operation when the key is turned to MAR. This function is characterised by two separate records, called "Trip A" and "Trip B", where the car's "complete missions" (journeys) are recorded in a reciprocally independent manner. Both memories can be reset: i.e. start of a new journey.

"Trip A" can be used to display the values relating to:

- Range
- Distance travelled A
- Average consumption A
- Instant consumption
- Average speed A
- Trip time (driving time) A

"Trip B" may be used to display the figures relating to:

- Distance travelled B
- Average consumption B
- Average speed B
- Trip time B (driving time).

The "Trip B" function may be disabled (see "Activating Trip B"). "Range" and "Instant consumption" values cannot be reset.



ABC

## WARNING LIGHTS AND MESSAGES



**IMPORTANT** The warning light switches on in the instrument panel together with a dedicated message and/or acoustic signal when applicable. These indications are indicative and precautionary and as such must not be considered as exhaustive and/or alternative to the information contained in the Owner Handbook, which you are advised to read carefully in all cases. Always refer to the information in this section in the event of a failure indication.

**IMPORTANT** Failure indications displayed are divided into two categories: very serious and less serious failures. Serious faults are indicated by a repeated and prolonged warning "cycle". Less serious faults are indicated by a warning "cycle" with a shorter duration. The display cycle of both categories can be interrupted. The instrument panel warning light will stay on until the cause of the malfunction is eliminated.

### WARNING LIGHTS ON INSTRUMENT PANEL

Warning lights on panel	What it means	What to do
	<p><b>LOW BRAKE FLUID/HANDBRAKE ENGAGED</b> The warning light switches on when the key is turned to MAR-ON, but it should switch off after a few seconds.</p>	
	<p><b>Low brake fluid level</b> The warning light (or symbol on the display) switches on when the level of the brake fluid in the reservoir falls below the minimum level, possibly due to leaks in the circuit.</p>	<p>Restore the brake fluid level, then check that the warning light has switched off. If the warning light stays on, contact an Alfa Romeo Dealership.</p>
	<p><b>Handbrake engaged</b> The warning light (or symbol on the display) switches on when the handbrake is engaged. If the car is moving an acoustic signal is also emitted.</p>	<p>Release the handbrake, then check that the warning light has switched off. If the warning light (or symbol on the display) stays on, contact an Alfa Romeo Dealership.</p>







Warning lights on panel	What it means	What to do
	<p><b>EBD FAILURE</b></p> <p>The simultaneous switching on of the (⚠) (red) and (ABS) (amber) warning lights with the engine on indicates either an anomaly of the EBD system or that the system is not available. In this case, the rear wheels may suddenly lock and the vehicle may swerve when braking sharply.</p>	<p>Drive very carefully to the nearest Alfa Romeo Dealership to have the system inspected immediately.</p>
	<p><b>AIRBAG FAILURE</b></p> <p>The warning light switches on when the ignition key is turned to MAR, but it should switch off after a few seconds. If the warning light switches on constantly, this indicates a fault in the airbag system. The display shows the dedicated message</p>	<p> 23) 24)</p>





ABC





Warning lights on panel	What it means	What to do
	<p><b>ENGINE COOLANT TEMPERATURE TOO HIGH</b> The warning light switches on when the ignition key is turned to MAR, but it should switch off after a few seconds. The warning light turns on when the engine is overheated. The display shows the dedicated message.</p>	<p><i>In normal driving conditions:</i> stop the car, switch off the engine and check that the water level in the reservoir is not below the MIN mark. In this case, wait for the engine to cool down, then slowly and carefully open the cap, top up with coolant and check that the level is between the MIN and MAX marks on the reservoir itself. Also check visually for any fluid leaks. Should the warning light turn on again at the next start-up, contact an Alfa Romeo Dealership.</p> <p><i>If the vehicle is used under demanding conditions:</i> (e.g. in high-performance driving): slow down and, if the warning light stays on, stop the vehicle. Wait for 2 or 3 minutes with the engine running and slightly accelerated to further favour the coolant circulation. Then stop the engine. Check that the coolant level is correct as described above.</p> <p><b>IMPORTANT</b> Over demanding routes, it is advisable to keep the engine on and slightly accelerated for a few minutes before switching it off.</p>

Warning lights on panel	What it means	What to do
	<p>ALFA TCT FAILURE (where provided)</p> <p>The warning light switches on when the ignition key is turned to MAR, but it should switch off after a few seconds.</p> <p>The warning light begins to flash (on some versions, the symbol and a message appear on the display) to indicate a gearbox fault.</p> <p>On the display, together with the warning light, the following messages can be shown:</p> <ul style="list-style-type: none"> <li><input type="checkbox"/> "Check transmission" message;</li> <li><input type="checkbox"/> "Gear not available" message;</li> <li><input type="checkbox"/> "Manual mode not available" message;</li> <li><input type="checkbox"/> "Automatic mode not available" message;</li> <li><input type="checkbox"/> "Required manoeuvre incompatibility" message;</li> <li><input type="checkbox"/> "Clutch overheating" message.</li> </ul>	<p>Contact an Alfa Romeo Dealership as soon as possible. If it is necessary to start the engine with a transmission failure, follow the procedure described in the "Alfa TCT" paragraph, in chapter "Starting and driving".</p>
	<p><b>Clutch overheating</b></p> <p>The  warning light (or the symbol the display) switches on (together with a message) to indicate clutch overheating.</p>	<p>In this case limit the gear changes and/or change the condition of use, until normal operating conditions are restored. If the driver continues, the  warning light (or symbol on the display) will switch off and the  warning light (or symbol on the display) will switch on, together with a message on the display, to indicate an automatic transmission fault. In this case, stop immediately, operate the handbrake, and wait for 5 minutes: after this, transmission operation conditions will be restored. If the fault persists, contact an Alfa Romeo Dealership as soon as possible.</p>







ABC





Warning lights on panel	What it means	What to do
	<p>LOW ENGINE OIL PRESSURE</p> <p>When the key is turned to MAR the warning light comes on, but should go out as soon as the engine is started.</p> <p>After turning the ignition key to MAR, wait for about 2 seconds before starting the engine.</p> <p>The warning light switches on constantly together with a message on the display (where provided) when the system detects that engine oil pressure is low.</p> <p><b>IMPORTANT</b> Do not use the vehicle until the failure has been solved.</p> <p><b>IMPORTANT</b> To find out the correct oil quantity, always check using the dipstick.</p>	 13)
	<p>DEGRADED ENGINE OIL (where provided)</p> <p>The warning light will turn on flashing and, on some versions, with a specific message on the display.</p> <p>Depending on the versions, the warning light flashing modes are as follows:</p> <ul style="list-style-type: none"> <li>- for 1 minute every two hours;</li> <li>- for 3 minute cycles with the warning light off for intervals of 5 seconds until oil is changed.</li> </ul> <p>After the initial warning, each time the engine is started up, the warning light will continue to flash in the same mode, until the oil is changed. On some versions, the display shows a dedicated message together with the warning light. If the warning light flashes, this does not mean that there is a fault, but simply informs that it is now necessary to change the oil as a result of regular use of the car. Engine oil deterioration is accelerated by:</p> <ul style="list-style-type: none"> <li>- mainly town use of the car which makes the DPF regeneration process more frequent;</li> <li>- use of the vehicle for short drives, in which the engine does not have time to reach its regular operating temperature;</li> <li>- repeated interruptions of the regeneration process, signalled by the DPF warning light switching on.</li> </ul>	<p>Contact an Alfa Romeo Dealership as soon as possible.</p>  25)

Warning lights on panel	What it means	What to do
	<p><b>FUEL RESERVE/LIMITED RANGE</b>            The warning light turns on when about 5 - 7 litres of fuel are left in the tank.            When the remaining range is lower than approx. 50 km (or equivalent value in miles), on some versions the display will show a warning message.</p>	 26)
	<p><b>REAR FOG LIGHT</b>            The warning light switches on when the rear fog light is switched on.</p>	
	<p><b>ABS FAILURE</b>            The warning light switches on when the ignition key is turned to MAR, but it should switch off after a few seconds.            The warning light switches on to indicate a system fault. In this case the braking system maintains its efficiency unaltered but without the advantage of the ABS system. The display shows the dedicated message.</p>	<p>Drive carefully and contact an Alfa Romeo Dealership as soon as possible.</p>
	<p><b>START&amp;STOP SYSTEM DEACTIVATION</b>            The warning light switches on when the Start&amp;Stop system is deactivated (for more information, see the paragraph "Start&amp;Stop System" in the chapter "Starting and driving").            On some versions the display shows the dedicated message.</p>	



ABC

Warning lights on panel	What it means	What to do
	<p><b>INJECTION/EOBD SYSTEM FAILURE</b>            In normal conditions, when the ignition key is turned to MAR the warning light switches on, but it should switch off as soon as the engine is started. The operation of the  warning light may be checked by the traffic police using specific devices. Comply with the laws and regulations of the country where you are driving.</p>	 14)
	<p>If the warning light remains on or switches on whilst driving, it means that the injection system is not working properly. The warning light on constantly signals a malfunction in the supply/ignition system which could cause high exhaust emissions, a possible loss of performance, poor driveability and high consumption.            The warning light goes out after the fault disappears: the indication is stored in the system.</p>	<p>Under these conditions, the vehicle can continue travelling at moderate speed without demanding excessive effort from the engine. Prolonged use of the car with the warning light on constantly may cause damage.            Contact an Alfa Romeo Dealership as soon as possible.</p>
	<p><b>GLOW PLUG HEATING/GLOW PLUG HEATING FAILURE</b> (diesel versions)            This warning light switches on when the key is turned to MAR. It will switch off as soon as the heater plugs have reached a preset temperature. The engine can be started as soon as the warning light switches off.  <b>WARNING</b> In mild or high temperature conditions, the warning light comes on for a very short time only.</p>	
	<p><b>Glow plug preheating failure</b>            The warning light will flash to indicate a failure in the glow plug preheating system.</p>	<p>Contact an Alfa Romeo Dealership as soon as possible.</p>



Warning lights on panel	What it means	What to do
	<p><b>WATER IN DIESEL FILTER</b> (Diesel versions) The warning light switches on constantly when driving to indicate the presence of water in the diesel filter.</p>	 15)
	<p><b>DPF CLEANING</b> (particulate trap) in progress (diesel versions with DPF only) The warning light switches on when the ignition key is turned to MAR, but it should switch off after a few seconds. The warning light switches on constantly to indicate that the DPF system needs to eliminate the trapped pollutants (particulate) through the regeneration process. The warning light does not come on during every DPF regeneration, but only when driving conditions require that the driver is notified. To turn off the warning light, keep the car in motion until the regeneration process is over. On average, the process lasts 15 minutes. Optimal conditions for completing the process are achieved by travelling at 60 km/h with engine speed above 2000 rpm. When this warning light switches on, it does not indicate a vehicle failure and thus it should not be taken to a workshop.</p>	 27)



ABC





Warning lights on panel	What it means	What to do
	<p><b>TPMS SYSTEM</b>  <b>Low tyre pressure</b>                      The warning light (or symbol on the display) switches on (on some versions together with a message on the display) (together with an acoustic signal) if the pressure in one or more tyres drops below a preset threshold.                      In this way the TPMS warns the driver that one or more tyres may be dangerously flat and liable to puncture.</p>	<p>In any situation in which the message on the display is "See manual", it is <b>ESSENTIAL</b> to refer to the contents of the "Wheels" paragraph in the "Technical specifications" section, strictly complying with the indications that you find there.  <b>IMPORTANT</b> Do not continue driving with one or more flat tyres as handling may be compromised. Stop the vehicle, avoiding sharp braking and steering. Replace the wheel immediately with the spare wheel (where provided) or carry out a prompt repair using the dedicated kit (see the paragraph on "Replacing a wheel" in chapter "In an emergency") and contact Alfa Romeo Dealership as soon as possible.</p>
	<p><b>TPMS failure</b>                      This warning light switches on (on some versions together with a message on the display) when a TPMS fault is detected. Should one or more wheels be fitted without sensors, the display will show a warning message until initial conditions are restored.</p>	<p>Contact an Alfa Romeo Dealership as soon as possible.</p>
	<p><b>Check tyre pressure</b>                      The warning light switches on (on some versions together with a message in the display) to indicate that the tyre pressure is below the value recommended to guarantee long tyre life and low fuel consumption. It may also indicate a slow loss of pressure. Should two or more tyres be in the condition mentioned above, the display will show the indications corresponding to each tyre in sequence. In this case it is advisable to restore the correct pressure value</p>	





Warning lights on panel	What it means	What to do
	<p><b>ELECTRONIC STABILITY CONTROL (ESC) SYSTEM</b>            When the ignition key is turned to MAR, the warning light switches on, but should switch off as soon as the engine is started.            If the warning light does not switch off (on some versions together with a message on the display) or if it stays on with the engine running, this indicates a fault in the ESC system.            Intervention by the system is indicated by the flashing of the warning light: it indicates that the car is in critical stability and grip conditions.</p>	<p>In case of a fault, contact an Alfa Romeo Dealership as soon as possible to have the problem diagnosed and resolved.</p>
	<p><b>ASR system failure</b>            When the ignition key is turned to MAR, the warning light switches on, but should switch off as soon as the engine is started. If the warning light does not switch off (on some versions together with a message on the display) or if it stays on with the engine running, this indicates a fault in the ASR system.            The warning light will flash while driving to indicate that the ASR system is intervening.</p>	<p>In case of a fault, contact an Alfa Romeo Dealership as soon as possible.</p>
	<p><b>Hill Holder failure</b>            If the warning light turns on (together with the display of the symbol  and a message) indicates a fault to Hill Holder system.</p>	<p>In case of a fault, contact an Alfa Romeo Dealership as soon as possible.</p>



ABC

Warning lights on panel	What it means	What to do
	<p><b>CRUISE CONTROL</b> (where provided)</p> <p>This warning light switches on when the ignition key is turned to MAR, but it should switch off after a few seconds, if the Cruise Control is deactivated. The warning light switches on when the Cruise Control ring is turned to the ON position (see the "Cruise Control" paragraph in the "Knowing your vehicle" section). The display shows the dedicated message.</p>	
	<p><b>SIDE LIGHTS</b></p> <p>The warning light switches on when the side lights are activated.</p> <hr/> <p><b>FOLLOW ME HOME</b></p> <p>The warning light switches on (together with a message shown on the display) when this device is in use (see the "Exterior lights" paragraph in the "Knowing your vehicle" section).</p>	
	<p><b>DIPPED HEADLIGHTS</b></p> <p>The warning light switches on when the dipped beam headlights are turned on.</p>	
	<p><b>FRONT FOG LIGHTS</b></p> <p>The warning light comes on when the front fog lights are turned on.</p>	
	<p><b>LEFT DIRECTION INDICATOR</b></p> <p>The warning light switches on when the direction indicator control lever is moved downwards or, together with the right direction indicator, when the hazard warning light button is pressed.</p>	







Warning lights on panel	What it means	What to do
	<p><b>RIGHT DIRECTION INDICATOR</b> The warning light turns on when the direction indicator control lever is moved upwards or, together with the left direction indicator, when the hazard warning light button is pressed.</p>	







Warning lights on panel	What it means	What to do
	<p><b>MAIN BEAM HEADLIGHTS</b> The warning light switches on when the main beam headlights are turned on.</p>	



ABC





## SYMBOLS ON THE DISPLAY

Symbol on the display	What it means	What to do
	<b>ALTERNATOR FAILURE</b> The symbol appears on the display in case of alternator failure.	If the symbol continues to be displayed, contact an Alfa Romeo Dealership immediately.
	<b>ELECTRIC POWER STEERING FAILURE</b> (where provided) The symbol appears on display in case of electric Power Steering failure. If the symbol is still displayed (together with a message) you will not benefit from the electric power steering and the effort needed to turn the wheel will be significantly increased, although it will still be possible to steer the car.	If the symbol continues to be displayed, contact an Alfa Romeo Dealership immediately.
	<b>DOOR OPEN</b> (where provided) The symbol appears on the display when one or more doors are not completely shut. An acoustic signal is activated with the doors open and the car moving.	Close the door(s) properly.
	<b>LUGGAGE COMPARTMENT OPEN</b> The symbol appears on the display (together with a message) when the luggage compartment is open	Close the boot correctly.
	<b>BONNET OPEN</b> The symbol appears on the display (together with a message) when the bonnet is open	Close the bonnet properly.
	<b>SPEED LIMIT EXCEEDED</b> (where provided) The symbol appears on the display when the vehicle speed exceeds 120 km/h. An acoustic signal is also emitted.	Contact an Alfa Romeo Dealership as soon as possible.

Symbol on the display	What it means	What to do
	<b>FUEL CUT-OFF SYSTEM</b> The display will show the symbol if the fuel cut-off system intervenes.	For the procedure to restore the fuel cut-off system see the "Controls" paragraph in the "Knowing your vehicle" section. If it is still not possible to restore the fuel supply, contact an Alfa Romeo Dealership.
	<b>EXTERIOR LIGHTS FAILURE</b> The symbol appears on the display when there is a fault in one of the following lights: <input type="checkbox"/> daytime running lights (DRL) <input type="checkbox"/> side lights <input type="checkbox"/> direction indicators <input type="checkbox"/> rear fog light <input type="checkbox"/> number plate lights The fault relating to these lights may be caused by: one or more blown fuses, one or more blown bulbs or a broken electrical connection.	Check, and if necessary replace the fuses involved, in accordance with the "Fuse replacement" paragraph, in chapter "In an emergency". If this does not resolve the fault, check, and if necessary replace, the bulbs involved, in accordance with the "External bulb replacement" paragraph, in chapter "In an emergency". Should this operation also fail to resolve the fault, contact an Alfa Romeo Dealership, for a comprehensive check of the electrical system.
	<b>BRAKE LIGHT FAILURE</b> The display will show the symbol if a fault in the brake lights is detected.	The fault may be caused by a blown bulb, a blown protection fuse or an interruption of the electrical connection.
	<b>DUSK SENSOR FAILURE</b> (where provided) The symbol appears on the display (together with a message) in the event of dusk sensor failure.	Go to an Alfa Romeo Dealership to have the fault fixed as soon as possible.
	<b>RAIN SENSOR FAILURE</b> (where provided) The symbol appears on the display (together with a message) in the event of rain sensor failure.	Go to an Alfa Romeo Dealership to have the fault fixed as soon as possible.
	<b>PARKING SENSOR FAILURE</b> (where provided) The symbol appears on the display (together with a message) in the event of parking sensor failure.	Go to an Alfa Romeo Dealership to have the fault fixed as soon as possible.



ABC

Symbol on the display	What it means	What to do
	<p>ALFA ROMEO CODE SYSTEM FAILURE/ALARM FAILURE (where provided) The symbol appears on the display to indicate a fault with the Alfa Romeo CODE system or alarm system (where provided).</p>	<p>Go to an Alfa Romeo Dealership to have the fault fixed as soon as possible.</p>
	<p>BREAK IN ATTEMPT If the symbol appears on the display (together with a message) this indicates a break-in attempt.</p>	<p>Contact an Alfa Romeo Dealership as soon as possible.</p>
	<p>GENERAL FAILURE (where provided) The symbol appears on the display in the circumstances indicated below:</p> <ul style="list-style-type: none"> <li><input type="checkbox"/> overheating of the Alfa TCT gearbox (where provided);</li> <li><input type="checkbox"/> fuel cut-off;</li> <li><input type="checkbox"/> engine oil pressure sensor fault.</li> </ul>	<p>In these cases contact an Alfa Romeo Dealership to have the fault fixed as soon as possible.</p>
	<p>BRAKE PAD WEAR (where provided) The symbol appears on the display when the front or rear brake pads are worn.</p>	<p>Have them replaced as soon as possible.</p>
	<p>START&amp;STOP SYSTEM FAILURE The symbol appears on display in case of Start&amp;Stop system failure. On some versions, a warning message will be displayed.</p>	<p>Contact an Alfa Romeo Dealership as soon as possible.</p>
	<p>POSSIBLE ICE ON ROAD A symbol is displayed when the outside temperature falls to or below 3°C. WARNING In the event of an outdoor temperature sensor fault, dashes are shown on the display instead of a temperature value.</p>	

Symbol on the display	What it means	What to do
	<p>DYNAMIC SUSPENSION FAILURE (active shock absorber system) (where provided)</p> <p>The symbol appears on the display in case of active shock absorber system failure.</p>	<p>Contact an Alfa Romeo Dealership as soon as possible.</p>



ABC

**MESSAGES ON THE DISPLAY****Display of selected Driving Mode ("Alfa DNA" system)**

(where provided)

A message and a symbol relating to the use of the driving mode selected are shown: "DYNAMIC", "NATURAL" OR "ALL WEATHER".

A warning message is shown on the display if one of these driving modes is not available.

**Engine oil level display**

(where provided)

When the ignition key is turned to MAR the display shows, for a few seconds, the engine oil level.

In case of insufficient engine oil level, a warning message appears on the display.

**IMPORTANT** To find out the correct oil quantity, always check using the dipstick (see paragraph "Checking levels" in the section "Maintenance and care"). For a correct engine oil level indication, perform the check with the car parked on a level surface.





**IMPORTANT** To perform the engine oil reading correctly, after turning the key to MAR, wait for about 2 seconds before starting the engine.

**IMPORTANT** The engine oil level may increase after a long stop.







## WARNING

- 23)** If the  warning light does not switch on when the ignition device is moved to ON or if it stays on when driving (together with the message on the display), there might be a fault in the restraint systems; in this case, the airbags or pretensioners may not deploy in the event of an accident or, in a lower number of cases, they could deploy erroneously. Before proceeding, contact an Alfa Romeo Dealership to have the system checked immediately.
- 24)** A fault with the warning light  is signalled by illumination of the icon  on the instrument panel display and by the flashing of passenger airbag disabled warning light on the rearview mirror. In addition, the airbag system automatically disables the passenger side airbag (where provided). In this case, the warning light may not indicate any faults with the restraint systems. Before proceeding, contact an Alfa Romeo Dealership to have the system checked immediately.
- 25)** If the warning light comes on, the exhausted engine oil should be changed as soon as possible, never drive more than 500 km from the first switching-on of this warning light. Failure to observe the above may result in severe damage to the engine and invalidate the warranty. Remember that when this warning light comes on, it does not mean that the level of engine oil is low, so if it flashes you must not top up the engine oil.
- 26)** If the warning light flashes with the car in motion, contact an Alfa Romeo Dealership.
- 27)** Always drive at a speed appropriate to the traffic conditions, the weather and traffic regulations. The engine may be switched off even if the  warning light is on: repeated interruptions of the regeneration process could cause an early deterioration of engine oil. For this reason it is always advisable to wait for the symbol to go off before turning off the engine, following the instructions above. Do not complete the DPF regeneration process when the vehicle is stopped.



## IMPORTANT

- 13)** If the  warning light switches on when driving, stop the engine immediately and contact an Alfa Romeo Dealership.
- 14)** If, turning the ignition device to MAR, the warning light  does not turn on or if it turns on steadily or flashing when travelling (on some versions together with the message on the display), contact an Alfa Romeo Dealership as soon as possible.
- 15)** The presence of water in the fuel system circuit may cause severe damage to the injection system and irregular engine operation. If the  symbol is displayed contact an Alfa Romeo Dealership as soon as possible to bleed the system. If the above indications come on immediately after refuelling, water has probably been introduced into the tank: stop the engine immediately and contact an Alfa Romeo Dealership.



ABC

## **EOBD SYSTEM (European On Board Diagnosis)**

(where provided)

### **Operation**

The EOBD system (European On Board Diagnosis) carries out a continuous diagnosis of the components of the car related to emissions.

It also alerts the driver, by switching on the warning light  on the instrument panel, together with a message on the display, when these components are no longer in peak condition (see "Warning lights and messages" paragraph in the "Knowing the instrument panel" chapter).

The aim of the EOBD system (European On Board Diagnosis) is to:

- monitor the efficiency of the system;
- indicate an increase in emissions;
- indicate the need to replace damaged components.

The vehicle also has a connector, which can interface with appropriate tools, that makes it possible to read the error codes stored in the electronic control units together with a series of specific parameters for engine operation and diagnosis. This check can also be carried out by the traffic police.

**IMPORTANT** After eliminating a fault, to check the system completely, the Alfa Romeo Dealership is obliged to run tests and, if necessary, road tests which may also require a long journey.



## SAFETY

ACTIVE SAFETY SYSTEMS . . . . .	66
TPMS (Tyre Pressure Monitoring System). . . . .	68
SEAT BELTS . . . . .	70
SBR SYSTEM (Seat Belt Reminder) . . . . .	72
PRE-TENSIONERS. . . . .	73
CARRYING CHILDREN SAFELY . . . . .	75
FITTING "UNIVERSAL" CHILD RESTRAINT SYSTEM (with seat belts). . . . .	76
ISOFIX CHILD RESTRAINT SYSTEM SETUP . . . . .	79
FRONT AIRBAGS. . . . .	81
SIDE AIRBAGS (SIDE BAG - WINDOW BAG). . . . .	86

The chapter that you are about to read is very important: it describes the safety systems with which the car is equipped and provides instructions on how to use them correctly.

## ACTIVE SAFETY SYSTEMS

### ABS SYSTEM



33) 34) 35) 36) 37) 38) 39)

This system, which is an integral part of the braking system, prevents one or more wheels from locking and slipping in all road surface conditions, irrespective of the intensity of the braking action, ensuring that the vehicle can be controlled even during emergency braking and optimising stopping distances.

#### System intervention

The driver can feel that the ABS system has come into action because the brake pedal pulsates slightly and the system gets noisier: this is entirely normal with the system operating.

### ASR (AntiSlip Regulation) SYSTEM



40) 41) 42)

This is an integral part of the ESC system and automatically operates in the event of one or both drive wheels slipping, loss of grip on wet roads (aquaplaning) and acceleration on slippery, snowy or icy roads, etc.

### System intervention

The system operates on the engine power and brakes.

This is indicated by the flashing of the warning light on the instrument panel, to inform the driver that the car is in critical stability and grip conditions.

### BRAKE ASSIST SYSTEM (assistance during emergency braking)

The system, which cannot be turned off, recognises emergency braking (on the basis of the brake pedal operating speed) and speeding up the response of the braking system. The Brake Assist device is deactivated if there is a ESC system failure.

### MSR (Motor Schleppmoment Regelung) SYSTEM

The system prevents the drive wheels from possibly locking, which could happen, for example, if the accelerator pedal is released suddenly or in the case of a sudden downshifting in conditions of poor grip.

In this conditions, the engine braking effect could cause the drive wheels to slip, resulting in a loss of vehicle stability. In these situations, the system intervenes, restoring torque to the engine in order to conserve vehicle stability and increase vehicle safety.

### DST SYSTEM (Dynamic Steering Torque)



46)

This function integrates Dual Pinion active steering into the operation of ESC. For particular manoeuvres, the ESC system controls the steering to actuate a steering torque and assist the driver in the best possible way.

The system operates the brakes and steering in a coordinated manner to increase the suspension and safety level of the car as a whole. The steering provides additional torque on the steering wheel.

### EBD SYSTEM

The EBD system is an integral part of the ESC system and intervenes during braking, distributing the brake force optimally between front and rear wheels. This guarantees greater braking stability for the car, preventing sudden locking of the rear wheels and the consequent instability of the car.

### ESC SYSTEM



28) 29) 30) 31) 32)

The ESC system improves the directional control and stability of the car in various driving conditions.

The ESC system corrects the car's understeer and oversteer, distributing the brake force on the appropriate wheels. The torque supplied by the engine can also be reduced in order to maintain control of the vehicle.

The ESC system comprises the active safety systems such as: ABS, EBD, ASR, HILL HOLDER, BRAKE ASSIST, MSR, CBC, "ELECTRONIC Q2", DST.

The ESC system switches on automatically when the engine is started and cannot be switched off.

### System intervention

This is indicated by the flashing of the warning light  on the instrument panel, to inform the driver that the car is in critical stability and grip conditions.

### CBC (Cornering Brake Control) SYSTEM

This system acts when braking on corners, optimising the distribution of brake pressure on the four wheels: the system prevents the wheels on the inside of the corner (less affected by the weight of the car) from locking, ensuring better stability and direction for the car.

### HILL HOLDER SYSTEM



This is an integral part of the ESC system and facilitates starting on uphill or downhill slopes by operating the brakes:

**IMPORTANT** The Hill Holder system is not a parking brake; therefore, never leave the car without having engaged the handbrake, turned the engine off and engaged first gear, so that it is parked in safe conditions (for further information read the "Parking" paragraph in the "Starting and driving" chapter).

**IMPORTANT** There may be situations on small gradients (less than 5%), with car laden, in which the Hill Holder system may not activate, causing a slight reversing motion and increasing the risk of collision with another vehicle or object. The driver is, in any case, responsible for safe driving.

### "ELECTRONIC Q2" SYSTEM ("E-Q2")

The "Electronic Q2" system intervenes during acceleration on corners, braking the inner drive wheel and thus increasing the traction of the outer wheel (which bears more of the car's weight): the torque is thus distributed optimally between the drive wheels in accordance with the driving conditions and road surface, permitting particularly effective, sporty driving.



### WARNING

**28)** The ESC system cannot alter the natural laws of physics, and cannot increase grip, which depends on the condition of the road.

**29)** The ESC system cannot prevent accidents, including those due to excessive speed on corners, driving on low-grip surfaces or aquaplaning.

**30)** The capability of the ESC system must never be tested irresponsibly and dangerously, in such a way as to compromise personal safety and the safety of others.

**31)** For the correct operation of the ASR system, the tyres must of necessity be the same make and type on all wheels, in perfect condition and, above all, of the prescribed type and dimensions.

**32)** Do not take unnecessary risks, even if your vehicle is fitted with the ESC and ASR systems. Your driving style must always be suited to the road conditions, visibility and traffic. The driver is always responsible for road safety.

**33)** When the ABS intervenes and you feel the brake pedal pulsating, do not reduce the pressure, but hold it down firmly and confidently; in doing so you will brake in the shortest distance possible, depending on the current road conditions.

**34)** To obtain the maximum efficiency of the braking system, a bedding-in period of about 500 km is needed: during this period it is better to avoid sharp, repeated and prolonged braking.

**35)** If the ABS intervenes, this indicates that the grip of the tyres on the road is nearing its limit: you must slow down to a speed compatible with the available grip.



ABC

**36)** The ABS cannot overrule the natural laws of physics, and cannot increase the grip available according to the condition of the road.

**37)** The ABS cannot prevent accidents, including those due to excessive speed on corners, driving on low-grip surfaces or aquaplaning.

**38)** The capability of the ABS must never be tested irresponsibly and dangerously, in such a way as to compromise personal safety and the safety of others.

**39)** For the correct operation of the ABS, the tyres must of necessity be the same make and type on all wheels, in perfect condition and, above all, of the prescribed type and dimensions.

**40)** The ASR cannot overrule the natural laws of physics, and cannot increase the grip available according to the condition of the road.

**41)** The ASR system cannot prevent accidents, including those due to excessive speed on corners, driving on low-grip surfaces or aquaplaning.

**42)** The capability of the ASR must never be tested irresponsibly and dangerously, in such a way as to compromise personal safety and the safety of others.

**43)** The HBA system can't overrule the natural laws of physics, and can't increase the grip available according to the condition of the road.

**44)** The HBA system cannot prevent accidents, including those due to excessive speed on corners, driving on low-grip surfaces or aquaplaning.

**45)** The features of the HBA system must never be tested in imprudent or dangerous ways, with the possibility of putting the safety of the driver, occupants or other road users at risk.

**46)** DST is an aid for driving and does not relieve the driver of responsibility for driving the vehicle.

## TPMS (Tyre Pressure Monitoring System)

(where provided)

 47) 48) 49) 50) 51) 52) 53) 54) 55)

### DESCRIPTION

The vehicle can be equipped with the tyre pressure monitoring system T.P.M.S. which informs the driver about the tyre inflating condition through viewing on the display specific warning messages.

This system comprises a radio frequency transmitter fitted to each wheel (on the wheel rim inside the tyre), which is able to send information on the tyre inflation pressure of each wheel to the control unit.

### IMPORTANT NOTES ABOUT THE TPMS

The fault indications are not stored and will therefore not be displayed after the engine has been switched off and then on again.

If the fault conditions persist, the control unit will send the relative indications to the instrument panel only after the car has been in motion for a short time.

In order to use the system properly, refer to the following table when you have to change wheels/tyres:

Operation	Sensor	Failure indication	Alfa Romeo Dealership intervention
-	-	YES	Contact an Alfa Romeo Dealership
Wheel change with space-saver wheel	NO	YES	Repair damaged wheel
Wheel change with winter tyres	NO	YES	Contact an Alfa Romeo Dealership
Wheel change with winter tyres	YES	NO	-
Wheel change with others of a different size (*)	YES	NO	-
Switching wheels (front/rear) (**)	YES	NO	-

(\*) Given as an alternative in the Owner Handbook and available from Lineaccessori Alfa Romeo.

(\*\*) Not cross-swapped (tyres must stay on the same side).



ABC

**WARNING**

- 47)** The presence of the TPMS does not permit the driver to neglect regular checks of the tyre pressure, including for the spare wheel.
- 48)** Tyre pressure must be checked with tyres cold. Should it become necessary for whatever reason to check pressure with warm tyres, do not reduce pressure even though it is higher than the prescribed value, but repeat the check when tyres are cold.
- 49)** Should one or more wheels be fitted without sensors, the system will no longer be available and, in addition to the TPMS warning light flashing for less than one minute before becoming constant, a warning message will be shown on the display, until 4 wheels with sensors are fitted again.
- 50)** The TPMS cannot warn of sudden decreases in tyre pressure (for example when a tyre bursts). In this case, stop the car, braking with caution and avoiding abrupt steering.
- 51)** Replacing standard tyres with winter tyres (and vice versa) requires TPMS adjustment that must only be performed by a dedicated Alfa Romeo Dealership.
- 52)** Changes in outside temperature may cause tyre pressures to vary. The TPMS system may temporarily indicate insufficient pressure. In this case, check the tyre pressure when cold and, if necessary, restore the inflation values.

- 53)** When a tyre is removed, it is advisable to replace the rubber valve seal as well: contact a dedicated Alfa Romeo Dealership. Tyre and/or rim fitting/removal operations require specific precautions; to avoid damaging or fitting the sensors incorrectly, tyre and/or rim fitting/removal operations should only be carried out by specialised staff. Contact a dedicated Alfa Romeo Dealership.
- 54)** Intense radio-frequency interference may prevent the correct operation of the TPMS. This condition will be indicated by a message on the display. The message will disappear automatically as soon as the radio-frequency interference ceases to affect the system.
- 55)** The tyre repair kit (Fix&Go) provided with the vehicle (for versions/markets, where provided) is compatible with the TPMS sensors; using sealants not equivalent with that in the original kit may adversely affect its operation. If sealants not equivalent with the original one are used, it is recommended to have the TPMS sensors checked by a qualified repair centre.

**SEAT BELTS****USING THE SEAT BELTS**

56) 57) 58)

All vehicle seats are equipped with seat belts with three anchor points and a retractor.

The retractor mechanism operates locking the belt in the event of sharp braking or strong deceleration due to an impact. This allows the belt strap to slide freely and to adapt to the body of the occupant. In the event of an accident, the belt will lock reducing the risk of impact inside the passenger compartment and of being projected outside the vehicle.

The driver is responsible for respecting, and ensuring that all the other occupants of the vehicle also respect, the local laws in force in relation to the use of the seat belts.

Always fasten the seat belts before setting off.

**Using the seat belts**

The belt should be worn keeping the torso straight and rested against the backrest.

To fasten the safety belts, hold the tongue 1 fig. 43 and insert it into the buckle 2, until it clicks into place. If the seat belt jams during removal, let it rewind for a short stretch, then pull it out again without jerking.



Press button 3 to release the belt. Guide the safety belt while it is rewinding to prevent it from twisting. Through the retractor, the safety belt automatically adapts to the body of the passenger wearing it, allowing freedom of movement.



43

A0J0101C

The retractor may lock when the vehicle is parked on a steep slope: this is perfectly normal. Furthermore, the reel mechanism locks the belt if it is pulled sharply or in the event of sudden braking, collisions and high-speed bends.

The rear seat is fitted with inertia seat belts with three anchor points and a retractor.

Wear the rear safety belts according to the illustration fig. 44.

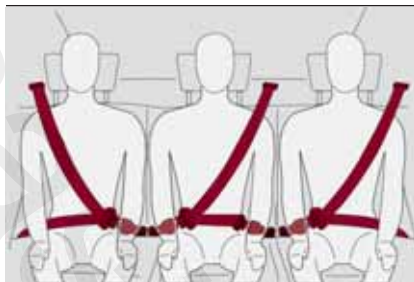

44

A0K0921C

**IMPORTANT IMPORTANT** The backrest is correctly secured when the red band 2 fig. 45 on the backrest folding handles 1 disappears. This red band indicates that the backrest is not secured.

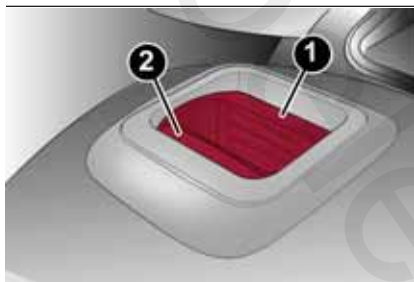

45

A0J0182C

**IMPORTANT** When putting the rear seats back to their normal position, make sure the seat belts are positioned so they are ready to use.



## WARNING

- 56)** Never press button 2 fig. 43 when travelling.
- 57)** Remember that, in the event of an accident, the rear seat passengers not wearing seat belts are exposed to a very serious risk and also represent a serious danger for the front seat occupants.
- 58)** Make sure that the backrest is correctly secured on both sides (red bands not visible) to prevent it from moving forward in the event of sharp braking, causing injuries to occupants.



ABC

## SBR SYSTEM (Seat Belt Reminder)

It consists of an acoustic warning which, switching on the  warning lights in the trim located on the fig. 46 internal rear view mirror, warns passengers in the front and rear seats that their seat belts are not fastened.

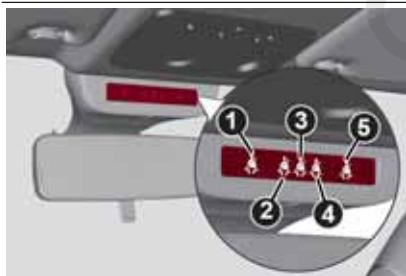

46

A0J0108C

For long-term deactivation of the SBR system, contact a Alfa Romeo Dealership.

The SBR system can be reactivated at any time through the Setup Menu only (see "Menu Items" in "Knowing your vehicle" section).

The warning lights may be red or green and operate as follows:

- 1 = front left seat (driver status for left-hand drive versions)
- 2 = rear left seat (passenger);
- 3 = rear centre seat (passenger)

- 4 = rear right seat (passenger);
- 5 = front right seat (passenger status for left-hand drive versions).

NOTE On versions equipped with sport front seats, the indication of passenger side seat belt fastened (warning light 1 for right-hand drive versions or warning light 5 for left-hand drive versions) will never be displayed.

### FRONT SEATS (warning light 1 = driver and 5 = passenger)

#### Driver

If the driver is the only occupant and the seat belt is not fastened, when 20 km/h is exceeded or when travelling at a speed from 10 to 20 km/h for longer than 5 seconds, a buzzer sequence will be started (front seats) consisting of a tone for 6 seconds followed by a 90 second beep. The warning light will blink.

The warning lights will stay on constantly at the end of the cycle until the engine is stopped. The acoustic signal will be interrupted immediately when the driver's seat belt is fastened and the warning light will turn green.

The reminder cycle (acoustic and visual) will be repeated as described above and the red warning light will flash if the seat belt is unfastened again while travelling.

### Passenger

A similar solution applies for the front passenger, with the difference that the warning light turns green and the signal is interrupted also when the passenger leaves the car.

It both front seat belts are unfastened while the vehicle is travelling a few seconds apart, the acoustic indication will refer to the most recent event and the two warning lights will proceed with the visual indication independently.

### REAR SEATS (warning light 2, 3 and 4)

The reminder cycle is run only when any seat belt is unfastened (red blinking).

In this condition, the warning light for the seat belt which has been unfastened will start flashing red for approximately 30 seconds. An acoustic signal is also emitted.

The visual indication (blinking red) will start and end independently for each warning light if several seat belts are unfastened. The warning light will become green when the relevant seat belt is fastened again.

After about 30 seconds from the last indication, the warning lights for rear seats will switch off, irrespective of the belt conditions (red or green).

## IMPORTANT NOTES

- ❑ All warning lights will remain off if all the seat belts (front and rear) are already fastened when the key is turned to MAR.
- ❑ All the warning lights will come on when at least one belt changes from fastened to unfastened status or vice versa.

## PRE-TENSIONERS



The vehicle is equipped with front seat belt pretensioners, which draw back the seat belts by several centimetres in the event of a strong frontal impact. This guarantees the perfect adherence of the seat belts to the occupant's bodies before the retention action begins.

It is evident that the pretensioners have operated when the belt withdraws toward the retractor.

This car is also equipped with a second pretensioner (fitted in the kick plate area). Its activation is signalled by the shortening of the metal cable.

A slight discharge of smoke may be produced during the activation of the pretensioner which is not harmful and does not involve any fire hazard.

**IMPORTANT** To obtain the highest degree of protection from the action of the pretensioner, wear the seat belt tight to the torso and pelvis.

The pretensioner does not require any maintenance or lubrication: any changes to its original conditions will invalidate its efficiency. If, due to unusual natural events (floods, sea storms, etc.), the device has been affected by water and/or mud, contact an Alfa Romeo Dealership to have it replaced.

## LOAD LIMITERS

To increase passenger safety, the front seat belt reels contain a load limiter which allows the force acting on the chest and shoulders to be modulated during the belt restraining action in the event of a frontal impact.

## GENERAL INSTRUCTIONS FOR USING THE SEAT BELTS



Seat belts must also be worn by pregnant women: the risk of injury in the event of an accident is reduced for them and the unborn child if they are wearing a seat belt.

Pregnant women must position the lower part of the belt very low down so that it passes over the pelvis and under the abdomen fig. 47.



47

A0K0250C

The belt must not be twisted. The upper part must pass over the shoulder and



ABC

cross the chest diagonally. The lower part must adhere to the pelvis. Each seat belt must be used by only one person. Never travel with a child sitting on the passenger's lap and a single belt to protect them both (fig. 49). In general, do not place any objects between the person and the belt.



49

AOK0013C

## SEAT BELTS MAINTENANCE



16)

- always use the seat belt with the strap well stretched and not twisted; make sure that it is free to run without obstructions;
- replace the belt after an accident of a certain severity even if it does not appear to be damaged. Always replace the seat belt if the pretensioners were deployed;
- check seat belt operation as follows: attach the seat belt and pull it hard;

- prevent the retractors from getting wet: their correct operation is only guaranteed if water does not get inside;
- replace the seat belt when it shows wear or cuts.



## WARNING

- 59)** The pretensioner may be used only once. After its activation, contact an Alfa Romeo Dealership to have it replaced.
- 60)** Removing or tampering with seat belt and pretensioner components is strictly prohibited. Any intervention on these components must be performed by qualified and authorised technicians. Always contact a dedicated Alfa Romeo Dealership.
- 61)** For maximum safety, keep the backrest upright, lean back into it and make sure the seat belt fits closely across your chest and pelvis. Always fasten the seat belts for both the front and rear seats! Travelling without wearing seat belts will increase the risk of serious injury and even death in the event of an accident.
- 62)** If the belt has been subjected to high levels of stress, for example after an accident, it should be changed completely together with the attachments, attachment fixing screws and the pretensioner. In fact, even if the belt has no visible defects, it may have lost its resilience.



## IMPORTANT

**16)** Operations which lead to impacts, vibrations or localised heating (over 100°C for a maximum of six hours) in the area around the pretensioner may cause damage or make it deploy. Contact an Alfa Romeo Dealership should intervention be necessary on these components.

## CARRYING CHILDREN SAFELY

For optimal protection in the event of an impact, all occupants must be seated and wearing adequate restraint systems, including newborn and other children!

This prescription is compulsory in all EC countries according to EC Directive 2003/20/EC.

Children below the height of 1.50 metres and up to 12 years must be protected with suitable restraint systems and be seated on the rear seats. Statistics on accidents indicate that the rear seats offer greater safety for children.

Compared with an adult, a child's head is larger and heavier in proportion to their body and the child's muscular and bone structures are not fully developed. Therefore, correct restraint systems other than adult seat belts are necessary to reduce as much as possible the risk of injuries in case of accident, braking or sudden manoeuvre.

Children must be seated safely and comfortably. Depending on the characteristics of the child restraint systems used, you are advised to keep children in rearward facing child restraint systems for as long as possible (at least until 3-4 years old), since this is the most protected position in the event of an impact.  63) 64) 65) 66)

The choice of the most suitable child restraint device depends on the weight of the child; there are various types of child restraint systems and you are advised always to choose the one that is most suitable for the child.

When over 1.50 m in height, from the point of view of restraint systems, children are considered as adults and wear seat belts normally.

In Europe the characteristics of child restraint systems are ruled by the regulation ECE-R44, dividing them into five weight groups:

Group	Weight groups
Group 0	up to 10 kg in weight
Group 0+	up to 13 kg in weight
Group 1	9 - 18 kg
Group 2	15 - 25 kg
Group 3	22 - 36 kg

**All restraint devices must bear the certification data, together with the control mark, on a label solidly fixed to the child restraint system which must never be removed.**

Lineaccessori MOPAR® includes child restraint systems for each weight group.

These devices are recommended having been specifically tested for Alfa Romeo cars.



### WARNING

**63) SEVERE DANGER** When a front passenger airbag is fitted, do not install rearward facing child restraint systems on the front passenger seat. Deployment of the airbag in an accident could cause fatal injuries to the child regardless of the severity of the collision. It is advisable to always carry children in a child restraint system on the rear seat, which is the most protected position in the event of a collision.

**64)** On the sun visor there is a label with suitable symbols reminding the user that it is compulsory to deactivate the airbag if a rearward facing child restraint system is fitted. Always comply with the instructions on the passenger side sun visor (see the "Supplementary Restraint System (SRS) - Airbag" paragraph).

**65)** Should it be necessary to carry a child on the passenger side front seat in a rear facing child restraint system, the passenger side front airbag and side bag must be deactivated through the display main menu (see the "Display" paragraph, "Knowing the instrument panel" chapter), verifying deactivation by checking whether the  OFF LED has switched on in the trim located on the dashboard. Move the passenger's seat as far back as possible to avoid contact between the child seat and the dashboard.



ABC

**66)** Do not move the front or rear seat if a child is seated on it or on the dedicated child restraint system

## FITTING "UNIVERSAL" CHILD RESTRAINT SYSTEM (with seat belts)

### GROUP 0 and 0+

**!** 68) 69) 70) 71) 72)

Babies up to 13 kg must be carried with a rear facing child restraint system of a type as shown in fig. 50 which, supporting the head, does not induce stress on the neck in the event of sudden decelerations.

The child restraint system is secured by the vehicle seat belts, as shown in fig. 50 and it must restrain the child in turn with its own belts.



50

AOK0014C

### GROUP 1

**!** 67) 68) 69) 70) 71) 72)

Children of weight from 9 to 18 kg may be transported in forward facing child restraint systems fig. 51.



51

AOK0129C

### GROUP 2

**!** 68) 69) 70) 71) 72)

Children from 15 to 25 kg may be restrained directly by the car seat belts fig. 52.



52

AOK0016C

In this case, the child restraint system is used to position the child correctly with respect to the seat belts so that the diagonal belt section crosses the child's

chest and not the neck, and the lower part is snug on the pelvis not the abdomen.

### GROUP 3

 68) 69) 70) 71) 72)

For children between 22 kg and 36 kg, there are dedicated restraint systems that allow the seat belt to be worn correctly.

The fig. 53 shows the correct child positioning on the rear seat.



53

AOK0017C

Children over 1.50 m in height can wear seat belts like adults.



ABC

## PASSENGER SEAT COMPLIANCE WITH REGULATIONS ON UNIVERSAL CHILD RESTRAINT SYSTEM USE

According to the European Directive 2000/3/EC the suitability of each passenger seat position for the fixing of universal child restraint systems is shown in the following table:

Positioning the "Universal" child restraint system				
Group	Weight groups	Front passenger (*)		Rear passengers (side and central)
		Airbag enabled	Airbag disabled	
Group 0, 0+	up to 13 kg	"X"	U	U
Group 1	9-18 kg	"X"	U	U
Group 2	15-25 kg	U	U	U
Group 3	22-36 kg	U	U	U

(\*) IMPORTANT NEVER fit a rearward-facing child seat in the front passenger seat if the airbag is active. If you wish to fit a rearward-facing child seat in the front passenger seat, first deactivate the relative airbag (see instructions in the paragraph "Supplementary protection system (SRS) - Airbag").

"X"= Position not suitable for children in this weight category.

U= Suitable for child restraint systems in the "Universal" category, according to European Regulation EEC-R44 for the specified "Groups".



### WARNING

- 67)** Child restraint systems with Isofix attachments are available for a safe anchoring to the seat without using the car seat belts. See paragraph "Isofix child restraint system setup" for the fitting instructions.
- 68)** The diagram is indicative and for fitting purposes only. Fit the child restraint system according to the instructions, which must be included.
- 69)** When the child restraint system is not used, secure it with the seat belt or with the ISOFIX anchorages, or remove it from the vehicle. Do not leave it unsecured inside the passenger compartment. In this way, in the case of sudden braking or an accident, it will not cause injuries to the occupants.
- 70)** After installing a child restraint system, do not move the seat: always remove the child restraint system before making any adjustment.
- 71)** Always make sure that the diagonal section of the seat belt does not pass under the arms or behind the back of the child. In the event of an accident the seat belt will not be able to secure the child, with the risk of injury, including fatal injury. Therefore the child must always wear the seat belt correctly.
- 72)** Incorrect fitting of the child restraint system may result in an inefficient protection system. In the event of an accident the child restraint system may become loose and the child may be injured, even fatally. When fitting a restraint system for newborns or children, strictly comply with the instructions provided by the Manufacturer.



## ISOFIX CHILD RESTRAINT SYSTEM SETUP



73)

The vehicle is equipped with ISOFIX anchorages, a new standard which makes fitting a child restraint system quick, simple and safe.

Traditional child restraint systems can be fitted alongside Isofix child restraint systems on different seats in the same car.

As an example, fig. 54 shows an example of a Universal Isofix child restraint system for weight group 1.

**IMPORTANT** The central rear seat is not approved for any type of Isofix child restraint system.



54

A0J0093C

## INSTALLING A UNIVERSAL ISOFIX CHILD RESTRAINT SYSTEM

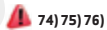

74) 75) 76)

Proceed as follows:

- attach the seat to the lower metal rings provided 1 fig. 55, positioned between the backrest and rear seat cushion, then;
- secure the upper belt (available together with the child restraint system) to the special attachments 2 fig. 56 located in the rear part of the backrest.



55

A0J0092C

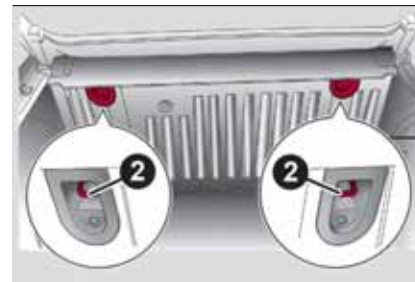

56

A0J0335C

It is possible to have a mixed assembly of traditional child restraint systems and Universal Isofix ones. Remember that when using a Universal Isofix child restraint system, you can only use approved child restraint systems with the marking ECE R44 (R44/03 or superior) "Universal Isofix".

The Universal Isofix "Duo Plus" child seat is available from Lineaccessori MOPAR®. For any further installation/usage details, refer to the "Instruction Manual" provided with the child restraint system.



ABC

## SUITABILITY OF PASSENGER SEATS FOR ISOFIX CHILD RESTRAINT SYSTEM USE

The table below shows the various installation possibilities for Isofix child restraint systems on seats fitted with Isofix attachments in accordance with European standard ECE 16.

Weight group	Child restraint system position	Isofix size class	Rear passenger
			Rear side positions
Group 0 up to 10 kg	Rear facing	E	X
	Rear facing	E	X
Group 0+ up to 13 kg	Rear facing	D	X
	Rear facing	C	X
	Rear facing	D	X
	Rear facing	C	X
	Rear facing	C	X
Group 1 from 9 up to 18 kg	Forward facing	B	IUF
	Forward facing	B1	IUF
	Forward facing	A	X

X Isofix position not suitable for Isofix retaining system in this weight group and/or size class.

IUF: suitable for Isofix child restraint systems to be positioned in forward facing position, universal class (fitted with third upper mounting), type-approved for the relevant weight group.

NOTE: The other weight groups are covered by specific Isofix child restraint systems, which can be used only if specifically tested for this vehicle (see list of vehicles provided with the child restraint system).

## Main recommendations to carry children safely

- ❑ Install the child restraint systems on the rear seat, which is the most protected position in the event of an impact.
- ❑ Keep children in rearward facing child restraint systems for as long as possible, at least until 3–4 years old.
- ❑ Should a rearward facing child restraint system be installed on the rear seats, it is advisable to position it as far forward as the position of the front seat allows.
- ❑ If the passenger side front airbag is deactivated always check the permanent switching on of the warning light  in the trim above the interior rear view mirror to make sure that it has actually been deactivated.
- ❑ Carefully follow the instructions supplied with the child restraint system itself. Keep the instructions in the vehicle along with the other documents and this handbook. Do not use second-hand child restraint systems without instructions.
- ❑ Only one child is to be strapped into each restraint system; never carry two children simultaneously.
- ❑ Always check that the seat belts do not rest on the child's neck.
- ❑ Always check that the seat belt is well fastened by pulling on it.
- ❑ While travelling, do not let the child sit incorrectly or unfasten the belts.

- ❑ Never allow a child to put the belt's diagonal section under an arm or behind their back.
- ❑ Never carry children on your lap, even newborns. No one can hold a child in the case of an accident.
- ❑ In the event of an accident, replace the child restraint system with a new one. In addition, and depending on the type of child restraint system installed, replace the seat belt with which the child restraint system was connected.



### WARNING

**73)** The diagram is indicative and for fitting purposes only. Fit the child restraint system according to the instructions, which must be included.

**74)** If a Universal ISOFIX child seat system is not fixed to all three anchorages, it will not be able to protect the child correctly. In a crash, the child could be seriously or fatally injured.

**75)** Fit the child restraint system when the car is stationary. The child restraint system is correctly secured to the brackets when you hear the click. Follow the instructions for assembly, disassembly and positioning that the Manufacturer must supply with the child restraint system.

**76)** Do not use the same lower anchorage to install more than one child restraint system.

## FRONT AIRBAGS

 77) 78) 79) 80) 81)

### “SMART BAG” SYSTEM (MULTISTAGE FRONT AIRBAGS)

The car features multistage front airbags (“Smart bag”) for driver and passenger.

The front driver/passenger airbags are designed to protect occupants in the event of frontal impacts of medium-high severity, by placing the bag between the occupant and the steering wheel or dashboard.

Therefore non-activation in other types of collisions (side collisions, rear shunts, roll-overs, etc.) is not a system malfunction.

Airbags are not a replacement of but complementary to the seat belts, which you are recommended to always wear. In the event of impact, those not wearing a seat belt are projected forwards and may come into contact with the bag which is still inflating. The protection offered by the bag is compromised in these circumstances.

Front airbags may not activate in the following situations:

- ❑ frontal impacts against highly deformable objects not involving the front surface of the car (e.g. wing collision against guard rail, etc.);



ABC

❑ jamming of the car underneath other vehicles or protective barriers (e.g. underneath a truck or a guard rail) as, in this case, the bags would offer no additional protection with respect to the seat belt and their deployment would be inappropriate. Failure to activate in the conditions described above is due to the fact that they may not provide any additional protection compared with seat belts, so their activation would be inappropriate. In these cases, non-deployment does not indicate a system malfunction.

### FRONT AIRBAG DRIVER'S SIDE

This consists of an instantly inflating cushion contained in a special compartment in the centre of the steering wheel fig. 57.



57

AOJ0047C

### PASSENGER SIDE FRONT AIRBAG

This consists of an instantly inflating bag contained in a special recess in the dashboard fig. 58 which has a larger volume than that of the driver.



58

AOJ0050C

### FRONT PASSENGER SIDE AIRBAG AND CHILD RESTRAINT SYSTEMS

Rearward facing child restraint systems must **NEVER** be fitted on the front seat with an active passenger airbag since in the event of an impact the airbag activation may cause fatal injuries to the transported child. **ALWAYS** comply with the instructions on the label on the passenger side sun visor fig. 59.



59

AOJ0450C

### Deactivating passenger side airbags: front airbag and side bag for pelvis, chest protection (Side bag)

If a child must be carried on the front seat in a rear facing child restraint system, deactivate the passenger side front airbag and side bag for pelvis, chest protection (Side bag). To deactivate the airbags use the Setup Menu (see the instructions in the "Display" paragraph, "Knowing the instrument panel" chapter).

With airbags deactivated, a warning light  lights up on the instrument panel in the trim located above the internal rearview mirror fig. 60.

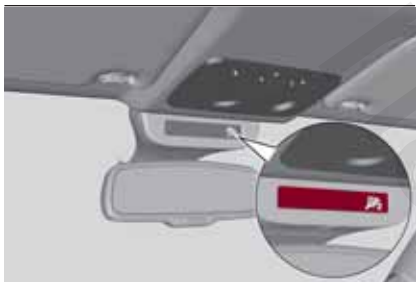

60

A0J0402C

With front passenger airbag on, when the ignition key is turned to MAR, the warning light switches on constantly for several seconds and then it should switch off.

If the warning light flashes, this indicates a fault in the warning light. Before proceeding, contact an Alfa Romeo Dealership to have the system checked immediately.

Rotating the starting device to MAR, the warning light switches on for a few seconds. If not, contact an Alfa Romeo Dealership. During the first seconds, the activation of the warning light does not actually show the passenger protection status, but only tests its correct operation. After a test of a few seconds, the warning light will indicate the status of the passenger airbag protection.

**Passenger protection active:** warning light switches off.

**Passenger protection deactivated:** the warning light switches on with a steady light.

The warning light may light up with various intensity levels depending on the vehicle conditions. The intensity may vary during the same key cycle.

### DRIVER SIDE KNEE BAG

This is located in a dedicated compartment under the steering wheel fig. 61. It provides additional protection in the event of a frontal impact.



61

A0J0056C



ABC

## PASSENGER SIDE FRONT AIRBAG AND CHILD RESTRAINT SYSTEMS: IMPORTANT

I	RISCHIO DI FERITE GRAVI O MORTALI. I seggiolini bambino che si montano nel verso opposto a quello di marcia non vanno installati sui sedili anteriori in presenza di air bag passeggero attivo.
GB	DEATH OR SERIOUS INJURY CAN OCCUR. NEVER use a rearward facing child restraint on a seat protected by an ACTIVE AIRBAG in front of it, DEATH or SERIOUS INJURY to the CHILD can occur
F	RISQUE DE MORT OU DE BLESSURES GRAVES. NE PAS positionner le siège pour enfant tourné vers l'arrière, en cas d'air bag passager actif.
D	Nichtbeachtung kann TOD oder SCHWERE VERLETZUNGEN zur Folge haben. Rückwärts gerichtete Kinderrückhaltesysteme (Babyschale) dürfen nicht in Verbindung mit aktiviertem Beifahrerairbag auf dem Beifahrersitz verwendet werden
NL	DIT KAN DODELIJK ZIJN OF ERNSTIGE ONGELUKKEN VEROORZAKEN. Plaats het kinderstoeltje niet ruggelings op de voorstoel wanneer er een airbag aanwezig is.
E	PUEDE OCACIONAR MUERTE O HERIDAS GRAVES. NO ubicar el asiento para niños en sentido inverso al de marcha en el asiento delantero si hubiese airbag activo lado pasajero.
PL	MOŻE GROZIĆ ŚMIERCIĄ LUB CIEŻKIMI OBRAŻENIAMI. NIE WOLNO umieszczać fotelika dziecięcego tyłem do kierunku jazdy na przednim siedzeniu w przypadku zainstalowanej aktywnej poduszki powietrznej pasażera.
TR	ÖLÜM VEYA AĞIR ŞEKİLDE YARALANMAYA SEBEP OLABİLİR. Yolcu airbağı aktif halde iken çocuk koltuğunu araç gidisi yönüne ters biçimde yerleştirmeyin.
DK	FARE FOR DØDELIGE KVÆSTELSER OG LIVSTRUENDE SKADER. Placer aldrig en bagudvendt barnstol på passagerersædet, hvis passager-airbagen er indstillet til at være aktiv (on).
EST	TAGAJÄRJEKS VÕIVAD OLLA TÕSISED KEHAVIGASTUSED VÕI SURM. Turvapäidja olemasolu korral ärge asetage lapse turvaistet sõidusuuna vastassuunas.
FIN	KUOLEMANVAARA TAI VAKAVIEN VAMMOJEN UHKA. Älä aseta lasten turvaistuinta niin, että lapsi on selkä menosuuntaan, kun matkustajan airbag on käytössä.
P	RISCO DE MORTE OU FERIMENTOS GRAVES. Não posicionar o banco para crianças numa posição contrária ao sentido de marcha quando o airbag de passageiro estiver activo.
LT	GALI IŠTIKTI MIRTIS ARBA GALITE RIMTAI SUSIŽEISTI. Nedėkite vaiko sėdynės atgretos nugarą į priekinį automobilio stiklą ten, kur yra veikiant keleivio oro pagalvė.
S	KAN VARA LIVSHOTANDE ELLER LEDA TILL ALLVARLIGA SKADOR. Placera aldrig en bakåtvänd barnstol i framsätet då passagerarsidans krockkudde är aktiv.
H	HALÁSOS VAGY SÜLYOS BALESET KÖVETKEZHET BE. Ne helyezzük a gyermekülést a menetiránnyal szembe, ha az utas oldalán légszák működik.
LV	VAR IZRAISĪT NĀVI VAI NOPIETNAS TRAUMAS. Nenovietot mazuļa sēdekli pretēji braukšanas virzienam, ja pasažiera pusē ir uzstādīts gaisa spilvens.
CZ	HROZÍ NEBEZPEČÍ VÁŽNĚHO UBLÍŽENÍ NA ZDRAVÍ NEBO DOKONCE SMRTI. Neumísťujte detskou sedačku do opačné polohy vúči smrti jazdy v prípade aktívneho airbagu spolujazdca.
SLO	LAHKO PRIDE DO SMRTI ALI HUDIH POŠKODB. Otroškega avtomobilskega sedeža ne nameščajte v obratni smeri vožnje, če ima vozilo vgrajene zračne blazine za potnike.
RO	SE POATE PRODUCÉ DECESUL SAU LEZIUNI GRAVE. Nu aşezaţi scaunul de maşină pentru bebeluşi în poziţie contrară direcţiei de mers atunci când airbag-ul pasagerului este activat.
GR	ΜΠΟΡΕΙ ΝΑ ΠΡΟΚΛΗΘΟΥΝ ΘΑΝΑΤΟΣ Ή ΣΩΒΑΡΑ ΤΡΑΥΜΑΤΑ. Μην τοποθετείτε το καρεκλάκι αυτοκινήτου για παιδιά σε αντίθετη προς την φορά πορείας θέση σε περίπτωση που υπάρχει αερόσακος εν ενεργεία στη θέση συνεπιβάτη.
BG	ИМА ОПАСНОСТ ОТ СМЪРТ И СЕРИОЗНИ НАРАНЯВАНИЯ. Не поставяйте столчето за пренасяне на бебета в положение обратно на посоката на движение, при положение активно на въздушната възглавница за пътуване.
SK	MŮŽE NASTAŤ SMŤ ALEBO VÁŽNE ZRANENIA. Nedávajte autosedačku pre deti do polohy proti chodu vozidla, keď je aktívny airbag spolujazdca.
RUS	ТРАВМЫ И ЛЕТАЛЬНЫЙ ИСХОД. Детское кресло, устанавливающееся против направления движения, нельзя монтировать на месте переднего пассажира, если последнее оборудовано активной подушкой безопасности.
HR	OPASNOST OD TEŠKIH ILI SMRTONOSNIH OZLJEDA. Sjedala za djecu koja se montiraju u smjeru suprotnom od vožnje ne smiju se instalirati na prednja sjedala ako postoji aktivni zračni jastuk suvozača.
AS	قد تحدث حالات وفاة أو إصابات بالغة. لا تستخدم مقاعد الأمان الخاصة بالأطفال على مقعد مزود "بوسادة هوائية"، حيث إن الطفل قد يتعرض للوفاة أو لإصابة بالغة.



## WARNING

**77)** Do not apply stickers or other objects on the steering wheel, on the dashboard in the passenger side airbag area, on side upholstery on the roof or on the seats. Never put objects (e.g. mobile phones) on the passenger's side dashboard since they could interfere with correct inflation of the airbag and also cause serious injury to the passengers.

**78)** Always drive keeping your hands on the steering wheel rim so the airbag can inflate freely if necessary. Do not drive with your body bent forward. Keep the back of your seat upright and lean back into it.

**79)** When there is an active passenger airbag, DO NOT install rearward facing child restraint systems on the front seat. Deployment of the airbag in an accident could cause fatal injuries to the child regardless of the severity of the impact. Therefore, always deactivate the passenger side airbag when a rearward facing child restraint system is installed on the front passenger seat. The front passenger seat must also be positioned back as far as possible in order to prevent the child restraint system from coming into contact with the dashboard. Immediately reactivate the passenger airbag as soon as the child restraint system has been removed.

**80)** To deactivate the airbags, see the "Knowing your car" section, "Menu items" paragraph.

**81)** A failure of the  warning light is indicated by the  warning light switching on. In addition, the airbag system automatically disables the passenger side airbag (where provided). Before proceeding, contact an Alfa Romeo Dealership to have the system checked immediately.



ABC

## SIDE AIRBAGS (SIDE BAG - WINDOW BAG)

To increase protection of occupants in case of side collision, the car is equipped with front side bags for pelvis, chest protection (side bags) for the driver and the passenger and airbags protecting the head of front and rear occupants (window bags).

Non-activation of side bags in other types of collisions (front collisions, rear shunts, roll-overs, etc.) is not a system malfunction.

### FRONT SIDE AIRBAGS (SIDE BAGS)

These comprise two bags located in the front seat backrests fig. 63 which protect the pelvic and chest area of the occupants in the event of a side impact of medium-high severity.



63

AOJ0103C

## SIDE AIRBAGS FOR HEAD PROTECTION (WINDOW BAGS)

These consist of two “drop-down” cushions, housed behind the side trim of the roof and covered with finishing elements fig. 64.

They are designed to protect the head of front and rear occupants in the event of a side collision, thanks to the wide cushion inflation surface.



64

AOJ0051C

The deployment of side bags in the event of side impacts of low severity is not required.

The airbags are not deployed in the event of impact of low severity (for which the restraining action of the seat belts is sufficient). It is therefore always necessary to wear seat belts.

In the event of a side impact, the system provides best protection if the passenger

sits on the seat in a correct position, thus allowing correct window bag deployment.

## IMPORTANT NOTES

 82) 83) 84) 85) 86) 87) 88) 89) 90) 91) 92)

Do not wash the seats with water or pressurised steam (wash by hand or at automatic seat washing stations).

The front and/or side bags may activate in the event of sharp knocks to the underbody of the car (e.g. impact with steps, pavements, potholes or road bumps etc.).

When the airbag deploys it emits a small amount of dust: the dust is harmless and does not indicate the beginning of a fire. However, the dust may irritate the skin and eyes: in this case, wash with neutral soap and water.

Airbag checking, repair and replacement must be carried out at an Alfa Romeo Dealership.

If the car is scrapped, have the airbag system deactivated at an Alfa Romeo Dealership.

Pretensioners and airbags are deployed according to different logic on the basis of the type of collision. Failure to activate one or more of the devices does not indicate a system malfunction.





## WARNING

- 82)** Do not affix rigid objects to the garment hooks or support handles.
- 83)** Do not rest your head, arms or elbows on the door, windows or the area in which the Window bag is located to avoid possible injury during airbag inflation.
- 84)** Never lean your head, arms or elbows out of the window.
- 85)** If the  warning light does not switch on when the key is turned to MAR, or stays on while driving (on some versions together with a message on the display) there may be a fault in the restraint systems. In this case, airbags or pretensioners may not be activated in the case of an accident or (in a lesser number of cases) they may be activated incorrectly. Before proceeding, contact an Alfa Romeo Dealership to have the system checked immediately.
- 86)** Do not travel carrying objects on your lap, in front of your chest or between your lips (pipe, pencils, etc.): they could cause severe injury if the airbag is deployed.
- 87)** If the car has been subject to theft, attempted theft, vandalism, or flooding, have the airbag system inspected at an Alfa Romeo Dealership.

**88)** The airbags may also be deployed when the car is not moving, if the key is in the ignition and turned to MAR-ON or when the engine is off, if the car is hit by another moving vehicle. Therefore, even if the vehicle is stationary, when an active front passenger airbag is fitted, DO NOT install rearward facing child restraint systems on the front passenger seat. Deployment of the airbag following an impact could cause fatal injuries to the child. Therefore, always deactivate the passenger side airbag when a rearward facing child restraint system is installed on the front passenger seat. The front passenger seat must also be positioned back as far as possible in order to prevent the child restraint system from coming into contact with the dashboard. Immediately reactivate the passenger airbag as soon as the child restraint system has been removed. Also remember that, if the key is turned to STOP, none of the safety devices (airbags or pretensioners) will be deployed in the event of collision. Non-deployment in such cases does not indicate a system malfunction.

**89)** When the ignition key is turned to MAR, the  warning light switches for few seconds, then if the passenger airbag is active it should switch off.

**90)** The front airbag is designed to be deployed for impacts of a greater intensity than for the pretensioners. For impacts whose intensity falls between the two levels, normally, only the pretensioners will be activated.

**91)** The airbag does not replace seat belts but increases their efficiency. Because front airbags are not deployed for low-speed crashes, side collisions, rear-end shunts or rollovers, occupants are protected, in addition to any side bags, only by their seat belts, which must therefore always be fastened.

**92)** On cars with side bags, do not cover the front seat backrests with extra covers.



basic.ele.cir

*This page is intentionally left blank*



## STARTING AND DRIVING

STARTING THE ENGINE . . . . .	90
PARKING THE VEHICLE . . . . .	91
USING THE MANUAL GEARBOX . . . . .	92
USING ALFA TCT TRANSMISSION . . . . .	93
START&STOP SYSTEM. . . . .	95
CRUISE CONTROL . . . . .	97
PARKING SENSORS . . . . .	98
TOWING TRAILERS . . . . .	99
REFUELLING THE VEHICLE . . . . .	100

Let's get to the core of the vehicle: seeing how you can exploit all of its potential to the full. We'll look at how to drive it safely in any situation, so that it can be a welcome companion, with our comfort and our wallets in mind.

## STARTING THE ENGINE



93) 94) 95)

17) 18) 19) 20)

Before starting the engine, adjust the seat, the interior rear view mirrors, the door mirrors and fasten the seat belt correctly.

Never press the accelerator pedal for starting the engine.

If necessary, messages indicating the starting procedure can be shown on the display.

### PROCEDURE FOR PETROL VERSIONS

#### Except Turbo TwinAir versions

Proceed as follows:

- engage the handbrake and place the gearbox lever in neutral;
- fully depress the clutch pedal, without touching the accelerator;
- turn the ignition key to AVV and release it as soon as the engine starts.

#### Turbo TwinAir versions

Proceed as follows:

- engage the handbrake and place the gear lever in neutral or fully press the clutch pedal if a gear other than neutral is engaged;
- turn the ignition key to AVV and release it as soon as the engine starts.

### Versions with LPG system

To properly perform the starting procedure, refer to as previously described.

The engine always starts up on petrol independently of the mode previously selected. There must therefore always be some petrol in the tank to protect the petrol pump and to guarantee temporary switching from LPG to petrol operation, if high performance is required.

#### IMPORTANT NOTES

**Except Turbo TwinAir versions:** If the engine does not start at the first attempt, return the ignition key to STOP before repeating the procedure.

**For Turbo TwinAir versions only:** If the vehicle does not start at the first attempt, return the ignition key to STOP and repeat the starting procedure placing the gear lever in neutral and fully pressing the clutch pedal.

If, with the ignition key turned to MAR, the symbol is shown on the display together with the warning light , turn the key to STOP and then back to MAR. If the symbol on the display is still shown, try with the other keys provided with the car. Contact an Alfa Romeo Dealership if the engine still does not start.

Never leave the ignition key in MAR-ON position when the engine is stopped.

### PROCEDURE FOR DIESEL VERSIONS

Proceed as follows:

- engage the handbrake and place the gear lever in neutral;
- turn the ignition key to MAR position: the warning light will light up on instrument panel;
- wait for the warning light to switch off;
- fully depress the clutch pedal, without touching the accelerator;
- turn the ignition key to AVV; the warning light switches off. Waiting too long will waste the heating work carried out by the glow plugs. Release the key as soon as the engine starts.



#### WARNING

**93)** It is dangerous to run the engine in enclosed areas. The engine takes in oxygen and releases carbon dioxide, carbon monoxide and other toxic gases.

**94)** The brake servo is not active until the engine is started, so you would need to apply much more force than usual to the brake pedal.

**95)** Do not start the engine by pushing, towing or driving downhill. These manoeuvres may damage the catalytic converter.



## IMPORTANT

**17)** We recommend that during the initial period, or during the first 1 600 km (1 000 miles), you do not drive to full car performance (e.g. excessive acceleration, long journeys at top speed, sharp braking, etc.).

**18)** When the engine is switched off never leave the ignition device in the MAR position to prevent useless current absorption from draining the battery.

**19)** A quick burst on the accelerator before turning off the engine serves absolutely no practical purpose; it wastes fuel and is damaging for the engine.

**20)** Warning light  will flash after starting or during prolonged cranking to indicate a fault with the glow plug heating system. If the engine starts, the vehicle can be regularly used, but an Alfa Romeo Dealership must be contacted as soon as possible.

## PARKING THE VEHICLE



96|97)

Always remove the ignition key when leaving the car.

When parking and leaving the car, proceed as follows:

- engage a gear (1<sup>st</sup> gear if facing uphill or reverse if facing downhill) and leave the wheels turned;
- stop the engine and engage the handbrake.

Block the wheels with a wedge or a stone if the car is parked on a steep slope.

On versions equipped with Alfa TCT transmission, before releasing the brake pedal, wait for letter P to be displayed.

**IMPORTANT NEVER** leave the car with the gearbox in neutral (or, on versions equipped with Alfa TCT transmission, before placing the gear lever at P).

### HANDBRAKE

To engage the handbrake, pull lever 1 fig. 65 upwards until the car is secured.

When the handbrake is engaged and the ignition key is on MAR-ON, the instrument panel warning light  will switch on.

To release it, raise lever 1 slightly, hold down button 2 and lower the lever: the warning light  on the instrument panel switches off.

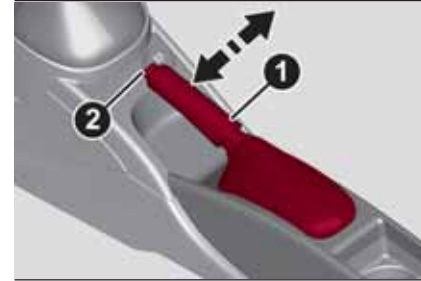

65

A0J0110C

**IMPORTANT** Carry out these manoeuvres with the brake pedal pressed.

**IMPORTANT** For cars equipped with a front armrest, lift it up to ensure that it does not interfere with the action of the handbrake.



## WARNING

**96)** Never leave children unattended in the car. Always remove the key from the ignition when leaving the car and take it with you.

**97)** The car should be braked after a few clicks of the parking brake: if this is not so, contact an Alfa Romeo Dealership to have it adjusted. Always park the car safely as indicated by the Highway Code and as described above.



ABC

## USING THE MANUAL GEARBOX

 98)

 21)

To engage the gears, fully depress the clutch pedal and put the gear lever into the required position (the diagram is shown on the knob fig. 66, fig. 67, fig. 68).

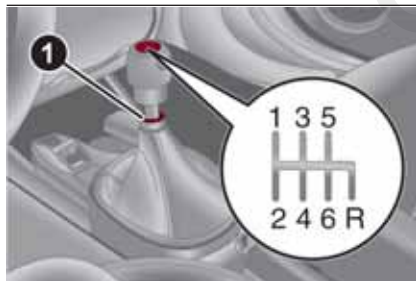

66

A0J0265C

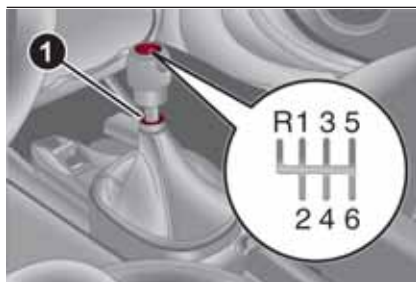

67

A0J0266C

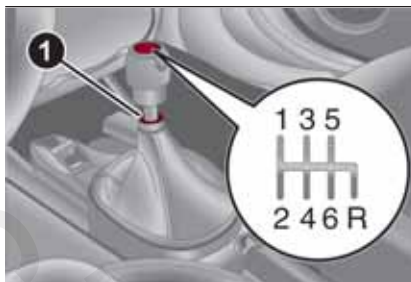

68

A0J0267C

In models with 6 gears, to engage 6<sup>th</sup> gear, move the gearstick to the right to avoid changing into 4<sup>th</sup> by mistake. The same applies to the shift from 6<sup>th</sup> to 5<sup>th</sup> gear.

To engage reverse (R) from neutral position, raise ring 1 underneath the knob and, at the same time:

on 1.4 Turbo Multi Air 170 HP Veloce versions, move the lever to the left and then forwards fig. 67;

on Turbo TwinAir, 1.4 Petrol, 1.4 Turbo MultiAir and 1.3 JTD<sub>M-2</sub> versions, move the lever to the right and then backwards fig. 66, fig. 68.

**IMPORTANT** Reverse can only be engaged when the vehicle is completely stationary.



### WARNING

**98)** Press the clutch pedal fully to change gears correctly. It is therefore essential that there is nothing under the pedals: make sure the mats are lying flat and do not get in the way of the pedals.



### IMPORTANT

**21)** Do not drive with your hand resting on the gear lever as the force exerted, even if slight, could lead over time to premature wear of the gearbox internal components.

## USING ALFA TCT TRANSMISSION

(where provided)



### SELECTOR LEVER

The fig. 69 lever has the following positions:

The fig. 70 lever has the following positions:

- P** = Park
- R** = Reverse
- N** = Neutral
- D** = Drive, (automatic forward speed)
- +** = Sequential upshifting
- = Sequential downshifting



69

A0J0360C



70

A0J0367C

If the lever is used in sequential mode, moving the latter from D to the left, the positions towards + or - are unstable.

The lever has a button 1 (on the front side, see figure), which must be pressed to move the lever to P or R.

Shifting from D to "Sequential mode" and vice versa is free.

Shifting from D to N is free.

Shifting from N to R and from R to P is possible only with button on gear lever pressed.

### STARTING THE ENGINE

Starting is only permitted with gear lever in position P or N (with or without brake pedal pressed).

On starting, the system is at N or P (the latter means neutral, but with the car's wheels locked mechanically).

### SWITCHING OFF THE ENGINE

Engine can be switched off in any position of the gear lever.

#### Versions with Start&Stop system

To switch the engine off, you need to stop the car by pressing the brake pedal properly; if the pressure is not enough, the engine will not be switched off. This feature can be exploited so that the engine does not switch off in particular traffic conditions.

### REMOVING THE IGNITION KEY



The ignition key can be removed only with gear lever in P position. For removal procedure, see as described on paragraph "ALFA TCT Transmission - Key removal" in the chapter "In an emergency".

### MOVING THE CAR



To move the car, from P press the brake pedal and, using the button on the gear lever, move the lever to the desired position (D, R or "Sequential mode").

The display will show the gear engaged.

When the brake pedal is released, the car starts moving forwards or backwards, as soon as the manoeuvre is activated ("creeping" effect). The accelerator should not be pressed in this case.



ABC

**IMPORTANT** The inconsistency between the speed actually engaged (shown on the display) and the position of the gear lever is indicated by the letter corresponding to the position of the lever flashing on the trim (also accompanied by an acoustic signal). This condition should not be interpreted as an operational fault, but simply as a request by the system to repeat the manoeuvre.

**IMPORTANT** With handbrake released and brake pedal released, engine at idling speed and gear lever in position D, R or sequential, pay the utmost care because the car can move even without the operation of the accelerator pedal. This condition can be used with the car on a level surface during tight parking manoeuvres using the brake pedal only.

### **AUTOMATIC DRIVING MODE**

D can be selected from sequential operation in any driving conditions. In automatic driving mode, the best ratio is selected by the electronic transmission control unit depending on speed, engine load (accelerator pedal position) and gradient of the road.

### **"Kick-Down" function**

To resume speed quickly, when the accelerator pedal is pressed fully, the transmission control system downshifts ("Kick-down" function).

**IMPORTANT** When driving on roads with poor grip conditions (snow, ice, etc.) avoid activating the kick-down function.

### **Gearshifting suggestion**

With the transmission in automatic mode (selector lever in position D), when gearshifting is required by the paddles on the steering wheel (where provided), the system shifts to "Sequential mode", displaying the engaged gear for about 5 seconds.

When this time has elapsed, if the paddles are not operated anymore, the system goes back to the automatic mode (D), with following displaying.

### **SEQUENTIAL DRIVING MODE**

In sequential driving mode, the transmission works like a manual gearbox.

### **Gearshifting through selector lever**

Move the lever sideways (to the left) from position D to the sequential position:

- lever towards "+": engage higher gear;
- lever towards "-": engage lower gear.

The lever correct position in "Sequential Mode" is signalled when the symbols "+" and "-" come on and, simultaneously, the symbol D comes off on the display.

The gear engaged is shown on the display.

### **Gearshifting through steering wheel paddles**

(where provided)



To use the paddles on the steering wheel fig. 71, the gear lever must be in sequential position or in D:

To use the paddles on the steering wheel, the gear lever must be in "Sequential mode" or in D:

- steering wheel paddle "+" (pulling paddle towards driver fig. 71 ): engage higher gear;
- steering wheel paddle "-" (pulling paddle towards driver fig. 71 ): engage lower gear.



71

A0J0365C





72

A0J0376C

The upshifting/downshifting is only permitted if the engine revs allow it. If the car is stopped with a higher gear than 1st speed engaged, the transmission will automatically engage 1st gear.



### IMPORTANT

- 22)** If the car is on a gradient, always engage the handbrake **BEFORE** placing the gear lever in P.
- 23)** Engage reverse only with the car stationary, engine at idling speed and accelerator pedal fully released.
- 24)** Using the paddles incorrectly (paddles pushed towards the dashboard) could break them.



### WARNING

**99)** Never leave children unattended in the car. Always remove the ignition key when leaving the car and take the key with you.

## START&STOP SYSTEM

(where provided)



The Start&Stop system automatically stops the engine each time the vehicle is stationary and starts it again when the driver wants to move off. In this way, the vehicle efficiency is increased, by reducing consumption, dangerous gas emissions and sound pollution.

### OPERATING MODE

#### Stopping the engine

With the vehicle stopped, the engine stops with gearbox in neutral and clutch pedal released.

**NOTE** The engine can only be stopped automatically after exceeding about 10 km/h, to prevent the engine from being repeatedly stopped when driving at walking pace.

The symbol  appears on the display when the engine stops.

#### Restarting the engine

To restart the engine, press the clutch pedal.





ABC

## SYSTEM MANUAL ACTIVATION / DEACTIVATION

To activate/deactivate manually the system, press the fig. 73 button on the trim next to the steering wheel.

**Start&Stop system activation:** A message will appear on the display when the Start&Stop system is activated.

**Start&Stop system deactivation:** The  symbol and a message will appear on the display. When the system is deactivated, the  warning light on the instrument panel switches on.



73

A0J0307C

## MISSED ENGINE STOPPING CONDITIONS

 25)

When the system is active, for a higher comfort and safety, and to reduce emissions, the engine does not stop in certain ambient conditions, engine

conditions, with the driver door not closed and driver seat belt unfastened.

## SAFETY FUNCTIONS

When the engine is stopped by the Start&Stop system, if the driver releases his/her seat belt and opens the driver's or passenger's door, the engine can be restarted only by the ignition key.

The driver is informed by a buzzer and by the flashing of the symbol  on the display (on some versions, a message is displayed as well).

## "ENERGY SAVING" FUNCTION (where provided)

If, following the automatic engine restarting, the driver does not carry out any action on the vehicle for over 3 minutes, the Start&Stop system stops the engine definitely, to prevent fuel consumption. In these cases, the engine can be restarted only using the ignition key.

**NOTE** In any case, it is possible to keep the engine running by deactivating the Start&Stop system.

## IRREGULAR OPERATION

In the event of malfunction, the Start&Stop system is deactivated.

The fault is indicated by the  symbol switching on (on some version a specific message is also shown) on the display.

In this case, contact an Alfa Romeo Dealership.

## VEHICLE INACTIVITY

 100)

In the event of vehicle inactivity (or if the battery is replaced), special attention must be paid to the disconnection of the battery power supply.

**IMPORTANT** After turning the ignition key to STOP, wait at least 1 minute before disconnecting the electrical supply to the battery.



### IMPORTANT

**25)** *If climate comfort is to be favoured, the Stop/Start system can be deactivated, for a continuous operation of the climate control system.*



### WARNING

**100)** *When replacing the battery, always contact an Alfa Romeo Dealership. Replace the battery with one of the same type (HEAVY DUTY) and with the same specifications.*

## CRUISE CONTROL

(where provided)



### DESCRIPTION

This is an electronic driving aid that allows you to drive at a speed of above 30 km/h on long and straight dry roads (e.g. motorways), at a preset speed without having to press the accelerator pedal. It is therefore not recommended to use this device on extra-urban roads with traffic. Do not use it in town.

### ACTIVATING THE DEVICE



Turn ring 1 fig. 74 to ON.

The device cannot be engaged in 1<sup>st</sup> or reverse gear: it is advisable to engage it in 5<sup>th</sup> gear or higher.



74

A0J0065C

When travelling downhill with the device engaged, the car may slightly exceed the stored speed.

Activation is indicated by the warning light switching on and, on some versions, by a message on the display.

### SETTING THE DESIRED SPEED

Proceed as follows:

- turn ring 1 fig. 74 to ON and press the accelerator to reach the required speed;
- move the stalk upwards (+) for at least 1 second, then release it: the car speed is now stored and you can therefore release the accelerator.

If needed (when overtaking for instance), you can accelerate simply by pressing the accelerator; when you release the pedal, the vehicle goes back to the speed stored previously.

### RESTORING THE MEMORISED SPEED

If the device has been disengaged by pressing the brake or clutch pedal, the stored speed can be reset as follows:

- accelerate gradually until a speed approaching the one stored is reached;
- engage the gear selected at the time that the speed was stored;
- press the RES 2 fig. 74 button.

### INCREASING THE MEMORISED SPEED

Press the accelerator and store the new speed or move the stalk upwards (+).

### REDUCING THE MEMORISED SPEED

Deactivate the device and store the new speed or move the lever upwards (-) until the new speed is reached. It will then automatically be memorised.

### DEACTIVATING THE DEVICE

To turn the device off:

- Turn the ring 1 fig. 74 to the OFF position;
- or
- switch off the engine;
- or
- press the brake pedal, the clutch or the accelerator; in this last case the system is not effectively deactivated but the system gives priority to the acceleration request. The device still remains active, without the need to press the RES button to return to the previous conditions once acceleration is concluded.

### Automatic deactivation

The device is automatically switched off in the following cases:

- if the ABS or ESC systems intervene;
- with the vehicle speed below the set limit;
- in the event of system failure.



ABC

**WARNING**

**101)** When travelling with the device active, never move the gear lever to neutral.

**102)** In case of a malfunction or failure of the device, contact an Alfa Romeo Dealership.

**PARKING SENSORS**

(where provided)



 **103) 104)**

 **26)**

The sensors are located in the vehicle rear bumper fig. 75 and their function is to inform the driver, through an intermittent acoustic and visual signal, about the presence of obstacles behind the vehicle.

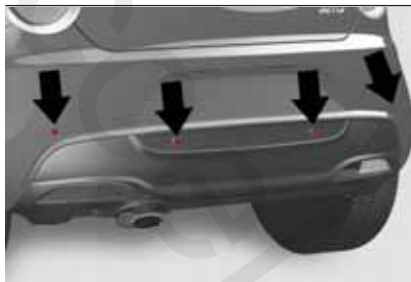

75

A0J0088C

**ACTIVATION/DEACTIVATION**



The sensors are turned on when reverse gear is engaged. As the distance from the obstacle behind the vehicle decreases, the frequency of the acoustic signal increases.

When the reverse gear is disengaged, the sensors deactivate.

**ACOUSTIC SIGNAL**

When reverse gear is engaged an acoustic signal is automatically activated if there is an obstacle within the range of operation.

The acoustic signal:

-  increases as the distance between the vehicle and the obstacle decreases;
-  becomes continuous when the distance between the car and the obstacle is less than 30 cm and stops immediately if the distance increases;
-  remains constant if the distance remains unchanged; if this situation concerns the side sensors, the buzzer will stop after about 3 seconds to avoid, for example, warning indications in the event of manoeuvres along walls.

**OPERATION WITH A TRAILER**

Parking sensor operation is automatically turned off when the trailer electric cable plug is fitted into the car tow hook socket.

**IMPORTANT NOTES**

During parking manoeuvres, pay the utmost attention to any obstacles that could be located above or below the sensors.

Objects set close to the car rear, under certain circumstances are not detected and could therefore cause damage to the car or be damaged.

The following conditions may influence the performance of the parking assistance system:

- ❑ reduced sensor sensitivity and a reduction in the parking assistance system performance could be due to the presence on the surface of the sensor of: ice, snow, mud, thick paint
- ❑ The sensors may detect a non-existent obstacle (echo interference) due to mechanical interference, for example when washing the car, in rain (strong wind), hail.
- ❑ The signals sent by the sensors can also be altered by the presence of ultrasonic systems (e.g. pneumatic brake systems or pneumatic drills) near the vehicle.
- ❑ sensor performance can also be influenced by the position of the sensors. For example by a change in the ride setting (caused by the wear of the shock absorbers, suspension), overloading the car and carrying out specific tuning operations that require the car to be lowered;
- ❑ The detection of obstacles at the top part of the car may not be guaranteed because the system detects obstacles that could cause an impact with the car in the bottom part.



### IMPORTANT

**26)** *The sensor must be free of mud, dirt, snow or ice in order for the system to work. Be careful not to scratch or damage the sensors while cleaning them. Avoid using dry, rough or hard cloths. The sensors must be washed using clean water, with the addition of vehicle shampoo if necessary. When using special washing equipment such as high pressure jets or steam cleaning, clean the sensors very quickly keeping the jet more than 10 cm away.*



### WARNING

**103)** *Only have the bumpers repainted or any retouches to the paintwork in the area of the sensors carried out by an Alfa Romeo Dealership. Incorrect paint application could affect the operation of the parking sensors.*

**104)** *Parking and other dangerous manoeuvres are, however, always the driver's responsibility. While carrying out these manoeuvres, always make sure that no people (especially children) or animals are in the area concerned. The parking sensors are an aid for the driver, but the driver must never allow their attention to lapse during potentially dangerous manoeuvres, even those executed at low speeds.*

## TOWING TRAILERS



105) 106)

### IMPORTANT NOTES

The car must be provided with a type-approved tow hook and adequate electric system to tow caravans or trailers. Installation must be carried out by a specialist.

Install any specific and/or additional door mirrors as specified by the Highway Code.

Remember that when towing a trailer, steep hills are harder to climb, the braking spaces increase and overtaking takes longer depending on the overall weight.

Engage a low gear when driving downhill, rather than constantly using the brake.

The weight of the trailer reduces the load capacity of the car by the same amount. Consider the weight at full load, including accessories and luggage, to make sure you do not exceed the maximum towable weight (shown in the registration document).

Do not exceed the speed limits specific to each country you are driving in, in the case of vehicles towing trailers. In any case do not exceed 100 km/h.



ABC

## INSTALLING A TOW HOOK

Contact an Alfa Romeo Dealership to install a tow hook.



### WARNING

**105)** The ABS with which the car is equipped will not control the braking system of the trailer. Particular caution is therefore required on slippery roads.

**106)** Do not, under any circumstances, modify the vehicle's braking system to control the trailer braking system. The towing braking system must be completely independent of the vehicle's hydraulic system.

## REFUELLING THE VEHICLE



During refuelling procedure, switch off the engine, engage handbrake, rotate the ignition key to STOP and do not smoke.

### PETROL ENGINES

Only use unleaded petrol. The petrol octane rating (RON) must not be lower than 95. In order to prevent damage to the catalytic converter never introduce even the smallest amount of leaded petrol, even in the event of an emergency.

### DIESEL ENGINES

Only use diesel fuel compliant with European specification EN590. The use of other products or mixtures may damage the engine beyond repair and consequently invalidate the warranty, due to the damage caused.

When using or parking the vehicle for a long time in the mountains or cold areas, it is advisable to refuel using locally available Diesel. In this case, it is also advisable to keep the tank over 50% full.

### FUEL TANK CAP



107)

#### Opening

Open flap 1 fig. 76 pulling it outwards, hold cap 2 still, insert the ignition key in the lock and turn it anticlockwise. Then,

turn the cap anticlockwise and remove it. The cap has a loss prevention device 3 which secures it to the flap so that it cannot be lost. Attach the cap to device 4 during refuelling.

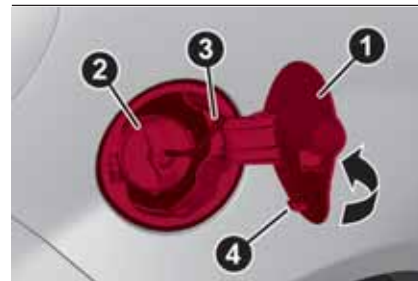

76

A0J0327C

#### Closing

Fit the cap (complete with key) and turn it clockwise until it clicks once or more. Then, turn the key clockwise and extract it, then close the flap.

The sealing may cause a slight pressure increase in the tank. A little breathing off, while slackening the cap is absolutely normal.

### ENGINES WITH LPG SYSTEM

The gas filler is located next to the petrol filler cap. It has a "non return", located in the filler body itself.

To access the filler 2 fig. 77 open the access flap 1.

Observe the following precautions during the refuelling operation:

- switch off the engine;
- apply the handbrake;
- ignition key turned to the OFF position;
- do not smoke;
- hand the special adapter over to the qualified LPG refuelling personnel.

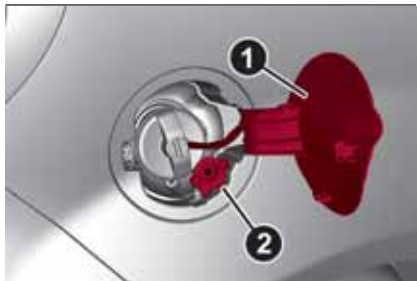

77

A0J0315C

**IMPORTANT** Depending on the country, there are various types of adapters for the refuelling pump. Adapter 3 fig. 78, supplied with the car and located in a special case, is specifically designed for the country in which the car is sold. If you are in a different country, find out what type of adapter is used there.

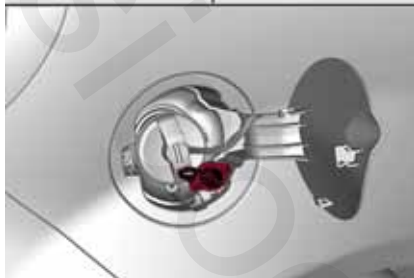

78

A0J0320C



#### WARNING

**107)** Do not bring naked flames or lit cigarettes near to the fuel tank opening; fire risk. Keep your face away from the fuel filler to prevent breathing in harmful vapours.



ABC

basicsele.ir

*This page is intentionally left blank*





## IN AN EMERGENCY

HAZARD WARNING LIGHTS . . . . .	.104
REPLACING A BULB . . . . .	.104
REPLACING AN EXTERIOR BULB . . . . .	.108
REPLACING FUSES . . . . .	.110
CHANGING A WHEEL . . . . .	.116
"Fix&Go Automatic" KIT . . . . .	.120
JUMP STARTING . . . . .	.122
FUEL CUT-OFF SYSTEM . . . . .	.123
ALFA TCT TRANSMISSION - KEY REMOVAL . . . . .	.124
TOWING THE VEHICLE . . . . .	.125

A punctured tyre or a burnt-out bulb?  
At times, a problem may interfere with our journey.  
The pages on emergencies can help you to deal with critical situations independently and with calm. In an emergency we recommend that you call the freephone number found in the Warranty Booklet. You can also use the universal, national or international freephone number to find your nearest Authorised Alfa Romeo Dealership.

## HAZARD WARNING LIGHTS



108)

### Operation

Press switch 1 fig. 79 to turn the lights on/off.

Warning lights ← and → are lit up on the instrument panel when these lights are activated.



79

A0J0028C

### Emergency braking

In the event of emergency braking the hazard warning lights switch on automatically as well as warning lights ← and → in the instrument panel.

The lights are switched off automatically when the nature of braking changes.



## WARNING

**108)** *The use of hazard warning lights is governed by the highway code of the country you are driving in: comply with legal requirements.*

## REPLACING A BULB



109) 110) 111)



27)

### GENERAL INSTRUCTIONS

- Check that the corresponding contacts are not oxidised and that the corresponding fuse is intact before changing the bulb. For the location of fuses, refer to the paragraph "If a fuse blows" in this chapter.
- replace blown bulbs with others of the same type and power;
- after replacing a headlight bulb, always check its alignment;

**IMPORTANT** When the weather is cold or damp or after heavy rain or washing, the surface of headlights or rear lights may steam up and/or form drops of condensation on the inside. This is a natural phenomenon due to the difference in temperature and humidity between the inside and the outside of the glass which does not indicate a fault and does not compromise the normal operation of lighting devices. The mist disappears quickly when the lights are turned on, starting from the centre of the diffuser, extending progressively towards the edges.

## TYPES OF BULBS

The car has the following bulbs:

**All-glass bulb:** (type A) these are press-fitted. Pull to extract.

---

**Bayonet bulb:** (type B) to remove this type of bulb from its holder, press the bulb and turn it anticlockwise.

---

**Cylindrical bulbs:** (type C): release them from their contacts to remove.

---

**Halogen bulbs:** (type D) release the fastening clip from the corresponding seat to remove the bulb.

---

**Halogen bulbs:** (type E) release the fastening clip from the corresponding seat to remove the bulb.

---

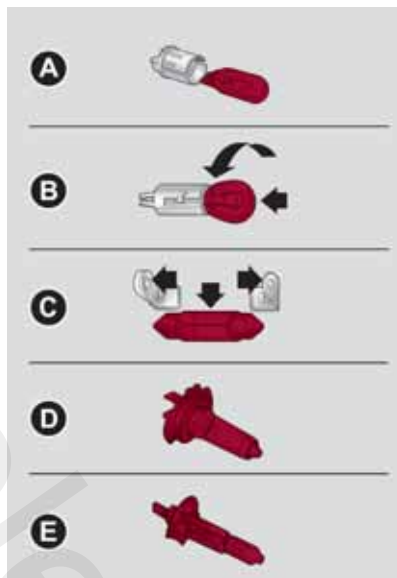

ABC

Light bulbs	Type	Power	Ref. Figure
Front side lights/Daytime running lights (DRL)	W21/5W	5/21W	A
Rear side lights	LED	-	-
Dipped headlights	H7	55W	D
Main beams	H1	55W	D
Front direction indicators	24W module	24W	B
Rear direction indicators	P21W	21W	B
Side direction indicators	WY5W	5W	A
Stop	LED	-	-
3rd brake light	LED	-	-
Number plate	W5W	5W	A
Fog lights	H1	55W	E
Rear fog light	P21W	21W	B
Reverse	P21W	21W	B
Front ceiling light	C10W	10W	C
Luggage compartment light	W5W	5W	A
Glove compartment light	C5W	5W	C
Puddle lights (where provided)	W5W	5W	A



### IMPORTANT

**27)** Halogen bulbs must be handled holding the metallic part only. Touching the transparent part of the bulb with your fingers may reduce the intensity of the emitted light and even reduce the lifespan of the bulb. In the event of accidental contact, wipe the bulb with a cloth moistened with alcohol and let the bulb dry.



## WARNING

**109)** Modifications or repairs to the electric system that are not carried out properly or do not take the system technical specifications into account can cause malfunctions leading to the risk of fire.

**110)** Halogen bulbs contain pressurised gas, in the case of breakage they may burst causing glass fragments to be projected outwards.

**111)** Due to the high power supply voltage, gas discharge bulbs (Bi-Xenon) should only be replaced by specialised personnel: danger of death! Contact an Alfa Romeo Dealership.



ABC

## REPLACING AN EXTERIOR BULB

### FRONT LIGHT CLUSTERS

These contain the bulbs for the side lights/daytime running lights (DRL), dipped beams, main beams and direction indicators. The bulbs are arranged as follows fig. 80:

- 1: Side lights/daytime running lights and main beam headlights
- 2: Dipped headlights
- 3: Direction indicators

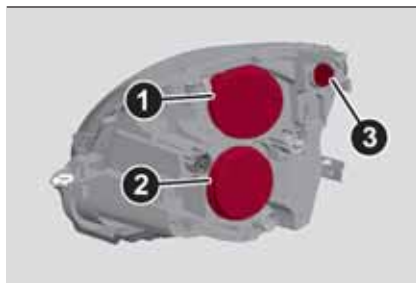

80

A0J0021C

### SIDE LIGHTS/DAYTIME RUNNING LIGHTS (DRL)

To replace the bulb, proceed as follows:

- remove the cover 1 of the front light cluster (see previous paragraph);
- Pull the bulb holder 2 fig. 81, extract the bulb and replace it;
- refit the bulb holder 2, locking it correctly;

- refit the cover 1 for the front light cluster.

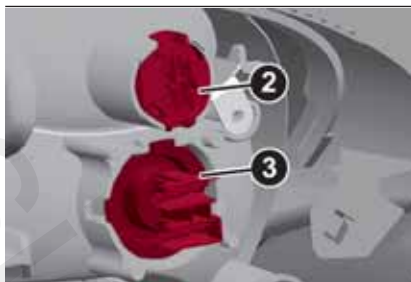

81

A0J0041C

### MAIN BEAM HEADLIGHTS

To replace the bulb, proceed as follows:

- remove the cover 1 of the front light cluster (see previous paragraph);
- Pull the bulb holder 3 fig. 82, extract the bulb and replace it;
- refit the bulb holder 3, locking it correctly;
- refit the cover 1 for the front light cluster.

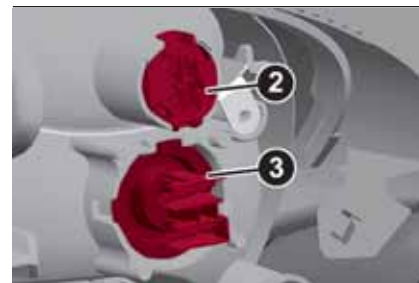

82

A0J0041C

### DIPPED HEADLIGHTS

(Versions with incandescent bulbs)

To replace the bulb, proceed as follows:

- remove the cover 2 of the front light cluster (see paragraph "Front light clusters);
- remove the bulb protective cover 1 fig. 83;
- extract the bulb and replace it;
- refit the bulb holder, locking it correctly;
- refit the cover 2 for the front light cluster.

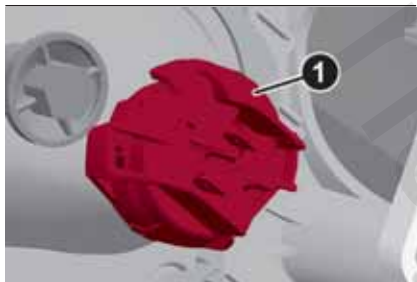

83

A0J0040C

## DIRECTION INDICATORS

### Front

To replace the bulb, take the key 1 fig. 84 (in the document wallet), insert it in the housing 2 and rotate the bulb holder anticlockwise. Then extract the bulb and replace it.

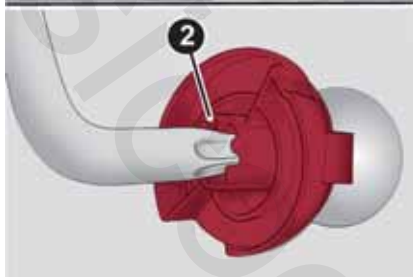
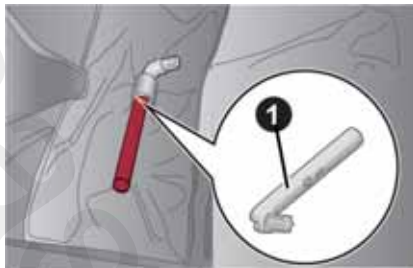

84

A0J0018C

### Side

To replace the bulb, proceed as follows:

- press the lens 1 fig. 85 to compress in the clip 2, then pull the cluster outwards;
- turn the bulb holder 3 anticlockwise, extract the bulb and replace it;
- refit the bulb holder 3 in the lens and turn it clockwise;
- refit the cluster making sure that the internal clip 2 clicks into position.

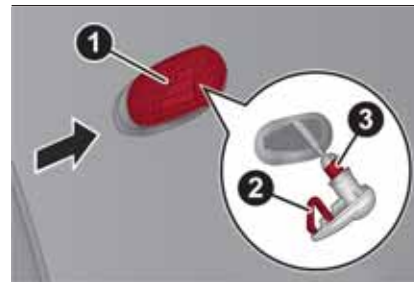

85

A0J0042C

## FRONT FOG LIGHTS

(where provided)

For replacing these bulbs, contact an Alfa Romeo Dealership.

## REAR LIGHT CLUSTERS

To access the light cluster, move the luggage compartment side trim (see fig. 86). The rear light cluster contains the bulbs for side lights, direction indicators and brake lights.



86

A0J0043C



ABC

### Direction indicators

To replace the bulb, lift the luggage compartment side trim, turn bulb-holder 1 fig. 86 and replace the bulb.

### Side lights / brake lights

These are LEDs. For the replacement, contact an Alfa Romeo Dealership.

### REAR FOG LIGHT/REVERSING LIGHT

To replace the rear fog light bulb 1 fig. 87 or the reversing light bulb 2, contact an Alfa Romeo Dealership.

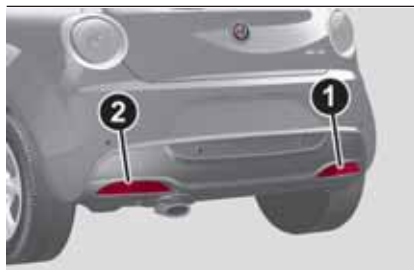

87

A0J0044C

### THIRD BRAKE LIGHTS

These are located in the tailgate and are LED lights. For the replacement, contact an Alfa Romeo Dealership.



88

A0J0046C

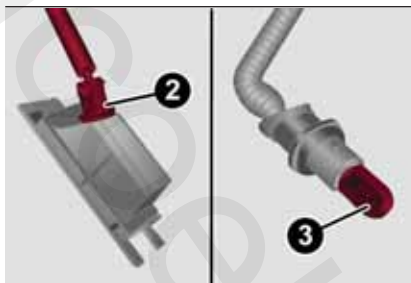

89

A0J0045C

### NUMBER PLATE LIGHTS

To replace the bulbs, proceed as follows:

- remove the number plate light units 1
- turn the bulb holder 2 fig. 89 clockwise, extract the bulb 3 and replace it.

## REPLACING FUSES

### GENERAL INFORMATION



112) 113) 114) 115) 116)

28)

Fuses protect the electrical system: they intervene (blow) in the event of a failure or improper action on the system.

### VERSIONS WITH "ALFA TCT" AUTOMATIC TRANSMISSION (where provided)

The Alfa TCT transmission components are protected by specific fuses. Contact an Alfa Romeo Dealership if a fuse needs replacing.

### VERSIONS WITH LPG SYSTEM (where provided)

The LPG system components are protected by specific fuses. Contact an Alfa Romeo Dealership if a fuse needs replacing.

### FUSEBOXES

Fuses are grouped together in fuseboxes located in the engine compartment, on the dashboard and inside the boot.

### Engine compartment junction box

29)

This is located next to the battery fig. 91: to access the fuses, undo screws 1 fig. 90 and remove cover 2.



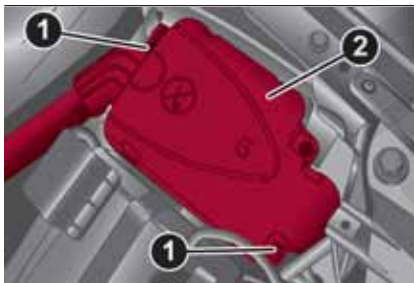

90

A0J0126C

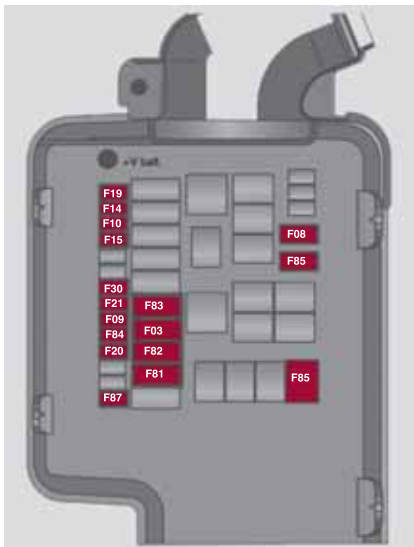

91

A0J0417C

The number identifying the electrical

component corresponding to each fuse is shown on the back of the cover. After replacing the fuse, make sure you close cover 2 on the fuse box.

### Dashboard fuse box

To access the fuses fig. 93 lower the flap 1 fig. 92, with a hand hold the cover 2 in the area indicated in figure and remove it operating in the sense indicated by the arrow, in order to disengage internal retainers 3 first, and then the tabs 4.

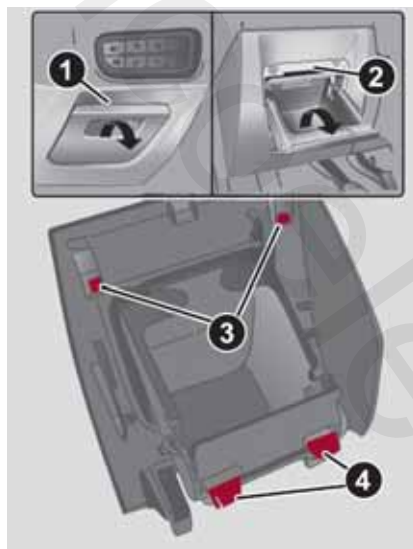

92

A0J0334C

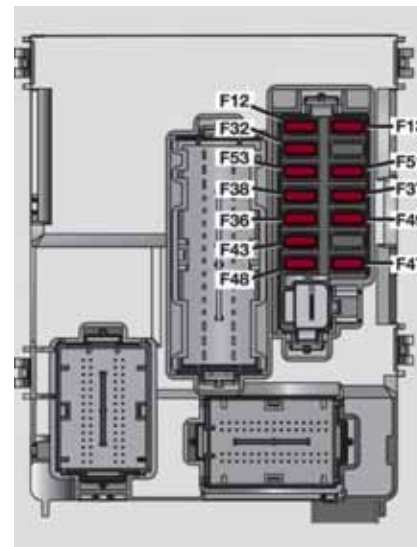

93

A0J0205C



ABC

**Luggage compartment fuse box**

To access the fuse box fig. 95 (located on the left side of the luggage compartment), open the relevant inspection lid as illustrated in figure fig. 94.

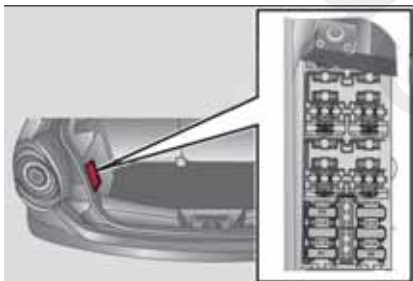

94

A0J0264C

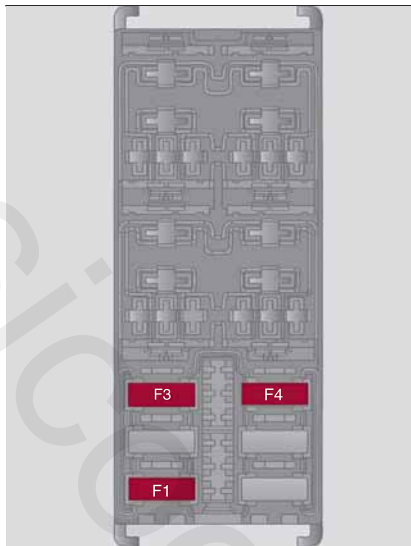

95

A0J0175C

**Engine compartment junction box**  
**fig. 91**

DEVICE PROTECTED	FUSE	AMPERE
Ignition device	F03	20
Passenger compartment fan	F08	40
Additional heater (Turbo TwinAir and 1.3 JTD <sub>M-2</sub> versions)	F09	5
Two-tone horn	F10	15
Main beam headlights	F14	15
Additional heater (PTC 1)	F15	30
Air conditioning compressor	F19	7.5
Heated rear windscreen, demisting system	F20	30
Electric fuel pump in tank	F21	15
Front fog lights	F30	15
Additional heater (PTC2)	F81	60
Additional heater (PTC1)	F82	50
Additional heater (PTC2)	F82	40
Free	F83	-
Hi-Fi sound system (control units, Bassbox speaker) mechanical gearbox setup	F84	20
Power socket on tunnel	F85	15
Electric door mirror demisters / Demisters on windscreen jets / Relay switch coil for heated windscreen	F87	7.5



ABC

## Dashboard fuse box fig. 93

DEVICE PROTECTED	FUSE	AMPERE
Free	F12	-
Headlamp alignment corrector	F13	5
INT/A Engine compartment control unit relays	F31	5
EOBD diagnosis plug supply / <b>Uconnect™</b> / Alarm buzz / Alarm volumetric sensors / Electrofan / TPMS system / Electric mirror controls / Climate control system controls	F36	15
Brake light switch (NA) / Instrument panel node / Headlight alignment corrector	F37	5
Doors and luggage compartment central locking	F38	15
Windscreen/rear window washer pump	F43	20
Electric window (driver side)	F47	20
Electric window (passenger side)	F48	20
Parking sensors / Control lighting / Electro-chrome mirror / Rain/dusk sensor / Sun roof / TPMS system / Cigar lighter lighting / SBR system panel	F49	5
Climate control system controls / Radio system configuration / <b>Bluetooth®</b> / Brake light switch (NC) / Clutch switch / Reverse gear switch / Airflow meter (Diesel versions) / Water in diesel filter sensor (Diesel versions)	F51	5
Instrument panel node	F53	5

## Luggage compartment fuse box fig. 95

DEVICE PROTECTED	FUSE	AMPERE
Electric roof opening system	F1	20
Luggage compartment power socket	F3	15
Front seat heating	F6	15



### IMPORTANT

**28)** Never replace a fuse with metal wires or anything else.

**29)** If it is necessary to wash the engine compartment, take care not to directly hit the fuse box and the window wiper motors with the water jet.



### WARNING

**112)** If a fuse blows again, contact an Alfa Romeo Dealership.

**113)** Never replace a fuse with another with a higher amp rating; DANGER OF FIRE.

**114)** If a general protective fuse (MAXI-FUSE, MEGA-FUSE, MIDI-FUSE) blows, contact an Alfa Romeo Dealership.

**115)** Before replacing a fuse, make sure that the ignition device is at STOP, that the key, if mechanical, has been removed and that all devices are switched off and/or disconnected.

**116)** Contact an Alfa Romeo Dealership if a safety system (airbags, brakes), transmission system (engine, gearbox) or steering system general protection fuse blows.



ABC

## CHANGING A WHEEL

### JACK

⚠ 117) 118) 119) 120) 121) 122)

⚠ 30) 31)

Please note that:

- the jack weight is 1.76 kg;
- the jack requires no adjustment;
- the jack cannot be repaired and in the event of a fault it must be replaced by another genuine one;
- no tool other than its cranking device may be fitted on the jack.

### Jack maintenance

- prevent any dirt from depositing on the "worm screw";
- keep the "worm screw" lubricated;
- never modify the jack.

### Conditions in which not to use the jack

- temperature below -40°C
- on sandy or muddy ground
- on uneven ground
- on steep roads
- in extreme weather conditions: thunderstorms, typhoons, hurricanes, blizzards, storms, etc.
- in direct contact with the engine or for repairs under the vehicle
- on boats.

### Wheel replacement procedure

To change a wheel, proceed as follows:

- stop the car in a position that is not dangerous for oncoming traffic where you can change the wheel safely. The ground must be flat and sufficiently compact;
- switch off the engine, pull up the handbrake and engage the 1<sup>st</sup> gear or reverse. Wear the reflective safety jacket (compulsory by law) before getting out of the vehicle;
- open the luggage compartment, lift the mat using the tab provided 1 fig. 96;



96

A0J0104C

- unscrew locking device 1 fig. 97, take toolbox 2 and bring it next to the wheel to replace. Then take the space-saver wheel 3;

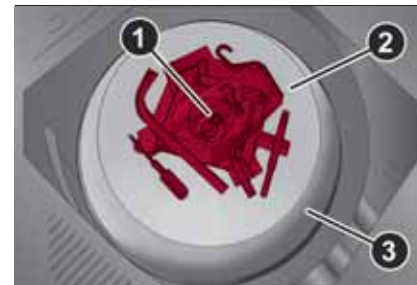

97

A0J0105C

- for versions with steel rims:** insert the screwdriver in the opening 1 fig. 98 in order to trigger the hub cap retaining clip 2;
- for versions with alloy rims:** shake the car to facilitate detachment of the rim from the wheel hub. Some versions may be fitted with alloy wheels with a hub cap fig. 99. To remove the hub cap, insert the screwdriver into housings 1 in order to access the fixing bolts. Replace the wheel as described previously;

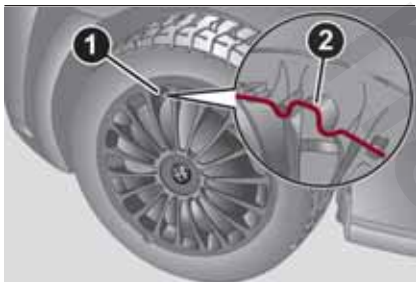

98

A0J0236C

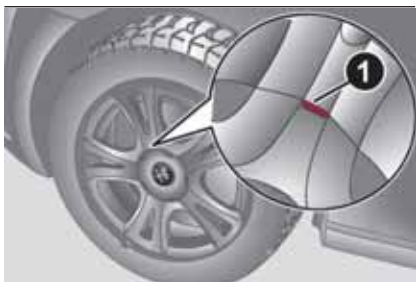

99

A0J0238C

- take the wrench 1 fig. 100 and loosen the fixing bolts by about one turn;
- position the jack under the car, near the wheel to be changed. On versions where this is fitted, be careful not to damage the plastic aerodynamic guard;
- operate the device 1 fig. 101 so as to raise the jack, until the upper part 2 fig. 102 is correctly inserted in the side member 3 at the point indicated by the arrow ▽;

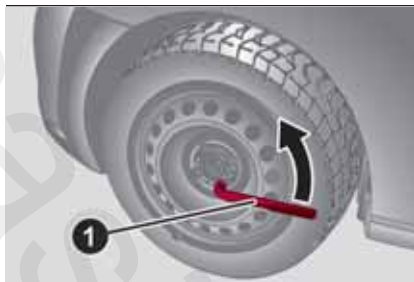

100

A0J0106C



101

A0J0062C

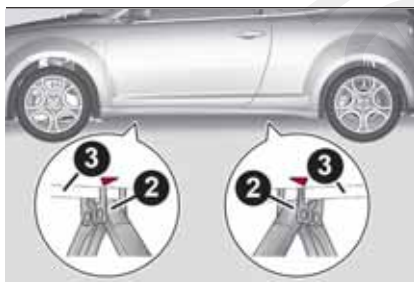

102

A0J0061C

- alert any bystander that the vehicle is about to be raised; all persons should be kept away from the vehicle and nobody must touch it until it has been lowered;
- fit handle 4 fig. 101 into the housing in device 1, operate the jack and raise the vehicle until the wheel is a few centimetres from the ground;
- make sure the contact surfaces between space-saver wheel and hub are clean so that the fastening bolts will not come loose;
- fit the space-saver wheel by inserting the first bolt for two threads into the hole closest to the valve;
- take the wrench 1 fig. 100 and fully tighten the fixing bolts;
- operate the jack handle 4 fig. 101 to lower the car. Then extract the jack;
- use the wrench 1 provided to fully tighten the bolts in a criss-cross fashion as per the numerical sequence illustrated in fig. 103;
- when replacing an alloy wheel it is advisable to place it upside down, with the aesthetic part facing upwards.



ABC

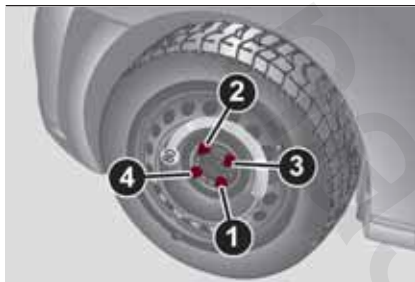

103

A0J0271C

Restore the standard wheel as soon as possible, because, once placed in the associated compartment, the luggage compartment load platform is rendered uneven as the standard wheel is larger than the spare wheel.

**REMOVING THE SUBWOOFER (versions with Bose HI-FI)**  
(where provided)

**IMPORTANT** The following procedure only applies to vehicles equipped with Bose HI-FI systems with Subwoofer (where provided).

**Subwoofer and space-saver spare wheel**

On these versions the tools for replacing the wheel are found in a dedicated bag in the luggage compartment.

Proceed as follows to remove the subwoofer:

- open the luggage compartment, pull the tab located on the mat and lift this upwards;
- unscrew locking device 1 fig. 104, raise the Subwoofer and then remove connection cable 2 from the Velcro 3;
- rest the subwoofer at one side in the luggage compartment, remove the container and take out the space-saver wheel;
- replace the wheel operating according to previous indication (see “Wheel replacement procedure”).



104

A0J0180C

At the end of the operation:

- reposition the container (with the arrow pointing forwards) in its housing and place the subwoofer on top of it, taking care to arrange it according to the indications on the container fig. 105 so that the word “BOSE” is positioned in the right direction for reading;
- rest cable 2 fig. 104 on the Velcro 3 to

- avoid pinching it;
- screw in locking device 1, and finally lower the luggage compartment mat.



105

A0J0260C

**Subwoofer and “Fix&Go Automatic Kit”**

To find the Fix&Go Automatic Kit, proceed as follows:

- open the luggage compartment, pull the tab located on the mat and lift this upwards;
- take the Fix&Go Automatic Kit located on the left-hand side of the luggage compartment fig. 106;
- inflate the tyre (see paragraph entitled “Fix&Go Automatic Kit”).





106

A0J0239C

**WARNING**

**117)** The space-saver wheel is specific for your car. Do not use it on cars of different models. Do not use space-saver wheels of different models on your car. The space-saver wheel must only be used in the event of an emergency. Never use it for more than strictly necessary and never exceed 80 km/h. On the space-saver wheel there is an orange label, summarising the main warnings regarding space-saver wheel usage restrictions. Never remove or cover the label. Never apply any hub cap to the space-saver wheel.

**118)** Alert other drivers that the car is stationary in compliance with local regulations: hazard warning lights, warning triangle, etc. Any passengers on board should leave the car, especially if it is heavily laden. Passengers should stay away from on-coming traffic while the wheel is being changed. On hills or uneven roads, use chocks or appropriate objects to block the wheels of the vehicle.

**119)** The vehicle's driving characteristics will be modified with the space-saver wheel fitted. Avoid violent acceleration and braking, abrupt steering and fast cornering. The overall duration of the space-saver wheel is about 3000 km, after which the relevant tyre must be replaced with another one of the same type. Never install a traditional tyre on a rim designed to be used as a space-saver wheel. Have the wheel repaired and refitted as soon as possible. Using two or more space-saver wheels at the same time is forbidden. Do not apply grease to the bolt threads before fitting: they could come unscrewed.

**120)** The jack may be used to replace wheels only on the car that it comes with or other cars of the same model. Never use the jack for other purposes, such as lifting other vehicle models. Never use it for repair operations under the vehicle. Incorrect positioning of the jack may cause the vehicle to fall. Do not use the jack for loads higher than the one shown on its label. Never install snow chains on the space-saver wheel; if a front tyre (driving wheel) is punctured and you need to use snow chains, use a standard wheel from the rear axle and install the space-saver wheel on the rear axle. In this way, with two normal front drive wheels, it is possible to use snow chains.

**121)** Incorrectly fitting the wheel cap may cause it to fall off when the car is in motion. Never tamper with the inflation valve. Never introduce tools of any kind between rim and tyre. Regularly check the inflation pressure of the tyres and space-saver wheel (see chapter "Technical specifications").

**122)** The jack is a tool developed and designed only for changing a wheel, if a tyre gets punctured or damaged, on the vehicle with which it is supplied or on other vehicles of the same model. Any other use, e.g. to jack up other vehicle models or different things, is strictly prohibited. Never use for maintenance or repair activities under the car or to exchange the summer/winter wheels and vice versa. Never go under the raised vehicle. Should it be necessary to work under the vehicle, contact an Alfa Romeo Dealership. Incorrect positioning of the jack may cause the raised vehicle to fall: use only in the positions indicated. Do not use the jack for loads higher than the one shown on its label. Never start the engine with vehicle raised. If the vehicle is raised more than necessary, everything can become more unstable, with the risk of the vehicle dropping violently. Thus, lift the vehicle only as needed in order to access the spare wheel.



ABC

**IMPORTANT**

**30)** When turning the jack handle make sure that it can turn freely without scraping your hand against the ground. The moving components of the jack ("worm screw" and joints) can also cause injuries: avoid touching them. If you come into contact with lubricating grease, clean yourself thoroughly.

**31)** Contact an Alfa Romeo Dealership as soon as possible to have the correct tightening of the wheel bolts checked.

**"Fix&Go Automatic" KIT**

123)

32) 33)

This is located in the boot. The kit also contains a screwdriver and a tow hook.

The kit also contains:

- bottle 4 fig. 107 containing sealant and fitted with: filling tube 1 and adhesive label 3 with the wording "Max. 80 km/h" to be placed in a clearly visible position (e.g. on the dashboard) after repairing the tyre;
- compressor 2 complete with pressure gauge and connectors;
- an information leaflet, providing instructions for using the kit correctly. This booklet should be given to the persons charged with handling the tyre treated with this kit;
- a pair of gloves located in the side compartment of the compressor;
- adaptors for inflating different elements.

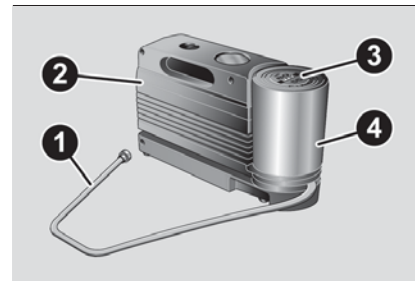

107

A0K0516C

**Versions with LPG system**

The car does not have a spare wheel but a tool box fig. 108 that contains the "Fix&Go Automatic" kit, the tow hook and a screwdriver.

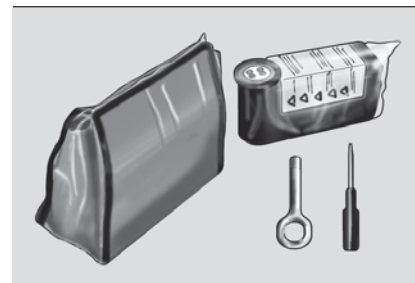

108

A0J0359C

**TYRE REPAIRING AND PRESSURE RESTORING PROCEDURE**

Proceed as follows:

- place the vehicle in a safe and suitable area, engaging the parking brake. Take

the kit from the specific compartment;  
❑ remove the adhesive label of speed 3 (see previous paragraph) and apply it in a visible position. Wear the protective gloves provided;

❑ remove the cap from the valve of the punctured tyre and connect and firmly tighten the transparent tube of the sealing fluid 1 fig. 109 and tighten nut 2 on the tyre valve;



109

A0K0518C

❑ make sure that the switch for the compressor is in position **0** (off), start the engine, open the rear hatch and insert the plug in the into the luggage compartment power socket or on central tunnel and start the engine. Switch on the compressor by turning the switch to position **I** (on);

❑ inflate the tyre to the pressure indicated in the "Wheels" paragraph in the "Technical data" chapter;

❑ if after five minutes pressure is not at least 1.8 bar/26 psi, turn off the compressor and disconnect it from the valve and power socket, replace the cap, then move the vehicle forwards by approx. ten metres in order to distribute the sealing fluid inside the tyre evenly. Stop the vehicle safely and repeat the operation above until the required pressure is reached;

❑ if after this operation you still cannot reach at least 1.8 bar/26 psi after 5 minutes from switching on the compressor, **THE TYRE IS TOO DAMAGED TO BE REPAIRED**. Remove and place the kit in the specific compartment and contact an Alfa Romeo Dealership;

❑ if the required pressure is reached, restart driving. Do not exceed 80 km/h. Avoid sudden acceleration or braking. After driving for about 8 km / 5 miles, place the vehicle in a safe and suitable area, engaging the parking brake. Pick up the kit, ensure the on-off button is in **0** position, insert the electrical connector in the vehicle 12V socket. Remove the cap from the valve of repaired tyre, disconnect and pull out the black inflation tube, connect it to the valve and lock it with the lever. Check the tyre pressure on the pressure gauge.

❑ if the pressure is lower than 1.8 bar / 26 psi, the **TYRE IS TOO DAMAGED AND CANNOT BE REPAIRED**. Remove and place the kit in the specific compartment and contact an Alfa Romeo Dealership;

❑ if the pressure indicated is equal to or higher than 1.8 bar/26 psi, switch on the compressor and inflate to the required pressure. Disconnect and replace the kit in the specific compartment. Drive carefully to the nearest Alfa Romeo Dealership as soon as possible.

### **CHECKING AND RESTORING TYRE PRESSURE**

The compressor can also be used to check and, if necessary, restore the tyre pressure.

Disconnect and pull out the black inflation tube 1 fig. 110, connect and to the tyre valve and lock in position with the lever.

With the same procedure it is possible to inflate bicycle tyres and balloons. The kit should be used by adults and cannot be used by children.



ABC



110

AOK0521C

### CARTRIDGE REPLACEMENT

Only use Fix&Go original cartridges which can be purchased at an Alfa Romeo Dealership.

To remove the cartridge, disengage the coupling of the black inflation tube, rotate the cartridge anticlockwise and then lift it. Insert the new cartridge, rotate it clockwise to its end of travel, insert the coupling of the black inflation tube blocking it with the lever and then rewind the transparent tube into its compartment on the compressor.



### IMPORTANT

**32)** Show the package and the label to the personnel charged with handling the tyre treated with the tyre repair kit.

**33)** Fix&Go provides a temporary repair, therefore the tyre must be examined and repaired by a specialist as soon as possible. The sealing fluid is effective at temperatures between  $-40^{\circ}\text{C}$  and  $+50^{\circ}\text{C}$ . It is possible to repair tyres which have been damaged on tread up to a diameter of 4mm; however, tyres damaged on their side cannot be repaired. Before using Fix&Go kit, ensure that the tyre isn't excessively damaged and that the rim is in good condition, otherwise do not use it and contact an Alfa Romeo Dealership. Do not remove foreign bodies from the tyre. Do not let the compressor turned on for more than 20 consecutive minutes - overheating hazard.



### WARNING

**123)** The information required by the applicable regulation is indicated on the Fix&Go kit package label. Compliance with the indications on the label is an essential condition to ensure the safety and the effectiveness of the Fix&Go kit. Carefully read the label before use, avoid improper use. Fix&Go is subject to expiration and must be replaced periodically. The kit should be used by adults and cannot be used by children.

## JUMP STARTING

### STARTING THE ENGINE

If the  icon stays on with steady light on the instrument panel display, immediately contact an Alfa Romeo Dealership.

### JUMP STARTING

 124)

 34) 35)

If the battery is flat, start the engine using an auxiliary battery with the same capacity or a little higher than the flat one.

Proceed as follows to start the vehicle fig. 111:

- connect the positive terminals (+ mark near the terminal) of the two batteries using a suitable lead;
- with a second lead, connect the negative terminal (-) of the auxiliary battery to an earth point  on the engine or the gearbox of the car to be started;
- start the engine; when the engine has been started, remove the leads reversing the order above.

If after a few attempts the engine does not start, contact the Alfa Romeo Dealership.

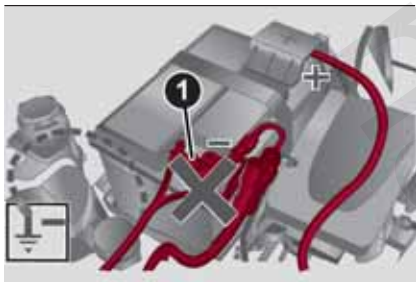

111

A0J0392C

## JUMP STARTING

(versions with Start&Stop system)

### 125)

When jump starting, never connect the negative lead (-) of the auxiliary battery to the negative pole 1 fig. 111 of the car battery, but rather to an engine/gearbox earth point.

## BUMP STARTING

Never, under any circumstances, jump start the engine by pushing, towing or coasting downhill.



## IMPORTANT

**34)** Never connect the negative terminals of the two batteries directly! If the auxiliary battery is installed on another car, prevent accidental contact between metallic parts of the two cars.

**35)** Never use a fast battery-charger to start the engine as this could damage the electronic systems of your vehicle, particularly the ignition and engine fuel supply control units.



## WARNING

**124)** This starting procedure must be performed by expert personnel because incorrect actions could cause electrical discharge of considerable intensity. Furthermore, battery fluid is poisonous and corrosive: avoid contact with skin and eyes. Keep naked flames and lighted cigarettes away from the battery and do not cause sparks.

**125)** Before opening the bonnet, make sure that the engine is off and that the ignition key is in the STOP position. Please follow the instructions on the decal near the front crossmember. We recommend that you remove the key from the ignition if other people remain in the vehicle. The vehicle should always be left after the key has been removed or turned to the STOP position. During refuelling, make sure that the engine is off (and that the ignition key is in the STOP position).

## FUEL CUT-OFF SYSTEM

### Operation

This intervenes in the case of an impact causing:

- the fuel supply cut-off with the engine consequently switching off;
- the automatic unlocking of the doors;
- the switching on of the interior lights.

The intervention of the system is indicated by a message shown on the display.

Carefully check the vehicle for fuel leaks, for instance in the engine compartment, under the vehicle or near the tank area.

### 126)

After a collision, turn the ignition key to STOP to prevent the battery from running down.

To restore the correct operation of the car, proceed as follows:

- turn the ignition key to the MAR position;
- activate the right direction indicator;
- deactivate the right direction indicator;
- activate the left direction indicator;
- deactivate the left direction indicator;
- activate the right direction indicator;
- deactivate the right direction indicator;
- activate the left direction indicator;
- deactivate the left direction indicator;



ABC

- ❑ ignition key turned to the OFF position;
- ❑ turn the ignition key to the MAR-ON position.

### Versions with LPG system

In case of impact, petrol supply is immediately cut-off, the LPG safety valves are closed and the injection is interrupted, switching off the engine.



### WARNING

**126)** If, after an impact, you smell fuel or notice leaks from the fuel system, do not reactivate the system to avoid the risk of fire.

## ALFA TCT TRANSMISSION - KEY REMOVAL



The ignition key can be removed only if the gear lever is in position P (Park).  
If the battery is flat and the ignition key is engaged, the latter is locked in position.

To remove the key manually, proceed as follows:

- ❑ apply the handbrake;
- ❑ release the steering wheel position adjustment lever 1 fig. 112 and pull the steering wheel towards you until it is in the end of travel position;
- ❑ using the Allen key fig. 113 provided, unscrew the top screws 2 fig. 114 securing cover 3;
- ❑ remove the lower steering wheel cover 4 fig. 115 by releasing it from its housing;



112

A0J0342C



113

A0K0713C

- ❑ pull tab 5 fig. 116 downwards using one hand and with the other one remove the key, sliding it outwards;
- ❑ once the key has been removed, refit lower cover, make sure it locks correctly.



114

A0J0571C

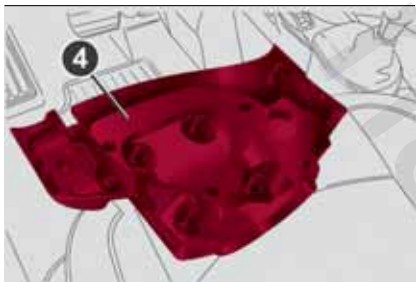

115

A0J0570C

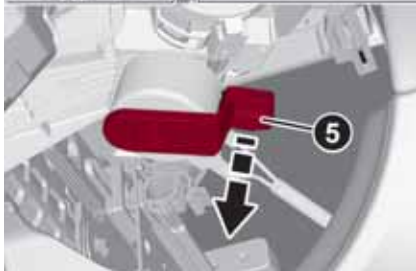
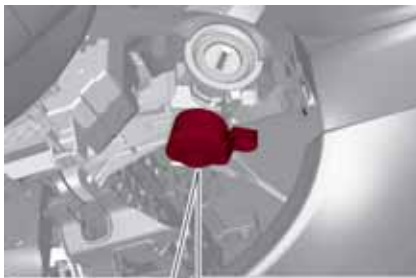

116

A0J0574C



## IMPORTANT

**36)** It is advisable to contact an Alfa Romeo Dealership to have the refitting procedure carried out. If you would like to proceed autonomously, special attention must be paid to the correct coupling of the retaining clips. Otherwise, noise might be heard due to an incorrect fastening of the lower cover with the upper cover.

## TOWING THE VEHICLE

The tow hook provided with the car is located in the tool box in the luggage compartment.

### ATTACHING THE TOW RING

 127) 128) 129)

#### Towing from the front

Remove cap 1 fig. 117 from its housing using a screwdriver or similar tool in the lower slot. Take care not to damage the paint. Take tow hook 2 from its housing in the tool support and screw it in fully on the threaded pin.

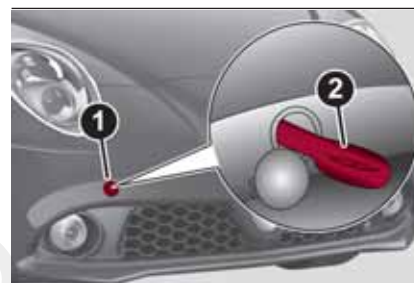

117

A0J0038C

#### Towing from the rear

Remove cap 1 fig. 118 from its housing using a screwdriver or similar tool in the upper slot. Take care not to damage the paint. Take tow hook 2 from its housing in the tool support and screw it in fully on the threaded pin.



ABC

**“VELOCE” versions:** remove cap 1 by pressing on the upper part, take tow hook 2 from its housing in the tool support and screw it in fully on the threaded pin.

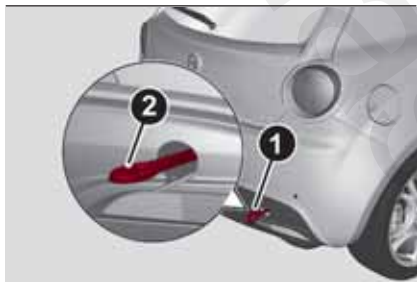

118

A0J0039C

**WARNING**

**127)** For versions with key without remote control, before towing, turn the ignition key to MAR and then to STOP without removing it. The steering column will automatically lock when the key is removed and the wheels cannot be steered. Also check that the gearbox is in neutral (on versions equipped with automatic transmission, check that the gear lever is in N position). For versions with electronic key, move the ignition device to MAR and then to STOP, without opening the door.

**128)** The brake servo and the electromechanical power steering will not work while the vehicle is being towed. You will therefore need to apply more force on the brake pedal and steering wheel. Do not use flexible ropes when towing, and avoid jerky movements. During towing, make sure that the trailer hitch does not damage any components it is touching. When towing the car, you must comply with all specific traffic regulations and adopt an appropriate driving behaviour. Do not start the engine while towing the car. Before tightening the ring, clean the threaded housing thoroughly. Make sure that the ring is fully screwed into the housing before towing the car.

**129)** The front and rear tow hooks should be used only for emergencies on the road. You are allowed to tow the vehicle for short distances using an appropriate device in accordance with the highway code (a rigid bar), to move the vehicle on the road in readiness for towing or transport via a breakdown vehicle. Tow hooks **MUST NOT** be used to tow vehicles off the road or where there are obstacles and/or for towing operations using cables or other non-rigid devices. In compliance with the above conditions, towing must take place with the two vehicles (one towing, the other towed) aligned as much as possible along the same centre line.





## SERVICING AND MAINTENANCE

SCHEDULED SERVICING . . . . .	128
SCHEDULED MAINTENANCE PLAN . . . . .	129
PERIODIC CHECKS . . . . .	136
DEMANDING USE OF THE CAR . . . . .	136
CHECKING LEVELS . . . . .	137
BATTERY RECHARGING . . . . .	143
WINDSCREEN / REAR WINDOW WIPERS . . . . .	144
BATTERY . . . . .	146
LIFTING THE VEHICLE . . . . .	147
BODYWORK . . . . .	147
INTERIOR . . . . .	149

Correct maintenance permits the performance of the car to be maintained over time, as well as limited running costs and safeguarding the efficiency of the safety systems.  
This chapter explains how.

## SCHEDULED SERVICING

Correct servicing is crucial for guaranteeing a long life for the vehicle under the best conditions.

For this reason, Alfa Romeo has planned a series of checks and services at fixed distance intervals and, where provided, at fixed time intervals, as described in the Scheduled Servicing Plan.

Regardless of the above, it is always necessary to carefully follow the instructions in the Scheduled Servicing Plan (e.g. periodically check level of liquids, tyre pressure, etc.).

Scheduled Servicing is offered by all Alfa Romeo Dealerships according to fixed time or kilometres/miles intervals. If, during each operation, in addition to the ones scheduled, the need arises for further replacements or repairs, these may be carried out with the owner's explicit agreement only. If your vehicle is used frequently for towing, the interval between one service operation and the next should be reduced.

## IMPORTANT NOTES

Scheduled Servicing interventions are set out by the Manufacturer. Failure to have them carried out may invalidate the warranty.

It is advisable to inform the Alfa Romeo Dealership of any small operating irregularities without waiting for the next service.

## SCHEDULED MAINTENANCE PLAN

### PETROL VERSIONS

The checks listed in the Scheduled Servicing Plan, after reaching 120,000 km/8 years, must be cyclically repeated starting from the first interval, thus following the same intervals as before.

Thousands of miles	9	18	27	36	45	54	63	72	81	90
Thousands of kilometres	15	30	45	60	75	90	105	120	135	150
Years	1	2	3	4	5	6	7	8	9	10
Check tyre condition/wear and adjust pressure, if necessary. Check "Fix&Go Automatic" kit recharge condition/expiry date	•	•	•	•	•	•	•	•	•	•
Check operation of lighting system (headlights, direction indicators, hazard warning lights, boot, passenger compartment, glove compartment, instrument panel warning lights, etc.)	•	•	•	•	•	•	•	•	•	•
Check and, if necessary, top up fluid levels (1)	•	•	•	•	•	•	•	•	•	•
Check exhaust emissions/smokiness	•	•	•	•	•	•	•	•	•	•
Use the diagnosis socket to check supply/engine management system operation, emissions and, where present, engine oil degradation	•	•	•	•	•	•	•	•	•	•

(1) Always only use the liquids shown in the handbook for topping up after having checked that the system is not damaged.



ABC

Thousands of miles	9	18	27	36	45	54	63	72	81	90
Thousands of kilometres	15	30	45	60	75	90	105	120	135	150
Years	1	2	3	4	5	6	7	8	9	10
Visually inspect conditions of: exterior bodywork, underbody protection, pipes and hoses (exhaust, fuel system, brakes), rubber elements (gaiters, sleeves, bushes, etc.)	•		•		•		•		•	
Visually inspect condition of: LPG pipes and connectors, LPG tank fastening (1.4 Turbo Petrol/LPG 120 HP version)		•		•		•		•		•
Check windscreen/rear window wiper blade position/wear	•		•		•		•		•	
Check operation of the windscreen wiper/washer system and adjust jets, if necessary	•		•		•		•		•	
Check cleanliness of bonnet and luggage compartment locks, cleanliness and lubrication of linkage		•		•		•		•		•
Check handbrake lever travel and adjust, if necessary		•		•		•		•		•
Visually inspect condition and wear of front and rear disc brake pads	•	•	•	•	•	•	•	•	•	•
Visually inspect conditions of toothed timing drive belt (Turbo TwinAir versions excluded)				•						

Thousands of miles	9	18	27	36	45	54	63	72	81	90
Thousands of kilometres	15	30	45	60	75	90	105	120	135	150
Years	1	2	3	4	5	6	7	8	9	10
Visually inspect condition of the accessory drive belt(s)				●						
Check and, if necessary, top up Alfa TCT oil level (where provided)(2)		●		●		●		●		●
Change engine oil and replace oil filter(3)	○	●	○	●	○	●	○	●	○	●
Spark plug replacement(4)		●		●		●		●		●
Replace accessory drive belt/s	(5)									
Replacement of toothed timing drive belt (excluding TwinAir Turbo versions)	(5)									
Replace air cleaner cartridge (6)		●		●		●		●		●

(2) Check to be carried out every year for cars on the road in countries with particularly severe climates (cold countries).

(3) If the car's annual mileage is less than 10,000 km, the engine oil and filter must be replaced every year.

(4) For 1.4 Turbo MultiAir versions, to guarantee correct operation and prevent serious damage to the engine, it is essential to proceed as follows: only use spark plugs specifically certified for these engines; all spark plugs should be of the same type and brand (see the "Engine" paragraph in the "Technical specifications" chapter); strictly comply with the spark plugs replacement intervals in the Scheduled Servicing Plan. It is advisable to contact an Alfa Romeo Dealership for spark plug replacement.

(5) Areas that are not dusty: recommended maximum mileage 120,000 km. The belt must be replaced every 6 years, regardless of distance travelled. Dusty areas and/or demanding use of the car (cold climates, town use, long periods of idling): advised maximum mileage 60,000 km. The belt must be replaced every 4 years, regardless of distance travelled.

(6) If the vehicle is used in dusty areas, this cleaner must be replaced every 15,000 km.



ABC

Thousands of miles	9	18	27	36	45	54	63	72	81	90
Thousands of kilometres	15	30	45	60	75	90	105	120	135	150
Years	1	2	3	4	5	6	7	8	9	10
Replace filter inside the pressure regulator (1.4 Turbo Petrol/LPG 120 HP version)						●				
Replace paper filter (LPG in gaseous state) (1.4 Turbo Petrol/LPG 120 HP version)		●		●		●		●		●
Change the brake fluid	(7)									
Replace the passenger compartment cleaner (6) (o) (●)	○	●	○	●	○	●	○	●	○	●

(7) The brake fluid replacement has to be done every 2 years, irrespective of the mileage.

(6) If the vehicle is used in dusty areas, this cleaner must be replaced every 15,000 km.

(o) Recommended operations

(●) Mandatory operations

## DIESEL VERSIONS

The checks listed in the Scheduled Servicing Plan, after reaching 120,000 km/6 years, must be cyclically repeated starting from the first interval, thus following the same intervals as before.

Thousands of miles	12	24	36	48	60	72	84	96	108	120
Thousands of kilometres	20	40	60	80	100	120	140	160	180	200
Years	1	2	3	4	5	6	7	8	9	10
Check tyre condition/wear and adjust pressure, if necessary. Check "Fix&Go Automatic" kit recharge condition/expiry date	•	•	•	•	•	•	•	•	•	•
Check operation of lighting system (headlights, direction indicators, hazard warning lights, boot, passenger compartment, glove compartment, instrument panel warning lights, etc.)	•	•	•	•	•	•	•	•	•	•
Check and, if necessary, top up fluid levels(1)	•	•	•	•	•	•	•	•	•	•
Check exhaust emissions/smokiness	•	•	•	•	•	•	•	•	•	•
Use the diagnosis socket to check supply/engine management system operation, emissions and, where present, engine oil degradation	•	•	•	•	•	•	•	•	•	•

(1) Always only use the liquids shown in the handbook for topping up after having checked that the system is not damaged.



ABC

Thousands of miles	12	24	36	48	60	72	84	96	108	120
Thousands of kilometres	20	40	60	80	100	120	140	160	180	200
Years	1	2	3	4	5	6	7	8	9	10
Visually inspect conditions of: exterior bodywork, underbody protection, pipes and hoses (exhaust, fuel system, brakes), rubber elements (gaiters, sleeves, bushes, etc.)	•		•		•		•		•	
Check windscreen/rear window wiper blade position/wear	•		•		•		•		•	
Check operation of the windscreen wiper/washer system and adjust jets, if necessary	•		•		•		•		•	
Check cleanliness of bonnet and luggage compartment locks, cleanliness and lubrication of linkage		•		•		•		•		•
Check handbrake lever travel and adjust, if necessary		•		•		•		•		•
Visually inspect condition and wear of front and rear disc brake pads	•	•	•	•	•	•	•	•	•	•
Visual inspect condition and check tension of accessory drive belt(s) (for versions without automatic tensioner only)		•						•		
Change engine oil and replace oil filter	(2)									

(2) The actual interval for changing engine oil and replacing the engine oil filter depends on the vehicle usage conditions and is signalled by the warning light or message in the instrument panel. In any case, it must never exceed 2 years. If the vehicle is mainly used in towns and cities, change the engine oil and filter every year.



Thousands of miles	12	24	36	48	60	72	84	96	108	120
Thousands of kilometres	20	40	60	80	100	120	140	160	180	200
Years	1	2	3	4	5	6	7	8	9	10
Replace accessory drive belt/s	(3)									
Replace fuel filter cartridge(4)			●			●			●	
Replace air cleaner cartridge(5)		●		●		●		●		●
Change the brake fluid	(6)									
Replace the passenger compartment cleaner(5) (o) (●)	○	●	○	●	○	●	○	●	○	●

(3) Areas that are not dusty: recommended maximum mileage 120,000 km. The belt must be replaced every 6 years, regardless of distance travelled.  
 Dusty areas and/or demanding use of the car (cold climates, town use, long periods of idling): advised maximum mileage 60,000 km. The belt must be replaced every 4 years, regardless of distance travelled.

(4) If the vehicle runs on fuel with quality below the relevant European specification, this filter must be replaced every 20,000 km

(5) If the vehicle is used in dusty areas, this cleaner must be replaced every 20,000 km.

(6) The brake fluid replacement has to be done every 2 years, irrespective of the mileage.

(o) Recommended operations

(●) Mandatory operations



ABC

## PERIODIC CHECKS

Every 1,000 km or before long trips check and, if necessary, top up:

- engine coolant, brake fluid and windscreen washer fluid level;
- tyre inflation pressure and condition;
- operation of lighting system (headlights, direction indicators, hazard warning lights, etc.);
- operation of screen wash/wipe system and positioning/wear of windscreen/rearscreen wiper blades

Every 3,000 km check and top up if required: engine oil level.

**IMPORTANT** To find out the correct oil quantity, always check using the dipstick. Carry out the check with the vehicle parked on level ground.

## DEMANDING USE OF THE CAR

If the vehicle is used mainly under one of the following conditions:

- towing a trailer or caravan;
- dusty roads;
- short, repeated journeys (less than 7-8 km) at sub-zero outside temperatures;
- engine often idling or driving long distances at low speeds or long periods of inactivity;

the following checks must be carried out more often than indicated in the Scheduled Servicing Plan:

- check front disc brake pad condition and wear;
- check cleanliness of bonnet and luggage compartment locks, cleanliness and lubrication of linkage;
- visually inspect condition of: engine, gearbox, transmission, pipes and hoses (exhaust - fuel system - brakes) and rubber elements (boots - sleeves - bushes - etc.);
- check battery charge and battery fluid level (electrolyte);
- visually inspect conditions of the accessory drive belts;

- check and, if necessary, change engine oil and replace oil filter;
- check and, if necessary, replace pollen filter;
- check and, if necessary, replace air cleaner.

## CHECKING LEVELS

⚠ 130) 131)

⚠ 37)

**Turbo TwinAir versions**

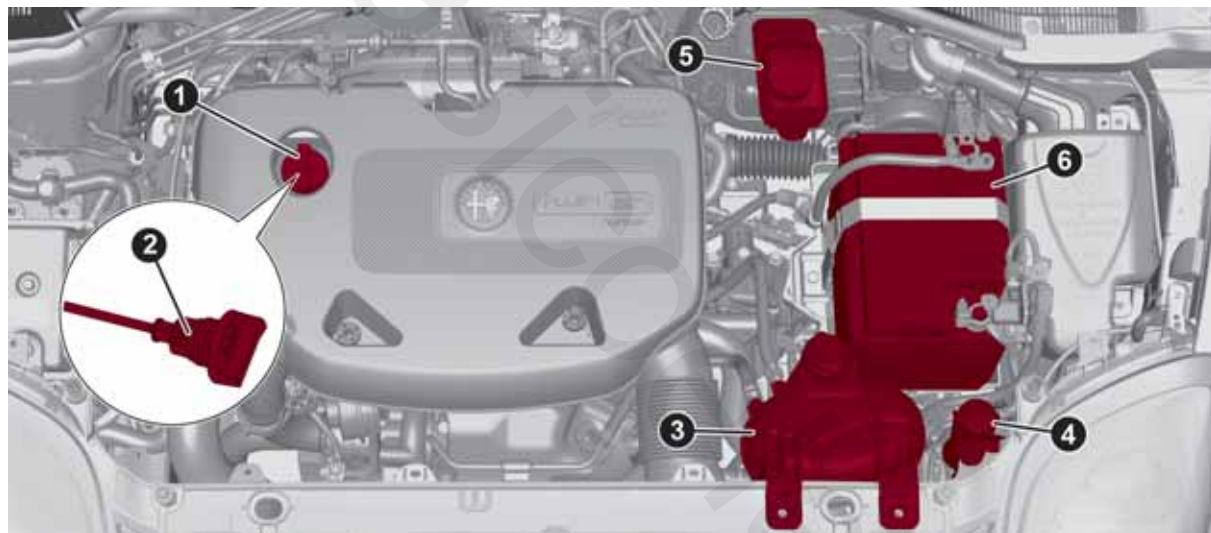

119

A0J0380C



ABC

### 1.4 Petrol versions

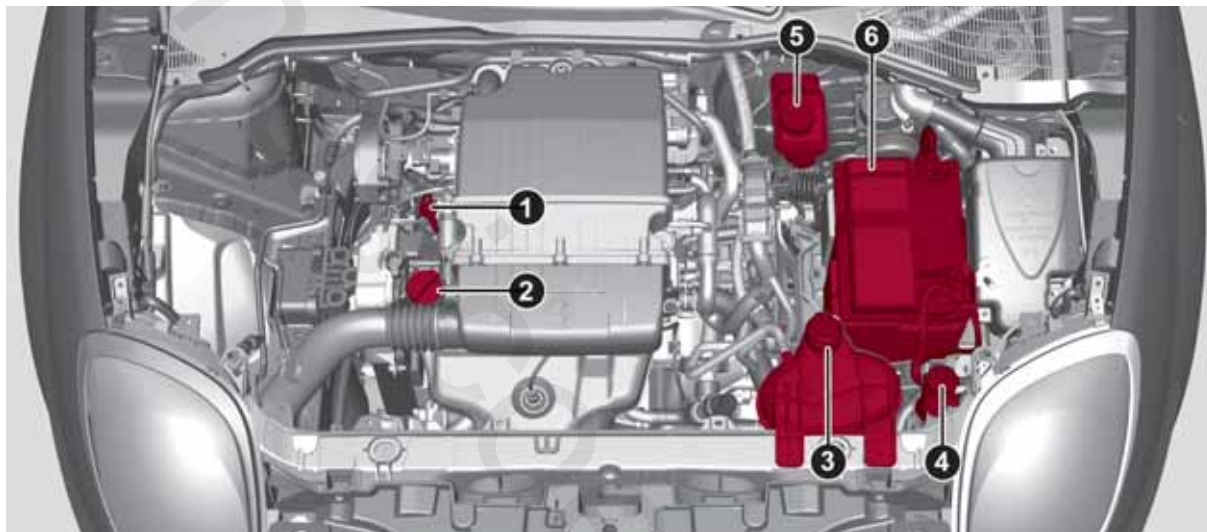

120

A0J0300C

## 1.4 Turbo Petrol/LPG versions

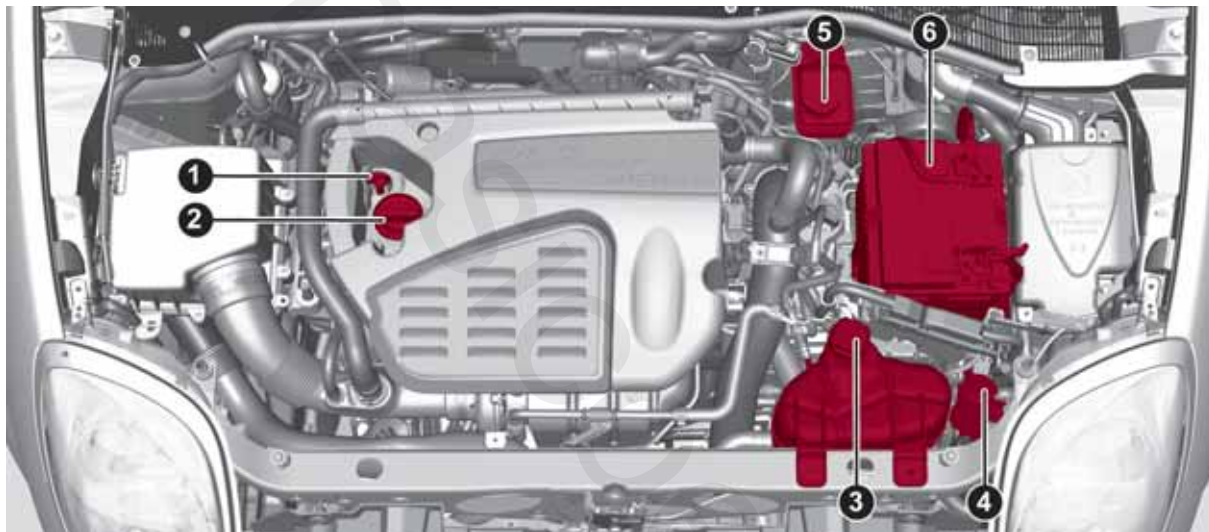

121

A0J0955C



ABC

### 1.4 Turbo MultiAir versions

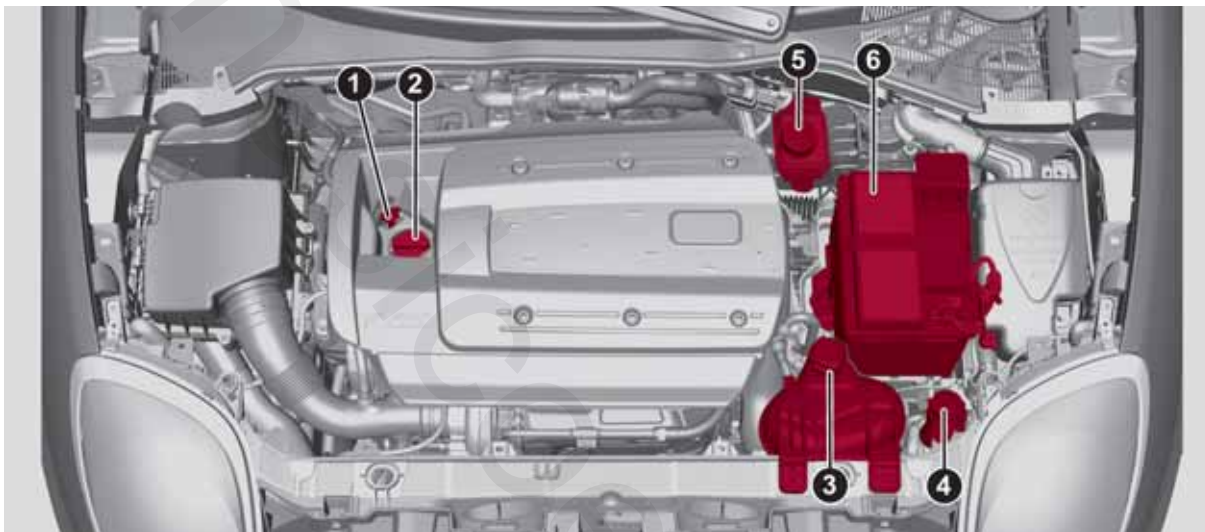

122

A0J0283C

### 1.3 JTD M-2 versions

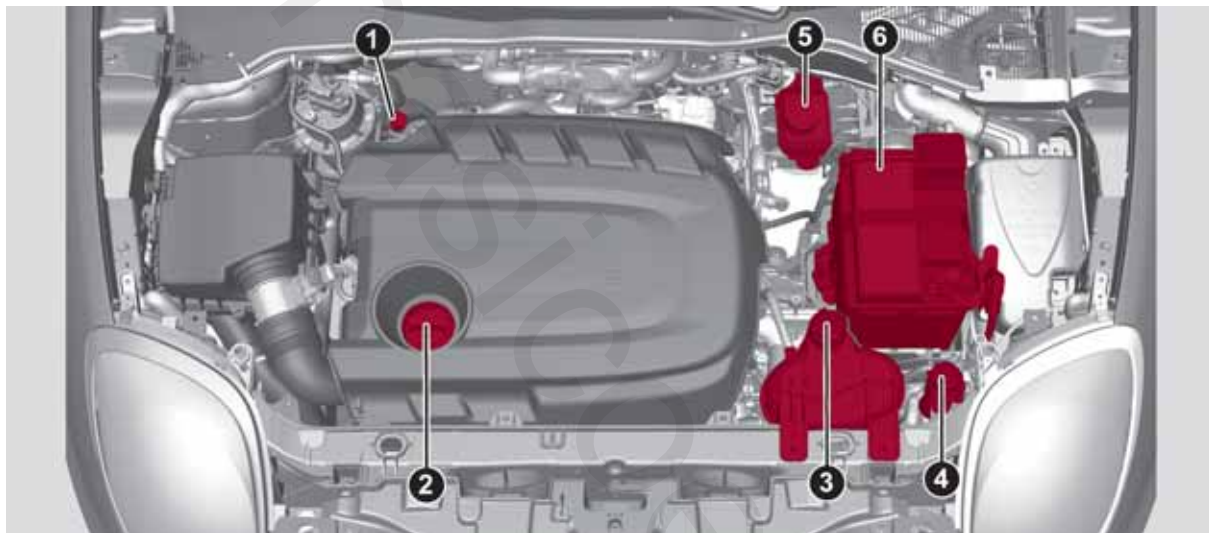

123

A0J0411C



ABC

**ENGINE OIL**

132)



38) 39)



2)

Check that the oil level is between the MIN and MAX references on the dipstick  
1. If the level of the oil is close to or below the MIN mark, add oil via the filler fitting  
2 until the MAX mark is reached.

**1.4 Petrol / 1.4 Turbo Petrol/LPG / 1.4 Turbo Multi Air / 1.3 JTD<sub>M-2</sub> versions: pull the engine oil dipstick 1, clean it with a lint-free cloth and insert it again. Extract it again and check that the level is between the MIN and MAX marks on the dipstick.**

**Turbo TwinAir versions:** engine oil dipstick 1 is integral with the cap 2. Unscrew the cap, clean the dipstick with a lint-free cloth, reinsert the dipstick and screw the cap back on. Unscrew the plug again and check that the engine oil level is between the MIN and MAX marks on the dipstick.

**Engine oil consumption**

The maximum engine oil consumption is usually 400 grams every 1000 km. When the car is new, the engine needs to be run in; therefore the engine oil consumption can only be considered stabilised after the first 5000 - 6000 km.

**ENGINE COOLANT FLUID**

132)



40)

If the level is too low, unscrew the cap 3 of reservoir and add the fluid described in the "Technical Specifications" chapter.

**WINDSCREEN / REAR WINDOW WASHING FLUID**

134) 135)

If the level is too low, raise the reservoir cap 4 and add the fluid described in the "Technical Specifications" chapter.

**BRAKE FLUID**

136) 137)



41)

Check that the fluid is at the max. level. If the fluid level in the reservoir is too low, undo the reservoir cap 5 and add the fluid described in the "Technical Specifications" chapter.

**ALFA TCT ACTIVATION SYSTEM OIL (where provided)**

3)

The transmission control oil level should only be checked at an Alfa Romeo Dealership.

**IMPORTANT**

**37)** Be careful not to confuse the various types of fluids while topping up: they are not compatible with each other! Topping up with an unsuitable fluid could severely damage your vehicle.

**38)** The oil level must never exceed the MAX reference.

**39)** Do not add oil with specifications other than those of the oil already in the engine.

**40)** Use a fluid of the same type as that already present in the reservoir for any topping up of the engine cooling system. The fluid cannot be mixed with other types of antifreeze fluids. In the event of topping up with an unsuitable product, under no circumstances start the engine and contact an Alfa Romeo Dealership.

**41)** Prevent brake fluid, which is highly corrosive, from coming into contact with painted parts. Should it happen, immediately wash with water.

**WARNING**

**130)** Never smoke while working in the engine compartment: gas and inflammable vapours may be present, with the risk of fire.

**131)** Be very careful when working in the engine compartment when the engine is hot: you may get burned. Do not get too close to the radiator cooling fan: the electric fan may start; danger of injury. Scarves, ties and other loose clothing might be pulled by moving parts.



**132)** If the engine oil is being topped up, wait for the engine to cool down before loosening the filler cap, particularly for vehicles with aluminium cap (where provided). **WARNING:** risk of burns!

**133)** The cooling system is pressurised. If necessary, only replace the plug with another original or the operation of the system may be adversely affected. Do not remove the reservoir plug when the engine is hot: you risk scalding yourself.

**134)** Do not travel with the windscreen washer fluid reservoir empty: the windscreen washer is essential for improving visibility. Repeated operation of the system without fluid could damage or cause rapid deterioration of some system components.

**135)** Some commercial additives for windscreen washer fluid are flammable. The engine compartment contains hot components which may start a fire.

**136)** Brake fluid is poisonous and highly corrosive. In the event of accidental contact, immediately wash the affected parts with water and mild soap. Then rinse thoroughly. Call a doctor immediately if swallowed.

**137)** The symbol , on the brake fluid container indicates if a brake fluid is synthetic or mineral-based. Use of mineral type fluids will damage the special rubber seals of the braking system beyond repair.



## IMPORTANT

**2)** Used engine oil and oil filters contain substances which are harmful to the environment. To change the oil and filters, we advise you to contact an Alfa Romeo Dealership.

**3)** Used transmission fluid contains substances that are harmful to the environment. You are advised to contact an Alfa Romeo Dealership for oil changes.

## BATTERY RECHARGING

**IMPORTANT** The battery recharging procedure is given as information only. To carry out this operation contact an Alfa Romeo Dealership.

**IMPORTANT** After turning the ignition key to STOP and having closed the driver's side door, wait at least one minute before disconnecting and then reconnecting the electrical supply to the battery.

Charging should be slow at a low ampere rating for approximately 24 hours. Charging for a longer time may damage the battery.

**IMPORTANT** The cables of the electrical system must be correctly reconnected to the battery, i.e. the positive cable (+) to the positive terminal and the negative cable (-) to the negative terminal. The battery terminals are marked with the positive (+) and negative (-) symbols, and are shown on the battery cover. The battery terminals must also be corrosion-free and firmly secured to the terminals. If a "quick-type" battery charger is used with the battery fitted on the vehicle, before connecting it disconnect both cables of the battery itself. Do not use a "quick-type" battery charger to provide the starting voltage. The cables of the electrical system must



ABC

be correctly reconnected to the battery, i.e. the positive cable (+) to the positive terminal and the negative cable (-) to the negative terminal. The battery terminals are marked with the positive (+) and negative (-) symbols, and are shown on the battery cover. The battery terminals must also be corrosion-free and firmly secured to the terminals.

### VERSIONS WITHOUT START&STOP SYSTEM

(where provided)

To recharge, proceed as follows:

- disconnect the terminal from the negative battery pole;
- connect the charger cables to the battery terminals, observing the polarity;
- turn on the charger;
- when it is recharged, turn the charger off before disconnecting it from the battery;
- reconnect the terminal to the negative battery pole.

### VERSIONS WITH START&STOP SYSTEM

To recharge, proceed as follows:

- disconnect the connector 1 fig. 124 (pressing the button 2) from the sensor 3 monitoring the battery conditions, on the negative pole (-) 4 of the battery;
- connect the positive cable (+) of the battery charger to the positive battery

pole (+) and the negative cable (-) of the charger to terminal 4 of the negative battery pole (-);

- turn on the battery charger. When it is recharged, turn the charger off before disconnecting it from the battery;
- after having disconnected the charging device, reconnect connector 1 to the sensor 3 of the battery.

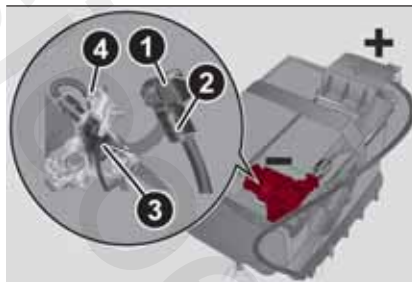

124

A0J0389C

## WINDSCREEN / REAR WINDOW WIPERS

### WIPER BLADES



### Raising the windscreen wiper blades

Proceed as follows:

- rotate the ignition key to MAR position and operate the steering wheel right lever to engage once the windscreen wiper blade. Turn the ignition key to the STOP position when the driver side wiper blade reaches the windscreen side pillar and lift the windscreen wiper to the rest position;
- bring the wiper blades back into contact with the windscreen before activating the windscreen wiper.

### Replacing the windscreen wiper blades

Proceed as follows:

- raise the wiper arm, press tab 1 fig. 125 of the attachment spring and remove the blade from the arm;
- fit the new blade by inserting the tab into the special slot in the arm. Make sure that it is properly locked into place.
- lower the wiper arm onto the windscreen.



125

A0J0054C

**IMPORTANT** Do not operate the windshield wiper with the blades lifted from the windshield.

### Replacing the rear window wiper blade

Proceed as follows:

- raise the cover 1 fig. 126, undo the nut 2 and remove the arm 3;
- correctly position the new arm, fully tighten the nut 2 then lower the cover 1.



126

A0J0057C

## NOZZLES

### Windscreen washer

The window washer nozzles are fixed fig. 127. If there is no jet of fluid, first check that there is some fluid in the reservoir (see paragraph "Checking fluid levels"). Then check that the nozzle holes are not clogged, if necessary use a needle.

**IMPORTANT** In versions with sun roof, make sure that the roof is closed before operating the windshield washer nozzles.

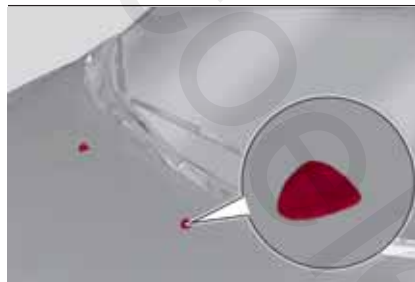

127

A0J0053C

### Rear window washer

The nozzle holder is on the rear window. The rear window washer jets are fixed.



128

A0J0055C



### WARNING

**138)** Driving with worn windscreen/rear window wiper blades is a serious hazard, because visibility is reduced in bad weather.



### IMPORTANT

**42)** Do not operate the windshield wiper with the blades lifted from the windshield.



ABC

## BATTERY

The battery 6 (see previous pages) does not require the electrolyte to be topped up with distilled water. A periodic check carried out at an Alfa Romeo Dealership is, however, necessary to check efficiency.

### INSPECTING THE CHARGE AND THE ELECTROLYTE LEVEL

 139) 140) 141) 142)

 43)

 4)

If necessary, replace the battery with another original battery with the same specifications. Follow the battery manufacturer's instructions for maintenance.

### USEFUL ADVICE FOR EXTENDING THE LIFE OF YOUR BATTERY

To avoid draining your battery and make it last longer, observe the following instructions:

- when you park the car, ensure that the doors, tailgate and bonnet are closed properly, to prevent any lights from remaining on inside the passenger's compartment;
- switch off all roof lights inside the car: the car is however equipped with a system which switches all internal lights off automatically;

do not keep accessories (e.g. radio, hazard warning lights, etc.) switched on for a long time when the engine is not running;

before performing any operation on the electrical system, disconnect the negative battery cable.

**IMPORTANT** If the charge level remains under 50% for a long time, the battery is damaged by sulphation, reducing its capacity and efficiency at start-up.

The battery will also be more at risk of freezing (this can happen as early as -10°C). Refer to the "Vehicle inactivity" paragraph in "Starting and driving" chapter if the vehicle is left parked for a long time.

If, after purchasing the car, you wish to install electrical accessories which require permanent electrical supply (e.g. alarm, etc.) or accessories which influence the electrical supply requirements, contact an Alfa Romeo Dealership, whose qualified staff will evaluate the overall electrical consumption.



### WARNING

**139)** Battery fluid is poisonous and corrosive. Avoid contact with the skin and eyes. Keep open flames away from the battery and do not use objects that might create sparks: risk of explosion and fire.

**140)** Using the battery with insufficient fluid irreparably damages the battery and may cause an explosion.

**141)** If the vehicle must remain unused for a long time at a very low temperature, remove the battery and take it to a warm place, to avoid freezing.

**142)** When performing any operation on the battery or near it, always protect your eyes with special goggles.



### IMPORTANT

**43)** Incorrect installation of electric and electronic devices may cause severe damage to your car. After purchasing your vehicle, if you wish to install any accessories (e.g. anti-theft, radio phone, etc.), go to an Alfa Romeo Dealership, which will suggest the most suitable devices and advise you whether a higher capacity battery needs to be installed.



## IMPORTANT

4) Batteries contain substances which are very dangerous for the environment. For battery replacement, contact an Alfa Romeo Dealership.

## LIFTING THE VEHICLE

If the car needs to be jacked up, go to an Alfa Romeo Dealership which is equipped with shop jacks and jack arms.

**IMPORTANT** Be careful when positioning the arm of the lift for versions with side skirts.

## BODYWORK

### PRESERVING THE BODYWORK

 44)

 5)

### Paint

Touch up abrasions and scratches immediately to prevent the formation of rust. Maintenance of paintwork consists of washing the car: the frequency depends on the conditions and environment where the car is used. For example, it is advisable to wash the vehicle more often in areas with high levels of atmospheric pollution or salted roads.

On some versions the car may be equipped, on request, with an exclusive opaque paint on the roof which, in order to be maintained intact, requires special care: see the instructions in the warning.

 45)

To correctly wash the vehicle, follow these instructions:

- if the vehicle is washed remove the aerial from the roof;
- if high pressure jets or cleaners are used to wash the car, keep a distance of at least 40 cm from the bodywork to avoid damage or alteration. Bear in mind that a build up of water could cause damage to the car in the long term;



ABC

- ❑ wash the bodywork using a low pressure jet of water;
- ❑ wipe a sponge with a slightly soapy solution over the bodywork, frequently rinsing the sponge;
- ❑ rinse well with water and dry with a jet of air or a chamois leather.

Dry the less visible parts (e.g. door frames, bonnet, headlight frames, etc.) with special care, as water may stagnate more easily in these areas. Do not wash the car after it has been left in the sun or with the bonnet hot: this may alter the shine of the paintwork.

Exterior plastic parts must be cleaned in the same way as the rest of the vehicle.

### IMPORTANT NOTES

Avoid parking under trees; the resin dropped by trees makes the paintwork go opaque and increases the possibility of corrosion.

Bird droppings must be washed off immediately and thoroughly as the acid they contain is particularly aggressive.

### Windows

Use specific detergents and clean cloths to prevent scratching or altering the transparency.

**IMPORTANT** Wipe the rear window inside gently with a cloth following the direction of the filaments to avoid damaging the heating device.

### Front headlights

Use a soft cloth soaked in water and detergent for washing cars.

**IMPORTANT** Never use aromatic substances (e.g. petrol) or ketones (e.g. acetone) for cleaning the plastic lenses of the headlights.

**IMPORTANT** When cleaning with a pressure washer, keep the water jet at least 20 cm away from the headlights.

### Engine compartment

At the end of every winter, wash the engine compartment thoroughly, taking care not to aim the jet of water directly at the electronic control units or at the windscreen wiper motors. Have this operation performed at a specialised workshop.

**IMPORTANT** The washing should take place with the engine cold and the ignition key in the STOP position. After the washing operation, make sure that the various protections (e.g. rubber caps and guards) have not been removed or damaged.



### IMPORTANT

**5)** Detergents pollute the environment. Only wash your vehicle in areas equipped to collect and treat wastewater from this type of activity.



### IMPORTANT

**44)** In order to preserve the aesthetic appearance of the paint abrasive products and/or polishes should not be used for cleaning the vehicle.

**45)** Avoid washing with rollers and/or brushes in washing stations. Wash the vehicle only by hand using neutral pH detergents; dry it with a wet chamois leather. Abrasive products and/or polishes should not be used for cleaning the car. Bird droppings must be washed off immediately and thoroughly as the acid they contain is particularly aggressive. Avoid (if at all possible) parking the vehicle under trees; remove vegetable resins immediately as, when dried, it may only be possible to remove them with abrasive products and/or polishes, which is highly inadvisable as they could alter the typical opaqueness of the paint. Do not use pure windscreen washer fluid for cleaning the front windscreen and rear window; dilute it min. 50% with water. Only use pure screen washer fluid when strictly necessary due to outside temperature conditions.

## INTERIOR

 143) 144) 145)

Periodically check the cleanliness of the interior, beneath the mats, which could cause oxidation of the sheet metal.

### SEATS AND FABRIC PARTS

Remove dust with a soft brush or a vacuum cleaner. It is advisable to use a moist brush on velvet upholstery. Rub the seats with a sponge moistened with a solution of water and neutral detergent.

### CLEANING ALCANTARA SEATS

Alcantara trim can be treated and cleaned easily in the same way as the other trims. The same indications given for cleaning fabrics are also therefore applicable for this trim.

### LEATHER SEATS

(where provided)

Remove the dry dirt with a chamois or slightly damp cloth, without exerting too much pressure. Remove any liquid or grease stains using an absorbent dry cloth, without rubbing. Then clean with a soft cloth or buckskin cloth dampened with water and mild soap. If the stain persists, use specific products and observe the instructions carefully.

**IMPORTANT** Never use alcohol. Make sure that the cleaning products used

contain no alcohol or alcohol derivatives, even in small quantities.

### PLASTIC AND COATED PARTS

 46)

Clean interior plastic parts with a damp cloth (if possible made from microfibre), and a solution of water and neutral, non-abrasive detergent. To clean oily or persistent stains, use specific products free from solvents and designed to maintain the original appearance and colour of the components.

Remove any dust using a microfibre cloth, if necessary moistened with water. The use of paper tissues is not recommended as these may leave residues.

### GENUINE LEATHER PARTS

(where provided)

Use only water and mild soap to clean these parts. Never use alcohol or alcohol-based products. Before using a specific product for cleaning interiors, make sure that it does not contain alcohol and/or alcohol based substances.



### WARNING

**143)** Never use flammable products, such as petrol ether or rectified petrol to clean the inside of the car. The electrostatic charges which are generated by rubbing during the cleaning operation may cause a fire.

**144)** Do not keep aerosol cans in the car: they might explode. Aerosol cans must not be exposed to a temperature exceeding 50°C. When the vehicle is exposed to sunlight, the internal temperature can greatly exceed this value.

**145)** There must be no obstacles on the floor underneath the pedals; make sure that mats are always flat and do not interfere with the pedals.



### IMPORTANT

**46)** Never use alcohol, petrols and derivatives to clean the dashboard and instrument panel lens.



ABC

musicteacher.ir

*This page is intentionally left blank*





## TECHNICAL SPECIFICATIONS

IDENTIFICATION DATA . . . . .	152
VEHICLE IDENTIFICATION NUMBER (VIN) PLATE . . . . .	152
CHASSIS NUMBER . . . . .	153
ENGINE MARKING . . . . .	153
ENGINE . . . . .	154
WHEELS . . . . .	159
DIMENSIONS . . . . .	165
WEIGHTS . . . . .	166
REFUELLING . . . . .	169
FLUIDS AND LUBRICANTS . . . . .	172
PERFORMANCE . . . . .	175
FUEL CONSUMPTION . . . . .	176
CO2 EMISSIONS . . . . .	178
PRESCRIPTIONS FOR HANDLING THE VEHICLE AT THE END OF ITS LIFE . . . . .	179

Everything you may find useful for understanding how your car is made and works is contained in this chapter and illustrated with data, tables and graphics. For the enthusiasts and the technician, but also just for those who want to know every detail of their car.

## IDENTIFICATION DATA

The identification data of the vehicle are:

- VIN plate;
- Chassis marking;
- Bodywork paint identification plate;
- Engine marking.

## VEHICLE IDENTIFICATION NUMBER (VIN) PLATE

This plate is fitted to the engine compartment front crossmember and contains the following identification data fig. 129:

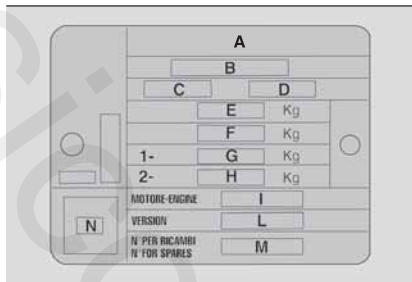

129

A0J0161C

TO: Name of Manufacturer

B: Type-approval number

C: Vehicle type identification code

D: Chassis number

E: Maximum permitted weight of vehicle fully laden

F: Maximum permitted weight of vehicle fully laden plus trailer

G: Maximum permitted weight on front axle

H: Maximum permitted weight on second (rear) axle

I: Engine type

L: Bodywork version code

M: Spares number

N: Smoke opacity index (for diesel engines)

## CHASSIS NUMBER

This is printed on the passenger compartment floor, next to the front right seat.

Slide flap 1 fig. 130 to access.

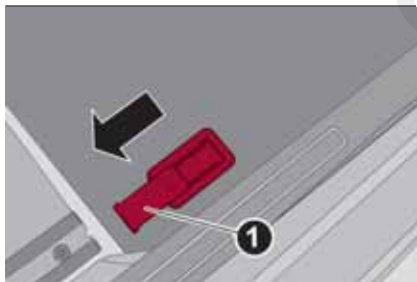

I30

A0J0140C

The marking includes:

- vehicle type (ZAR955000);
- chassis serial number.

## ENGINE MARKING

It is stamped on the cylinder block and includes the type and the engine serial number.



ABC

**ENGINE**

GENERAL INFORMATION	Turbo TwinAir 105 HP		Turbo TwinAir 100 HP (*)
Engine code	199B6000		199B7000
Cycle	Otto		Otto
Number and position of cylinders	4 in line		4 in line
Piston bore and stroke (mm)	80.5 × 86		72.0 × 84.0
Total displacement (cm <sup>3</sup> )	875		875
Compression ratio	10		10
	NATURAL	DYNAMIC	
Maximum power (EC) (kW)	72	77	73.5
Maximum power (EEC) (HP)	98	105	100
corresponding engine speed (rpm)	5750	5500	5500
Maximum torque (EC) (Nm)	120	145	145
Maximum torque (EC) (kgm)	12.2	14.8	14.8
corresponding engine speed (rpm)	1750	2000	2100
Spark plugs	NGK ILKR9G8		NGK ILKR9G8
Fuel	Unleaded petrol 95 R.O.N. (EN 228 specifications)		Unleaded petrol 95 R.O.N. (EN 228 specifications)

(\*) Version for specific markets

GENERAL INFORMATION	1.4 Petrol 8V 78 HP	1.4 Turbo Petrol/LPG 120 HP	
Engine code	350A1000	198A4000	
Cycle	Otto	Otto	
Number and position of cylinders	4 in line	4 in line	
Piston bore and stroke (mm)	72.0 × 84.0	72.0 × 84.0	
Total displacement (cm <sup>3</sup> )	1368	1368	
Compression ratio	11.1	9.8	
		LPG	PETROL
Maximum power (EC) (kW)	57	88	88
Maximum power (EEC) (HP)	78	120	120
corresponding engine speed (rpm)	6000	5000	5000
Maximum torque (EC) (Nm)	115	206	206
Maximum torque (EC) (kgm)	11.7	21	21
corresponding engine speed (rpm)	3000	1750	2000
Spark plugs	NGK ZKR7AI-8	NGK IKR9J8	
Fuel	Unleaded petrol 95 R.O.N. (EN 228 specifications)	LPG (EN589 specification)	Unleaded petrol 95 R.O.N. (EN 228 specifications)



ABC

GENERAL INFORMATION	1.4 Turbo MultiAir 135 HP		1.4 Turbo Multi Air 135/140 HP TCT	
Engine code	955A2000		955A7000 (*)	
			955B1000 (**)	
Cycle	Otto		Otto	
Number and position of cylinders	4 in line		4 in line	
Piston bore and stroke (mm)	72.0 × 84.0		72.0 × 84.0	
Total displacement (cm <sup>3</sup> )	1368		1368	
Compression ratio	9.8		9.8	
Maximum power (EC) (kW)	99		99 (*) / 103 (**)	
Maximum power (EEC) (HP)	135		135 (*) / 140 (**)	
corresponding engine speed (rpm)	5000		5000	
	NATURAL	DYNAMIC	NATURAL	DYNAMIC
Maximum torque (EC) (Nm)	190	206	230	250
Maximum torque (EC) (kgm)	19.3	21	23.4	25.5
corresponding engine speed (rpm)	4250	1750	2250	2500
Spark plugs	NGK IKR9F8		NGK IKR9J8	
Fuel	Unleaded petrol 95 R.O.N. (EN 228 specifications)		Unleaded petrol 95 R.O.N. (EN 228 specifications)	

(\*) 1.4 Turbo Multi Air 135 HP TCT version (where provided)

(\*\*) 1.4 Turbo Multi Air 140 HP TCT version

GENERAL INFORMATION	1.4 Turbo MultiAir 170 HP		1.4 Turbo MultiAir 170 HP TCT	
Engine code	940A2000		940A2000	
Cycle	Otto		Otto	
Number and position of cylinders	4 in line		4 in line	
Piston bore and stroke (mm)	72.0 × 84.0		72.0 × 84.0	
Total displacement (cm <sup>3</sup> )	1368		1368	
Compression ratio	9.8		9.8	
Maximum power (EC) (kW)	125		125	
Maximum power (EEC) (HP)	170		170	
corresponding engine speed (rpm)	5000		5000	
	NATURAL	DYNAMIC	NATURAL	DYNAMIC
Maximum torque (EC) (Nm)	230	250	230	250
Maximum torque (EC) (kgm)	23.4	25.5	23.4	25.5
corresponding engine speed (rpm)	2250	2500	2250	2500
Spark plugs	NGK IKR9J8		NGK IKR9J8	
Fuel	Unleaded petrol 95 R.O.N. (EN 228 specifications)		Unleaded petrol 95 R.O.N. (EN 228 specifications)	



ABC

GENERAL INFORMATION	1.3 JTD M-2 90 HP (*)	1.3 JTD M-2 95 HP
Engine code	955B2000	330A1000
Cycle	Diesel	Diesel
Number and position of cylinders	4 in line	4 in line
Piston bore and stroke (mm)	69.6 × 82	69.6 × 82
Total displacement (cm <sup>3</sup> )	1248	1248
Compression ratio	16.8	16.8
Maximum power (EC) (kW)	66	70
Maximum power (EEC) (HP)	90	95
corresponding engine speed (rpm)	3750	3750
Maximum torque (EC) (Nm)	200	200
Maximum torque (EC) (kgm)	20.4	20.4
corresponding engine speed (rpm)	1500	1500
Fuel	Diesel for motor vehicles (EN590 Specification)	Diesel for motor vehicles (EN590 Specification)

(\*) Version for specific markets



## WHEELS

### RIMS AND TYRES PROVIDED



146) 147)

Versions	Wheels	Tyres provided	Snow tyres	Space saver spare wheel	
				Rim	Tyre
<b>Turbo TwinAir</b>	6Jx15 ET 40	185/65 R15 88H	185/65 R15 88H (M+S)	135/70 R16	4Bx 16 ET 15
	7Jx16 ET 39	195/55 R16 87H	195/55 R16 87H (M+S)		
	7Jx17 ET 39	215/45 R17 87V (*)	215/45 R17 87H (M+S)		
	7Jx17 ET 39	215/45 R17 87W (*)	215/45 R17 87H (M+S)		
	7 1/2 Jx18 ET 42	215/40 R18 89WXL (*)	215/40 R18 89H (M+S)		
<b>1.4-litre Petrol</b>	6Jx15 ET 40	185/65 R15 88T	185/65 R15 88T (M+S)	135/70 R16	4Bx 16 ET 15
	6Jx15 ET 40 (**)	185/65 R15 88V (**)	185/65 R15 88Q (M+S)		
	7Jx16 ET 39	195/55 R16 87H	195/55 R16 87H (M+S)		
	7Jx17 ET 39	215/45 R17 87V (*)	215/45 R17 87H (M+S)		
	7 1/2 Jx18 ET 42	215/40 R18 89WXL (*)	215/40 R18 89H (M+S)		

(\*) Tyres which cannot be fitted with chains

(\*\*) Where fitted



ABC

Versions	Wheels	Tyres provided	Snow tyres	Space saver spare wheel	
				Rim	Tyre
<b>1.4 Turbo Petrol/LPG 120 HP</b>	7Jx16 ET 39	195/55 R16 87H	195/55 R16 87H (M+S)	135/70 R16	4B x 16 ET 15
	7Jx17 ET 39	215/45 R17 87V (*)	215/45 R17 87H (M+S)		
	7 1/2 Jx18 ET 42	215/40 R18 89W XL (*)	215/40 R18 89H (M+S)		
<b>1.4 Turbo Multi Air / 1.4 Turbo Multi Air Veloce</b>	6Jx15 ET 40 (**)	185/65 R15 88V (**)	185/65 R15 88Q (M+S)	135/70 R16	4B x 16 ET 15
	7Jx16 ET 39	195/55 R16 87V	195/55 R16 87H (M+S)		
	7Jx17 ET 39 (**)	205/45 R17 88W XL (**)	205/45 R17 88H (M+S)		
	7Jx17 ET 39 (**)	215/45 R17 87V (**)	215/45 R17 87H (M+S)		
	7Jx17 ET 39	215/45 R17 87W (*)	215/45 R17 87H (M+S)		
	7 1/2 Jx18 ET 42	215/40 R18 89W XL (*)	215/40 R18 89H (M+S)		
	7Jx16 ET 39	195/55 R16 87V	195/55 R16 87H (M+S)		
	7Jx17 ET 39	215/45 R17 87V	215/45 R17 87H (M+S)		
<b>1.4 Turbo MultiAir TCT</b>	7 1/2 Jx18 ET 42	215/40 R18 89W XL	215/40 R18 89H (M+S)	135/70 R16	4B x 16 ET 15

(\*) Tyres which cannot be fitted with chains

(\*\*) Where fitted

Versions	Wheels	Tyres provided	Snow tyres	Space saver spare wheel	
				Rim	Tyre
<b>1.3 JTD M-2</b>	7Jx16 ET 39	195/55 R16 87H	195/55 R16 87H (M+S)	135/70 R16	4Bx16 ET 15
	7Jx17 ET 39	215/45 R17 87V	215/45 R17 87H (M+S)		
	7 1/2 Jx18 ET 42	215/40 R18 89WXL	215/40 R18 89H (M+S)		
<b>Turbo TwinAir 100 HP / 1.3 JTD M-2 90 HP (***)</b>	7Jx16 ET 39	195/55 R16 87H Continental Premium Contact 2	195/55 R16 87Q (M+S)	135/70 R16	4Bx16 ET 15

(\*\*\*) For specific markets. Otherwise use tyres offering equivalent performance.

**IMPORTANT** If there are any discrepancies between the Owner Handbook and the registration document, take the information from the latter. For safe driving, the car must be fitted with tyres of the same make and type on all wheels.



ABC

**COLD TYRE INFLATION PRESSURE (bar)**

VERSIONS	MEASUREMENT	TYRES PROVIDED			
		MEDIUM LOAD		FULL LOAD	
		Front	Rear	Front	Rear
<b>Turbo TwinAir</b>	185/65 R15 88H	2.3	2.1	2.3	2.3
	195/55 R16 87H	2.3	2.1	2.3	2.3
	215/45 R17 87V	2.2	2.1	2.3	2.3
	215/45 R17 87W	2.2	2.1	2.3	2.3
	215/40 R18 89WXL	2.3	2.1	2.3	2.3
<b>1.4-litre Petrol</b>	185/65 R15 88T	2.3	2.1	2.3	2.3
	195/55 R16 87H	2.3	2.1	2.3	2.3
	215/45 R17 87V	2.2	2.1	2.3	2.3
	215/45 R17 87W	2.2	2.1	2.3	2.3
	215/40 R18 89WXL	2.3	2.1	2.3	2.3
<b>1.4 Turbo Petrol/LPG 120 HP</b>	195/55 R16 87H	2.3	2.1	2.5	2.3
	215/45 R17 87V	2.3	2.1	2.6	2.3
	215/40 R18 89WXL	2.4	2.2	2.7	2.4
<b>1.4 Turbo Multi Air / 1.4 Turbo Multi Air Veloce</b>	185/65 R15 88V	2.3	2.1	2.5	2.3
	195/55 R16 87V	2.3	2.1	2.5	2.3
	205/45 R17 88WXL	2.4	2.2	2.8	2.5
	215/45 R17 87V	2.3	2.1	2.6	2.3
	215/45 R17 87W	2.3	2.1	2.6	2.3
	215/40 R18 89WXL	2.4	2.2	2.7	2.4
<b>1.4 Turbo MultiAir TCT</b>	195/55 R16 87V	2.3	2.1	2.5	2.3
	215/45 R17 87V	2.3	2.1	2.6	2.3
	215/40 R18 89WXL	2.4	2.2	2.7	2.4
<b>1.3 JTD<sub>M-2</sub></b>	195/55 R16 87H	2.3	2.1	2.6	2.3
	215/45 R17 87V	2.3	2.1	2.5	2.3
	215/40 R18 89WXL	2.6	2.4	2.6	2.4
<b>Space saver spare wheel</b>	135/70 R16			4.2	

When the tires are warm, the inflation pressure should be + 0.3 bar in relation to the recommended figure. Check correct pressure when the tyres are cold.

With snow tyres, add +0.2 bar to the prescribed pressure for standard tyres.

When travelling at speeds over 160 km/h, inflate the tyres to the values specified for fully laden conditions.



ABC

**SNOW CHAINS**

47)

The use of snow chains should be in compliance with local regulations. The snow chains may be applied only onto the front wheel (drive wheels).

Check the tension of the snow chains after the first few metres have been driven.

Use low-clearance snow chains: for tyres 185/65 R15 88H (where provided), 195/55 R16 and 205/55 R16, use low-clearance snow chains with a maximum projection beyond the tyre profile of 9 mm.

**IMPORTANT** The space-saver wheel cannot be fitted with snow chains. If a front (drive) wheel is punctured and snow chains must be used, you must remove a normal wheel from the rear axle and replace it with the space-saver wheel. In this way, with two normal drive wheels, it is possible to use snow chains.

**WARNING**

**146)** *The maximum speed for snow tyres marked "Q" is 160 km/h, while it is 190 km/h for "T" tyres and 210 km/h for "H" tyres. The highway code speed limits must however always be complied with.*

**147)** *DO NOT fit wheel hub caps when using integral hub caps fixed (with springs) to the steel rim and after sale tyres provided with Rim Protector. Use of unsuitable tyres and wheel caps may cause sudden decrease of tyre pressure.*

**IMPORTANT**

**47)** *Keep the vehicle's speed down when snow chains are fitted; never exceed 50 km/h. Avoid potholes, steps and pavements and avoid driving long distances on roads not covered with snow to avoid damaging the car and the roadbed.*

## DIMENSIONS

Dimensions are expressed in mm and refer to the vehicle equipped with its standard-supplied tyres. Height is measured with vehicle unladen.

**LUGGAGE COMPARTMENT VOLUME** Unladen capacity (V.D.A. standards) = 270 dm<sup>3</sup>. **Versions with LPG system** = 247 dm<sup>3</sup>



131

A010202C

A	B	C	D	E	F (*)	G	H (*)
4063	904	2511	648	1446	1475	1720	1469

(\*) Small variations in size are possible, depending on the dimensions of the rims and tyres.



ABC

**WEIGHTS**

Weights (kg)	Turbo TwinAir	1.4-litre Petrol
Unladen weight (with all fluids, fuel tank filled to 90% and without optional equipment)	1130	1080
Payload including the driver (*)	480 (**)/560 (***)	480 (**)/560 (***)
Maximum permitted loads (****)		
- front axle	950	850
- rear axle	850	850
- total	1610 (**)/1690 (***)	1560 (**)/1640 (***)
Towable loads		
- braked trailer	500	500
- trailer without brakes	400	400
Maximum load on roof	40	40
Maximum load on tow hitch (trailer with brakes)	60	60

(\*) If special equipment is fitted (sunroof, tow hitch, etc.) the unladen car weight increases, thus reducing the specified payload in relation to the maximum permissible loads.

(\*\*) 4-seater versions

(\*\*\*) 5-seater versions

(\*\*\*\*) Loads not to be exceeded. The user is responsible for arranging goods in the luggage compartment and/or load platform within the maximum permitted loads.



Weights (kg)	1.4 Turbo Petrol/LPG 120 HP	1.4 Turbo MultiAir
Unladen weight (with all fluids, fuel tank filled to 90% and without optional equipment)	1145	1135/1145 (*)
Payload including the driver (**)	480 (***)/560 (****)	480 (***)/560 (****)
Maximum permitted loads (*****)		
- front axle	950	950
- rear axle	850	850
- total	1625 (***)/1705 (****)	1625 (***)/1705 (****)
Towable loads		
- braked trailer	500	500
- trailer without brakes	400	400
Maximum load on roof	40	40
Maximum load on tow hitch (trailer with brakes)	60	60

(\*) 1.4 Turbo MultiAir 170 HP version

(\*\*) If special equipment is fitted (sunroof, tow hitch, etc.) the unladen car weight increases, thus reducing the specified payload in relation to the maximum permissible loads.

(\*\*\*) 4-seater versions

(\*\*\*\*) 5-seater versions

(\*\*\*\*\*) Loads not to be exceeded. The user is responsible for arranging goods in the luggage compartment and/or load platform within the maximum permitted loads.

**IMPORTANT** On versions 1.4 Turbo Multi Air 135 HP and 1.4 Turbo Multi Air Veloce towing trailers is prohibited.



ABC

Weights (kg)	1.4 Turbo MultiAir TCT	1.3 JTD <sub>M-2</sub>
Unladen weight (with all fluids, fuel tank filled to 90% and without optional equipment)	1170	1150
Payload including the driver (*)	480 (**)/560 (***)	480 (**)/560 (***)
Maximum permitted loads (****)		
- front axle	950	950
- rear axle	850	850
- total	1650 (**)/1730 (***)	1630 (**)/1710 (***)
Towable loads		
- braked trailer	500	1000
- trailer without brakes	400	400
Maximum load on roof	40	40
Maximum load on tow hitch (trailer with brakes)	60	60

(\*) If special equipment is fitted (sunroof, tow hitch, etc.) the unladen car weight increases, thus reducing the specified payload in relation to the maximum permissible loads.

(\*\*) 4-seater versions

(\*\*\*) 5-seater versions

(\*\*\*\*) Loads not to be exceeded. The user is responsible for arranging goods in the luggage compartment and/or load platform within the maximum permitted loads.

IMPORTANT On versions 1.4 Turbo Multi Air TCT 135 HP towing trailers is prohibited.

## REFUELLING

	Turbo TwinAir		1.4-litre Petrol		Prescribed fuels and original lubricants
	litres	kg	litres	kg	
Fuel tank	45	-	45	-	Unleaded petrol not less than 95 RON (EN 228 specification)
including a reserve of	5-7	-	5-7	-	
Engine cooling system (with climate control)	5.4	5.3	5.2	4.6	Mixture of distilled water and PARAFLU fluid <sup>UP</sup> 50% (*)
Engine sump	2.8	2.5	2.7	2.3	SELENIA DIGITEK P.E. (Turbo TwinAir versions) SELENIA StAR P.E. (1.4 Petrol versions)
Engine sump and filter	3.3	2.8	2.9	2.5	
Gearbox casing/differential	1.65	1.5	1.6	1.4	TUTELA TRANSMISSION GEARFORCE
Hydraulic brake circuit with ABS (Anti-lock braking system)	0.53	0.5	0.53	0.5	TUTELA TOP 4/S
Windscreen/rear window/headlight washer fluid reservoir (**)	2.2 (4.5)	1.9 (4.0)	2.8 (4.6)	2.5 (4.1)	Mixture of water and TUTELA PROFESSIONAL SC 35

(\*) When the vehicle is used in particularly harsh weather conditions, we recommend using a 60-40 mixture of PARAFLU<sup>UP</sup> and demineralised water.

(\*\*) Values in brackets refer to versions with headlight washer



ABC

	1.4 Turbo Petrol/LPG 120 HP		1.4 Turbo MultiAir		Prescribed fuels and original lubricants
	litres	kg	litres	kg	
Fuel tank	45	-	45	-	Unleaded petrol not less than 95 RON (EN228 specification)/LPG (1.4 Turbo Petrol/LPG 120 HP versions)
LPG tank (1.4 Turbo Petrol/LPG 120 HP versions) (*)	39	-	-	-	Unleaded petrol not less than 95 RON (EN228 specification) (1.4 Turbo MultiAir versions)
including a reserve of	5-7	-	5-7	-	
Engine cooling system (with climate control)	6.3	5.0	6.0	5.3	Mixture of distilled water and PARAFLU fluid <sup>UP</sup> 50% (**)
Engine sump	2.75	2.4	3.1	2.6	SELENIA MULTIPOWER GAS 5W-40 (1.4 Turbo Petrol/LPG 120 HP versions)
Engine sump and filter	3.3	2.9	3.5	3.0	SELENIA DIGITEK P.E. (1.4 Turbo MultiAir versions)
Gearbox casing/differential	2.0	1.7	2.0	1.7	TUTELA TRANSMISSION GEARFORCE
Hydraulic brake circuit with ABS (Anti-lock braking system)	0.53	0.5	0.53	0.5	TUTELA TOP 4/S
Windscreen/rear window/headlight washer fluid reservoir (***)	2.2 (4.5)	1.9 (4.0)	2.2 (4.5)	1.9 (4.0)	Mixture of water and TUTELA PROFESSIONAL SC 35

(\*) Maximum refuelling capacity including reserve

(\*\*) When the vehicle is used in particularly harsh weather conditions, we recommend using a 60-40 mixture of PARAFLU<sup>UP</sup> and demineralised water.

(\*\*\*) Values in brackets refer to versions with headlight washer

	1.3 JTD <sub>M-2</sub>		Prescribed fuels and original lubricants
	litres	kg	
Fuel tank	45	-	Diesel for motor vehicles (EN590 Specification)
including a reserve of	5-7	-	
Engine cooling system (with climate control)	7.2	6.4	Mixture of distilled water and PARAFLU fluid <sup>UP</sup> 50% (*)
Engine sump	3.7	3.0	SELENIA WR FORWARD
Engine sump and filter	3.9	3.25	
Gearbox casing/differential	1.8	1.5	TUTELA TRANSMISSION GEARFORCE
Hydraulic brake circuit with ABS (Anti-lock braking system)	0.53	0.5	TUTELA TOP 4/S
Windscreen/rear window/headlight washer fluid reservoir (**)	3.0 (6.0)	2.8 (5.6)	Mixture of water and TUTELA PROFESSIONAL SC 35

(\*) When the vehicle is used in particularly harsh weather conditions, we recommend using a 60-40 mixture of PARAFLU<sup>UP</sup> and demineralised water.

(\*\*) Values in brackets refer to versions with headlight washer



ABC

## FLUIDS AND LUBRICANTS

Your vehicle is equipped with an engine oil that has been thoroughly developed and tested in order to meet the requirements of the Scheduled Servicing Plan. Constant use of the prescribed lubricants guarantees the fuel consumption and emission specifications. Lubricant quality is crucial for engine operation and duration.

### PRODUCT SPECIFICATIONS



48)

Use	Features	Specification	Original fluids and lubricants	Replacement interval
Lubricant for petrol engines (Turbo TwinAir 105 HP/ 1.4 Turbo Multi Air versions)	SAE 0W-30 ACEA C2/ API SN	9.55535-GS1 or MS.90048	<b>SELENIA DIGITEK P.E.</b> Contractual Technical Reference No. F020.B12	According to Scheduled Servicing Plan
Lubricant for petrol engines (1.4 Petrol versions)	SAE 5W40 ACEA C3/ API SN	9.55535-S2	<b>SELENIA STAR P.E.</b> Contractual Technical Reference No. F603.D08	According to Scheduled Servicing Plan
Lubricant for petrol/LPG engines (1.4 Turbo Petrol/LPG 120 HP versions)	SAE 5W-40 ACEA C3/ API SN	9.55535-T2.	<b>SELENIA MULTIPOWER GAS 5W-40</b> Contractual Technical Reference No. F922.E09	According to Scheduled Servicing Plan
Lubricant for diesel engines	SAE 0W-30 ACEA C2/ API SN	9.55535-DS1 or MS.90047	<b>SELENIA WR FORWARD</b> Contractual Technical Reference No. F842.F13	According to Scheduled Servicing Plan

If lubricants conforming to the required specification are not available, products that meet the indicated specifications can be used to top up; in this case optimal performance of the engine is not guaranteed.

Use	Features	Specification	Original fluids and lubricants	Applications
Lubricants and greases for drive transmission	SAE 75W grade synthetic lubricant.	9.55550-MZ6 or MS.90030-M1	<b>TUTELA TRANSMISSION GEARFORCE</b> Contractual Technical Reference No. F002.F10	Mechanical differentials and gearboxes
	Molybdenum disulphide grease, for use at high temperatures. N.L.G.I. consistency 1-2	FIAT 9.55580 – GRASS II	<b>TUTELA ALL STAR</b> Contractual Technical Reference No. F702.G07	Wheel side constant velocity joints
	Grease for constant velocity joints with low friction coefficient. N.L.G.I. consistency 0-1	FIAT 9.55580 – GRASS II	<b>TUTELA STAR 700</b> Contractual Technical Reference No. F701.C07	Differential side constant velocity joints
Lubricant for electro-hydraulic actuator (versions with Alfa TCT)	Fully synthetic oil with dedicated additive	9.55550-SA1 or MS.90030-H1	<b>TUTELA CS SPEED</b> Contractual Technical Reference No. F005.F98	Lubricant for electro-hydraulic actuator
Brake fluid	Synthetic fluid for brake and clutch systems. Exceeds specifications FMVSS no. 116 DOT 4, ISO 4925 SAE J1704.	9.55597 or MS.90039	<b>TUTELA TOP 4/S</b> Contractual Technical Reference No. F001.A93	Hydraulic brakes and hydraulic clutch controls
Protective agent for radiators	Red protective with antifreeze action, based on inhibited monoethyl glycol with organic formula. Exceeds CUNA NC 956-16, ASTM D 3306 specifications.	9.55523 or MS.90032	<b>PARAFLU<sup>UP</sup>(*)</b> Contractual Technical Reference No. F101.M01	Percentage of use: 50% distilled water 50% <b>PARAFLU<sup>UP</sup>(**)</b>

(\*)IMPORTANT Do not top up or mix with other fluids which have different specifications from those described.

(\*\*)When the vehicle is used in particularly harsh weather conditions, we recommend using a mixture of 60% **PARAFLU<sup>UP</sup>** and 40% demineralised water.



ABC

Use	Features	Specification	Original fluids and lubricants	Applications
Diesel fuel additive	Antifreeze additive for diesel, with protective action for diesel engines.		<b>TUTELA DIESEL ART</b> Contractual Technical Reference No. F601.L06	To be mixed with diesel (25 cc per 10 litres)
Washer fluid for windscreen/rear window/headlamps	Mixture of alcohol, water and surfactants CUNA NC 956-11	9.55522 or MS.90043	<b>TUTELA PROFESSIONAL SC 35</b> Contractual Technical Reference No. F201.D02	To be used diluted or undiluted in screen washer/wiper systems



**IMPORTANT**

**48)** *The use of products with different specifications than those indicated above could cause damage to the engine that is not covered by the warranty.*



## PERFORMANCE

Versions	Maximum speed (km/h)	Acceleration from 0-100 km/h (sec)
<b>Turbo TwinAir 105 HP</b>	184	11.4
<b>1.4 Petrol 8V 78 HP</b>	165	13.0
<b>1.4 Turbo Petrol/LPG 120 HP</b>	198	8.8
<b>1.4 Turbo MultiAir 135 HP</b>	207	8.4
<b>1.4 Turbo MultiAir 135 HP TCT (*)</b>	207	8.2
<b>1.4 Turbo MultiAir 140 HP TCT (*)</b>	209	8.1
<b>1.4 Turbo MultiAir 170 HP TCT</b>	219	-
<b>1.4 Turbo Multi Air 170 HP Veloce</b>	219	7.5
<b>1.3 JTD M-2 90 HP (*)</b>	178	-
<b>1.3 JTD M-2 95 HP</b>	180	-

(\*) Where fitted



ABC

## FUEL CONSUMPTION

The fuel consumption figures given in the tables below are determined on the basis of the type-approval tests laid down by specific European Directives.

The following procedures are used to measure the fuel consumption:

- *urban cycle*: cold starting followed by driving that simulates urban use of the vehicle;
- *extra-urban cycle*: frequent accelerating in all gears, simulating extra-urban use of the car: speed varies between 0 and 120 km/h;
- *combined fuel consumption*: calculated with a weighting of approximately 37% of the urban cycle and 63% of the extra-urban cycle.

**IMPORTANT** The type of route, traffic conditions, weather conditions, driving style, general condition of the car, trim level/equipment/accessories, use of the climate control system, car load, presence of roof racks and other situations that adversely affect the aerodynamics or wind resistance lead to different fuel consumption values than those measured. The fuel consumption will get more regular only after having driven the first 3000 km.

### FUEL CONSUMPTION ACCORDING TO THE CURRENT EUROPEAN DIRECTIVE (litres/100 km)

Versions	Urban	Extra-urban	Combined
<b>Turbo TwinAir 100 HP</b> <sup>(*)</sup> <sup>(****)</sup>	4.5	3.4	3.8
<b>Turbo TwinAir 105 HP</b> <sup>(*)</sup>	5.0	3.8	4.2
<b>1.4 Petrol 8V 78 HP</b>	7.3	4.6	5.6
<b>1.4 Turbo Petrol/LPG 120 HP</b>	8.2 <sup>(**)</sup> /10.6 <sup>(****)</sup>	5.1 <sup>(**)</sup> /6.6 <sup>(****)</sup>	6.2 <sup>(**)</sup> /8.1 <sup>(****)</sup>
<b>1.4 Turbo Petrol/LPG 120 HP</b> <sup>(****)</sup>	8.1 <sup>(**)</sup> /10.4 <sup>(****)</sup>	5.0 <sup>(**)</sup> /6.5 <sup>(****)</sup>	6.1 <sup>(**)</sup> /7.9 <sup>(****)</sup>
<b>1.4 Turbo MultiAir 135 HP</b>	7.4	4.5	5.6
<b>1.4 Turbo MultiAir 135 HP TCT</b> <sup>(****)</sup>	7.1	4.5	5.5
<b>1.4 Turbo MultiAir 140/170 HP TCT</b>	7.0	4.4	5.4

<sup>(\*)</sup> Type-approval test starting in 2<sup>nd</sup> gear.

<sup>(\*\*\*\*)</sup> Version for specific markets

<sup>(\*\*)</sup> Running on petrol

<sup>(\*\*\*\*)</sup> Running on LPG

Versions	Urban	Extra-urban	Combined
<b>1.4 Turbo Multi Air 170 HP Veloce</b>	8.1	4.8	6.0
<b>1.3 JTD M-2 90 HP (****)</b>	4.1	2.6	3.2
<b>1.3 JTD M-2 95 HP</b>	4.3/4.2 (****)	2.9/2.7 (****)	3.4/3.3 (****)

(\*\*\*\*) Version for specific markets



ABC

## CO<sub>2</sub> EMISSIONS

The CO<sub>2</sub> emission levels given in the following tables refer to combined consumption.

Versions	CO emissions <sub>2</sub> according to the European Directive in force (g/km)
<b>Turbo TwinAir 100 HP (*)</b>	88
<b>Turbo TwinAir 105 HP</b>	99
<b>1.4 Petrol 8V 78 HP</b>	130
<b>1.4 Turbo Petrol/LPG 120 HP</b>	131 (**)/145 (***)
<b>1.4 Turbo Petrol/LPG 120 HP (*)</b>	129 (**)/143 (***)
<b>1.4 Turbo MultiAir 135 HP (*)</b>	128
<b>1.4 Turbo MultiAir 135 HP TCT (*)</b>	126
<b>1.4 Turbo Multi Air 170 HP Veloce</b>	139
<b>1.4 Turbo MultiAir 170 HP TCT</b>	124
<b>1.3 JTD M-290 HP (*)</b>	83
<b>1.3 JTD M-295 HP</b>	89 / 86 (*)

(\*) Version for specific markets

(\*\*) Running on LPG

(\*\*\*) Running on petrol

## **PRESCRIPTIONS FOR HANDLING THE VEHICLE AT THE END OF ITS LIFE**

(where provided)

FCA has been committed for many years to safeguarding the environment through the constant improvement of its production processes and manufacturing products that are increasingly "eco-compatible". To grant customers the best possible service in terms of respecting environmental laws and in response to European Directive 2000/53/EC governing vehicles at the end of their life, FCA is offering its customers the chance to hand over their vehicle at the end of its life without incurring any additional costs. The European Directive sets out that when the vehicle is handed over, the last keeper or owner should not incur any expenses as a result of it having a zero or negative market value.

To hand your vehicle over at the end of its life without extra cost, contact one of our dealerships if you are purchasing another vehicle or an FCA-authorized collection and scrapping centre. These centres have been carefully chosen to offer high quality service for the collection, treatment and recycling of vehicles at their end of life, respecting the surrounding environment.

You can find further information on these collection and scrapping centres either from an FCA dealership or by calling the number in the Warranty Booklet or by consulting the websites of the various FCA brands.



ABC

basic4elearning

*This page is intentionally left blank*



## MULTIMEDIA

TIPS, CONTROLS AND GENERAL INFORMATION . . . . .	182
Uconnect™ 5" Radio LIVE - Uconnect™ 5" Radio Nav LIVE . . . . .	183
IMPORTANT INFORMATION AND RECOMMENDATIONS . . . . .	195



This chapter describes the main functions of the infotainment systems for the Uconnect™ 5" Radio LIVE, or Uconnect™ 5" Radio Nav LIVE that can be fitted on the vehicle.

## TIPS, CONTROLS AND GENERAL INFORMATION

### TIPS

 148) 149)

 49) 50)

### Road safety

Learn how to use the various system functions before setting off.

Read the instructions for the system carefully before setting off.

### Reception conditions

Reception conditions change constantly while driving. Reception may be interfered with by the presence of mountains, buildings or bridges, especially when you are far away from the broadcaster.

**IMPORTANT** The volume may be increased when receiving traffic information and news

### Care and maintenance

Observe the following precautions to ensure the system is fully operational:

- never use alcohol, petrol or petroleum-based solvents to clean the display screen;
- the display is sensitive to scratching, liquids and detergents. The display should not come into contact with pointed or rigid objects which could

damage its surface. Do not press on the display when cleaning it;

- prevent any liquid from entering the system: this could damage it beyond repair.

### SAFETY SETTINGS

Look at the screen only and when it is necessary and safe. If you need to look at the screen for a long time, pull over to a safe place so as not to be distracted while driving.

Immediately stop using the system in the event of a fault. Otherwise the system might be damaged. Contact an Alfa Romeo Dealership as soon as possible to have the system repaired.



### WARNING

**148)** Follow the safety rules here below: otherwise serious injuries may occur to the occupants or the system may be damaged.

**149)** If the volume is too loud this can be dangerous. Adjust the volume so that you can still hear background noises (e.g. horns, ambulances, police vehicles, etc.).



### IMPORTANT

**49)** Only clean the front panel and the display lens with a soft, clean, dry, anti-static cloth. Cleaning and polishing products may damage the surface. Never use alcohol, petrols and derivatives.

**50)** Do not use the display as a base for supports with suction pads or adhesives for external navigators or smartphones or similar devices



## Uconnect™ 5" Radio LIVE - Uconnect™ 5" Radio Nav LIVE

### CONTROLS ON FRONT PANEL







132

A0J0394C



ABC

## FRONT PANEL CONTROL SUMMARY TABLE

Button	Functions	Mode
1 - 	Power on/off	Short button press
	Volume adjustment	Left/right rotation of knob
2 - 	Volume activation/deactivation (Mute/Pause)	Short button press
3 - 	CD ejection	Short button press
4	CD housing	-
5 - 	Display on/off	Short button press
6 - 	Exit the selection/return to previous screen	Short button press
7 - <b>BROWSE ENTER</b>	Scrolling the list or tuning to a radio station	Left/right rotation of knob
	Confirmation of the option displayed	Short button press
8 - <b>APPS</b>	Access to additional functions: Display of time, Trip Computer, Compass, External temperature, Settings, <b>Uconnect™</b> LIVE services (where provided)	Short button press
9 - <b>PHONE</b>	Access to the Phone mode	Short button press
10 - <b>SETTINGS</b> (*)	Access to the main settings menu	Short button press
10 - <b>NAV</b> (**)	Access to the Navigation menu	Short button press
11 - <b>MEDIA</b>	Source selection: CD, USB/iPod, AUX, <b>Bluetooth®</b>	Short button press
12 - <b>RADIO</b>	Access to the Radio mode	Short button press

(\*) Versions with **Uconnect™** 5" Radio LIVE / (\*\*) Versions with **Uconnect™** 5" Radio Nav LIVE

## STEERING WHEEL CONTROLS

### Description

The controls for the main system functions are present on the steering wheel fig. 133 to make control easier.

The activation of the function selected is controlled, in some cases, by how long the button is pressed (short or long press) as described in the table below.









133

A0J0052C



ABC

## STEERING WHEEL CONTROL SUMMARY TABLE

Button	Interaction
	<ul style="list-style-type: none"> <li><input type="checkbox"/> Acceptance of incoming call</li> <li><input type="checkbox"/> Acceptance of the second incoming call and putting the active call on hold</li> <li><input type="checkbox"/> Activation of voice recognition for Phone function</li> <li><input type="checkbox"/> Interruption of the voice message in order to give a new voice command</li> <li><input type="checkbox"/> Interruption of voice recognition</li> </ul>
	<ul style="list-style-type: none"> <li><input type="checkbox"/> Rejection of incoming call</li> <li><input type="checkbox"/> Ending of call in progress</li> </ul>
	<ul style="list-style-type: none"> <li><input type="checkbox"/> Deactivate/reactivate the microphone during a phone conversation</li> <li><input type="checkbox"/> Activation/deactivation of the Pause function for CD, USB/iPod, <b>Bluetooth</b><sup>®</sup> sources</li> <li><input type="checkbox"/> Activation/deactivation of radio Mute function</li> </ul>
	<ul style="list-style-type: none"> <li><input type="checkbox"/> Adjustment of the audio volume: hands-free, text message reader, voice announcements and music sources</li> </ul>
	<ul style="list-style-type: none"> <li><input type="checkbox"/> Activation of voice recognition</li> <li><input type="checkbox"/> Interruption of the voice message in order to give a new voice command</li> <li><input type="checkbox"/> Interruption of voice recognition</li> </ul>
	<ul style="list-style-type: none"> <li><input type="checkbox"/> Short press (Radio mode): selection of next/previous station</li> <li><input type="checkbox"/> Long press (Radio mode): scan higher/lower frequencies until released</li> <li><input type="checkbox"/> Short press (CD, USB/iPod, <b>Bluetooth</b><sup>®</sup> mode): selection of previous/next track</li> <li><input type="checkbox"/> Long press (CD, USB/iPod, <b>Bluetooth</b><sup>®</sup> mode): fast forward/rewind until released</li> </ul>

## SWITCHING THE SYSTEM ON/OFF

The system is switched on/off by pressing the  (ON/OFF) button/knob. Turn the button/knob clockwise to increase the radio volume or anticlockwise to decrease it.

## RADIO (TUNER) MODE

Press the RADIO button on the front panel to activate radio mode. Select the band by pressing the corresponding button: "AM", "FM" or "DAB".

### Selecting a frequency band

Briefly press the "AM/FM" button to switch from AM to FM and vice versa. If the DAB tuner is available, briefly press the "AM/FM", "AM/DAB", "FM/DAB" buttons to select the desired band.

### Indications on display

After the desired radio station is selected, the following information is shown on the display:





**At the top:** the list of radio stations stored (presets) is displayed; the station currently playing is highlighted.

**In the middle:** display of the name of the current radio station and the buttons for selecting the previous or next radio station.

**At the bottom:** radio station selection,

radio band, tuning, track information and audio settings.

### Searching for the previous/next radio station

To search for the desired radio station, rotate the BROWSE ENTER button/knob, press the  or  buttons or use the steering wheel controls  .

When searching forwards, if the system reaches the end of the band, it will automatically stop on the station where the search has started from.

### Previous/next radio station fast search

Hold down buttons  or  on the display: when the button is released, the first tunable radio station will be displayed.

### Tuning the radio (AM/FM)

Press the "Tune" button on the display and then enter the frequency of the radio station using the keypad on the display.

In this mode, use buttons + and – to fine-tune the frequency.

To delete an incorrect number (and enter the correct station number) press the  (Delete) button.

After entering the last digit of the station, the screen is deactivated and the system tunes automatically to the station selected (the number of the radio station is displayed in the "Tune" text box).

The screen disappears automatically after 5 seconds or manually by pressing the "OK" or "X" buttons.

### Exit the "Direct Tune" screen

Press the "Exit" or "Radio" button on the display to return to the main system screen.



### DAB Radio

(where provided)

Once DAB radio mode is selected, the information on the current station is displayed and the following functions.

### Selection of the previous/next radio station by:

turning the BROWSE ENTER button/knob;

briefly pressing the  or  buttons on the display;

Steering wheel control press  .

Hold down the  or  buttons to fast scroll the station list.

### The "Browse" button is used to display:

- the list of all DAB stations;
- the list of stations filtered by "Genres";
- the list of stations filtered by "Ensembles" (broadcast group).

### Setting the presets

Presets are available in all system modes and are activated by touching one of the preset buttons located in the upper area of the display.

If you are tuned to a radio station that



ABC

you wish to store, hold down the button on the display which corresponds to the desired preset or until an acoustic confirmation signal is emitted.

The system can store up to 12 radio stations in each mode: 3 radio stations are displayed in the upper area.

Press the "All" button on the display to show all the radio stations stored in the frequency band selected.

### Audio

To access the "Audio" menu, press the APPS button on the front panel, scroll through the menu, then select and press the "Audio" option on the display.

The following adjustments can be carried out using the "Audio" menu:

- "Equaliser" (where provided): to adjust the bass, medium and treble tones;
- "Balance/Fader" (left/right and front/rear audio balance adjustment);
- "Volume/Speed" (excluding versions with Hi-Fi system) speed-dependent automatic volume adjustment;
- "Loudness" (where provided): improves audio quality at low volumes;
- "Auto-On Radio": provides the options of radio on, radio off or restore status when the ignition key was last turned to STOP;
- "Radio Off Delay": keeps the radio on for a preset time after the ignition key is turned to STOP.

### MEDIA MODE

Press the "Source" button to select the desired audio source among those available: CD, **Bluetooth**®, AUX, USB/iPod

#### Change track (next/previous)

Briefly press the  graphic button or press  on the steering wheel or, alternatively, turn the BROWSE ENTER button/knob clockwise to play the next track. Briefly press the  graphic button or press  on the steering wheel or, alternatively, turn the BROWSE ENTER button/knob clockwise to return to the beginning of the track or return to the beginning of the previous track of the track has been playing for less than 8 seconds.

#### Fast forward/rewind through tracks

Press and hold down the  button to fast forward the selected track or keep the  button pressed to fast rewind the track.

#### Track selection (Browse)

The selection options depend on the device connected or the CD type inserted.

Press the "Browse" button to activate this function on the source being played.

NOTE A few **Bluetooth**® devices do not offer the possibility of scrolling tracks through all categories.

NOTE Within each list, the "ABC" button

allows the user to skip to the desired letter in the list. This button might be disabled for some **Apple**® devices.

Turn the BROWSE ENTER button/knob to select the desired category and then press the button/knob to confirm the selection.

Press the "X" button to cancel the function.

#### Track information display

Press the "Info" button to display the information on the track being listened to for devices that support the function. Press the "X" button to exit the screen.

#### Shuffle

Press the ">" button then the "Shuffle" button to play the tracks on the CD, USB/iPod or **Bluetooth**® in a random order.

Press the "Shuffle" button again to deactivate the function.

#### Repeat

Press the ">" button then the "Repeat" button to activate the function.

Press the "Repeat" button again to deactivate the function.

## CD PLAYER

To activate CD mode, insert an audio or MP3 CD in the relevant slot or press the MEDIA button on the front panel. If the CD has already been inserted, press the "Source" button and then select "CD".

To load the CD, insert it gently into the slot to activate the motorised loading system, which will position it correctly (the "CD" symbol on the display comes on). Enter a CD when the system is on, the CD mode is automatically selected and the system starts playing the tracks.

Press the button ▲ (EJECT) on the front panel, with the system on, to eject the CD.

### Important notes

The presence of dirt, scratches or distortions on the CDs may cause skipping while it is playing and poor sound quality. Clean every CD thoroughly removing any fingerprints or dust using a soft cloth. Hold CDs by the outside edge and clean them from the middle outwards; Never use chemical products (e.g. antistatic, thinner or spray cans) for cleaning as they could damage the surface of the CDs. After listening to them place CDs back in their cases to avoid them being damaged. Do not expose CDs to direct sunlight, high temperatures or moisture for long periods.

## Bluetooth® SOURCE

### Pairing a Bluetooth® device

- activate the **Bluetooth®** function on the device;
- press the MEDIA button on the front panel;
- if the "Media" source is active, press the "Source" button;
- select the **Bluetooth®** Media source;
- press the "Add Device" button;
- look for **Uconnect™** on the **Bluetooth®** audio device.
- when requested by the audio device, enter the PIN code shown on the system display or confirm on the device the PIN displayed. Select "Yes" or "No" when asked if you want to set the **Bluetooth®** audio device as the favourite;
- an audio device can also be paired by pressing the APPS button on the front panel and then selecting "Settings" and "Bluetooth".

### USB/iPod SUPPORT



If a USB/iPod device is inserted with the system on, this starts playing the tracks present on the device.

## AUX SOURCE



When a device is inserted using the AUX output socket the system starts reproducing the AUX source connected, if it is already being played.

Adjust the volume using the  button/knob on the front panel or using the volume adjustment control on the connected device.

**IMPORTANT** The functions of the device connected with the AUX socket are directly managed by the device itself.

**IMPORTANT** Do not leave the cable of the portable player connected to the AUX socket after disconnection, to avoid possible hiss from the speakers.

### PHONE MODE

#### Activate phone mode

Press the PHONE button on the front panel to activate the Phone mode. A message on the display confirms connection of the phone.

To read the list of mobile phones and supported functions, visit the [www.driveuconnect.eu](http://www.driveuconnect.eu) website or call Customer Service number at 00800.2532.0000 (the number may vary depending on the country: please refer to the reference table in the paragraph "Customer Service number



ABC

list" in the **Uconnect™** attachments).

### Main functions

Use the buttons on the display to:

- ❑ dial the phone number (using the graphic keypad on the display);
- ❑ display and call the contacts in the mobile phone phonebook;
- ❑ display and call contacts from the registers of previous calls;
- ❑ pair up to 10 phones/audio devices to make access and connection easier and quicker;
- ❑ transfer calls from the system to the mobile phone and vice versa and deactivate the microphone audio for private conversations.

### Pairing a mobile phone

To pair the mobile phone, proceed as follows:

- ❑ activate the **Bluetooth®** function on the mobile phone;
- ❑ press the PHONE button on the front panel;
- ❑ if no phone is paired with the system yet, the display shows a dedicated screen;
- ❑ select "Yes" to start the pairing procedure, then search for the **Uconnect™** device on the mobile phone;
- ❑ when prompted by the mobile phone, use its keypad to enter the PIN code shown on the system display or confirm on the mobile phone the PIN displayed;

❑ from the "Phone" screen you can always pair a mobile phone by pressing the "Settings" button: press the "Add Device" button and proceed as described above;

❑ select "Yes" or "No" at the request to pair the mobile phone as the preferred device;

NOTE After updating the phone software, for proper operation, it is recommended to remove the phone from the list of devices linked to the radio, delete the previous system pairing also from the list of **Bluetooth®** devices on the phone and make a new pairing.

### Storing names/numbers in the mobile phone phonebook

Before pairing your mobile phone, make sure you have stored the names you want to contact in the phonebook on your mobile phone so that you can call them using the car's hands-free system.

### Transferring phone data (phonebook and recent calls)



If your mobile phone has a function for sending the phonebook via **Bluetooth®** technology.

Answer "Yes" when asked to copy the phonebook to the system. Answer "No" to carry out the operation later on.

### Making a phone call



The operations described below can only be accessed if supported by the mobile phone in use.

A call can be made by:

- ❑ selecting the  icon (mobile phone phonebook);
- ❑ selecting "Recent Calls";
- ❑ selecting the icon  (Keypad);
- ❑ pressing the "Redial" button.

### Handling an incoming call

The buttons on the display allow the following phone call functions to be managed:

- ❑ To answer a call: press the "Answer" button or the  button on the steering wheel controls;
- ❑ To end a call: press the "Ignore" button or the  button on the steering wheel controls;
- ❑ Ignore;
- ❑ Put on hold/resume;
- ❑ Deactivate/activate the microphone;
- ❑ Transfer the call;
- ❑ Switch from one call to the other;
- ❑ Conference/merge two active calls.

### Text message reader

To use this function the mobile phone must support the SMS exchange function through **Bluetooth®**.

If this function is not supported by the



phone, the corresponding  button is deactivated (grey).

When a text message is received, the display will show a screen where the options "Listen", "Call" or "Ignore" can be selected.

The list of SMS messages received from the mobile phone can be accessed by pressing the  button.

## NAVIGATION MODE

(Uconnect™ 5™ Radio Nav LIVE versions only)

### Programming a route

**IMPORTANT** In the interest of safety and to reduce distractions while you are driving, you should always plan a route before you start driving.

To plan a route, do the following:

- tap the screen to display the Navigation Main menu, then tap "Navigate to";
- select "Address": you can change the country or state setting by tapping the flag before you select a city;
- enter the town or city name, or the postcode. Towns with similar names are shown in the list while you type;
- enter the street name. Streets with similar names are shown in the list while you type. When the correct street name appears in the list, tap the name to select the destination;

enter the house number, then tap "Done";

the location is shown on the map. Tap "Select" to continue or "Back" to enter another address. If you want your final destination to be a car park, tap "Parking" and select a location from the list of car parks close to your general destination;

when the new route is shown, tap "Done". For more information about the route, tap "Details". To change a route tap "Change route".

### View Map

To view the map, tap "View map" or "View route", then "Show map of route" in the Main menu.

When the display shows the map, the following options are available:

- Map scale (high left corner);
  - Traffic: current traffic incidents. Use the "Options" button to select whether traffic information is shown on the map.
- When traffic information is shown on the map, "Points of Interest" and "My Places" are not shown;
- "Options" graphic button;
  - "Find" graphic button: Tap this button to find specific addresses, "My Places" or "Points of Interest";
  - Zoom bar: (bottom right corner): move the cursor to enlarge/reduce.

## Settings Menu

To access the "Settings" Menu tap "Settings" in the Main Menu. The following settings are available for the map:

- "2D/3D": allows to set the default map view (2D or 3D);
- "Advanced Settings": allows to select the following advanced settings:
  - "Car symbol": allows to select the car symbol that views the vehicle current position during drive;
  - "My Places": allows to add/rename/delete "My Places";
  - "GPS Status": allows to see the current status of GPS reception on your navigation system;
  - "Home location": allows to set/change your Home location;
  - "Keyboard": allows to select keyboards which need to be available (keyboards is necessary to enter names and addresses);
  - "Make your own menu": allows to add up to 6 buttons to your own personalised menu;
  - "Manage POIs": allows to manage your own Points of Interest (POI) categories and locations;
  - "Map colours": allows to select the view screen of map colours (day or night);
  - "Me and my navigation": allows to view technical information relating to the system;



ABC

- ❑ “Reset factory settings”: allows to delete all your personal navigation settings and restore the standard factory settings to your navigation system;
- ❑ “Route Planning”: allows to set the way your system calculates the routes that you plan;
- ❑ “Safety Settings”: allows to select the safety features you want applied to your navigation;
- ❑ “Show POI on map”: allows to select the types of Point of Interest (POI) you want to see on the map;
- ❑ “Status bar”: allows to select the information you want to see on the status bar:
- ❑ “Maps”: allows to select the map you want to use for route planning and navigation;
- ❑ “Enable/disable voice guide”: allows to enable (green button)/disable (red button) the voice guide during navigation;
- ❑ “Units”: allows to set the units used for navigation features (e.g. route planning);
- ❑ “Switch to day/night colours”: allows to select day or night view of display;
- ❑ “Voice settings”: allows to set the type of spoken directions and other route instructions that your system will read aloud;
- ❑ “Start”: allows to choose if the request for consent to the processing of data must be displayed or not displayed every time the system is turned on;

- ❑ “Navigation updates”: touch this button if you wish to prepare a USB device for the navigation map updates.

### “APPS” MODE

Press the APPS button on the front panel to display the following operating settings:

- ❑ External temperature
- ❑ Trip Computer
- ❑ Clock
- ❑ Compass (**Uconnect™** 5” Radio Nav LIVE versions only)
- ❑ **Uconnect™ LIVE**
- ❑ Settings (**Uconnect™** 5” Radio Nav LIVE versions only)

### **Uconnect™ LIVE SERVICES**

Press the APPS button to access the **Uconnect™ LIVE** apps.

The services available depend on the car configuration and the market. To use the **Uconnect™ LIVE** services, you need to download the **Uconnect™ LIVE** app from Google Play or Apple Store and register using the APP or on [www.driveuconnect.eu](http://www.driveuconnect.eu) website.

### **First access to the vehicle**

Once you have launched the **Uconnect™ LIVE** App and entered your details, in order to access the **Uconnect™ LIVE** services in your vehicle, you have to pair the **Bluetooth®** with your smartphone and the system. When

pairing is complete, the connected services can be accessed by pressing the **Uconnect™ LIVE** icon on the system.

Before you can use the connected services, you must first do the **Bluetooth®** pairing, then complete the activation procedure by following the instructions that appear in the **Uconnect™ LIVE** app.

### **Settings of the Uconnect™ LIVE services that can be managed through the radio**

From the dedicated radio menu for **Uconnect™ LIVE services** you can access the “Settings” section using the  In this section you can check the system options and change them to suit your own preferences.

### **System updates**

If an update for the **Uconnect™ LIVE** system is available while the **Uconnect™ LIVE** services are being used, the driver will be informed with a message on the display.

### **Connected services that can be accessed on the vehicle**

The Efficient Drive (where provided) and my:Car applications are developed to improve the customer driving experience, therefore they are available in all markets where the **Uconnect™ LIVE** services can be accessed.

On **Uconnect™** 5” Radio Nav LIVE

versions, the access to **Uconnect™LIVE** services enables the use of "Live" services.

### **Efficient Drive** (where provided)

The Efficient Drive application allows you to display your driving behaviour in real time, in order to help you reach a more efficient driving style as far as consumption and emissions are concerned.

Driving style is evaluated by means of four indices which monitor the following parameters: acceleration, deceleration, gearchange, speed

### **Display of the Efficient Drive** (where provided)

Press the Efficient Drive button to interact with the function.

On the **Uconnect™** display, a screen will appear showing 4 indices: "Acceleration", "Deceleration", "Speed" and "Gear". These indices are grey until the system has enough data to evaluate the driving style. Once sufficient data are available, the indices will have 5 colours depending on the evaluation: dark green (very good), light green, yellow, orange and red (very bad).

In the event of extended inactivity the display will show the average of the indices up to that moment ("Average

index") then the indices will be coloured again in real time as soon as the vehicle is restarted.

### **my:Car**

my:Car application allows you to keep the condition of your vehicle always under control.

my:Car can detect malfunction in real time and inform the driver about the expiry of the servicing interval. Press the "my:Car" button to interact with the application.

The display will show a screen with the "care:Index" section, which provides all the detailed information about the status of the vehicle. Press the "Active warnings" button to show (if present) the details of the vehicle's faults which caused a warning light to switch on.

### **SETTINGS**

Press SETTINGS button on the front panel (versions with **Uconnect™** 5" Radio LIVE) or APPS button and the graphic button "Settings" (versions with **Uconnect™** 5" Radio Nav LIVE) on the display to view the "Settings" main menu  
NOTE The menu items displayed vary according to the versions.

- Display;
- Voice (where provided);
- Measurement unit (where provided);
- Clock & Date;

- Safety/Assistance (where provided);
- Lights (where provided);
- Doors and Door lock;
- Audio;
- Phone/Bluetooth;
- Radio;
- Restore Default Settings;
- Clear personal data;
- Restore apps;
- DNA messages.

### **VOICE COMMANDS**

#### **Using voice commands**

The  button on the steering wheel activates the "Phone" voice recognition mode, there is a "beep" and the display shows a suggestion screen inviting the user to say a command.

If the  button is pressed during a system voice message, it activates the "Radio/Media" voice recognition mode that controls the radio and the USB/iPod/CD and MP3 players.

Please follow the suggestions below to be sure that the voice commands are always recognised by the system:

- speak at a normal volume;
- always wait for the "beep" (warning sound) before speaking;
- if possible, try and keep the noise in the passenger compartment to a minimum. It is also advisable to close the windows and sunroof (where provided).



ABC

□ for optimum operation, it is advisable to close the windows and the sun roof (where provided) to avoid external interference;

**IMPORTANT** Voice commands must always be given in safe driving conditions, in compliance with the laws in force in the country where you are driving and using the mobile phone correctly.

### Multiple choice

In a few specific cases the system cannot unambiguously identify the given voice command and asks the user to choose between a maximum of four alternatives. The system will propose a numbered list of the available alternatives, asking the user to say the associated number.

### ANTITHEFT PROTECTION

The system is equipped with an anti-theft protection system based on the exchange of information with the electronic control unit (Body Computer) on the vehicle. This guarantees maximum safety and prevents the secret code from being entered after the power supply has been disconnected. If the check has a positive outcome, the system will start to operate.

If the comparison codes are not the same or if the electronic control unit (Body Computer) is replaced, the system will ask the user to enter the secret code

according to the procedure described in the paragraph below.

### Entering the secret code

When the system is switched on, if the code is requested, the display will show "Please enter Anti-Theft Code" followed by the screen showing a keypad to enter the secret code.

The secret code is made up of four digits, from 1 to 9: to insert the first number of the code press the corresponding key on the display. Enter the other code digits in the same way. After entering the fourth digit, the system begins operating. If an incorrect code is entered, the system displays "Incorrect Code" to notify the user of the need to enter the correct code.

After the 3 available attempts to enter the code, the system displays "Incorrect Code. Radio locked. Please wait 30 minutes" (the waiting time is displayed). After the text has disappeared it is possible to start the code entering procedure again.

### Vehicle radio passport

This document certifies ownership of the system. The vehicle radio passport shows the system model, serial number and secret code.

In the event that the radio passport is lost, contact an Alfa Romeo Dealership,

taking an ID document and the car ownership documents.

**IMPORTANT** Keep the vehicle radio passport in a safe place so that you can give the information to the relevant authorities if the system is stolen.



### WARNING

**150)** When inserting a device (USB or iPod) in the USB port, make sure that it does not obstruct the operation of the handbrake lever.



### WARNING

**151)** When inserting a device in the AUX socket, make sure that it does not obstruct the operation of the handbrake lever.

## IMPORTANT INFORMATION AND RECOMMENDATIONS



### WARNING

#### **INTERIOR FITTINGS**

- Do not travel with the storage compartment open: it may injure the front seat occupants in the event of an accident.
- The cigar lighter gets extremely hot. Handle it carefully and make sure that children don't use it: risk of fire and/or burns.
- Do not use the ashtray as a waste paper basket: it may catch fire in contact with cigarette stubs.

#### **ROOF RACK/SKI RACK**

- After travelling for a few kilometres, check to ensure that the fixing screws for the attachments are well tightened.
- Never exceed the maximum permitted loads (see chapter "Technical specifications").
- Distribute the load evenly and pay attention to side winds when driving.

#### **ELECTRIC POWER STEERING**

- Before starting any servicing operation, stop the engine and remove the key from the ignition switch to operate the steering lock, particularly when the wheels do not touch the ground. If this is not possible (for example if the key needs to be turned to MAR or the engine must be running), remove the main fuse that protects the electric power steering.

#### **INTERIOR**

- Never use flammable products, such as petrol ether or rectified petrol to clean the inside of the car. The electrostatic charges which are generated by rubbing during the cleaning operation may cause a fire.
- Do not keep aerosol cans in the car: they might explode. Aerosol cans must not be exposed to a temperature exceeding 50°C. When the vehicle is exposed to sunlight, the internal temperature can greatly exceed this value.





## IMPORTANT

### **ROOF RACK/SKI RACK**

- Fully comply with the regulations in force concerning maximum clearance.

### **INTERIOR**

- Never use alcohol, petrols and derivatives to clean the dashboard and instrument panel lens.

# PETRONAS <sup>®</sup>*SELENIA*

*It's in the heart of your engine.*



Ask your mechanic for **PETRONAS  
<sup>®</sup>*SELENIA***

*Your car has chosen **PETRONAS Selenia***

*The engine of your car was made with **PETRONAS Selenia**, the range of engine oils that satisfies the most advanced international specifications. Subject to specific tests and boasting outstanding technical characteristics, **PETRONAS Selenia** is a lubricant designed to equip your engine with **reliable, winning performance standards**"*

---

*The quality of PETRONAS Selenia is divided into a range of technologically advanced products:*

#### **SELENIA WR FORWARD 0W-30/0W-20**

Fully synthetic, latest generation lubricant specifically formulated for EURO 6 diesel engines. Its fully synthetic formula and 0W-30 viscosity grade guarantee excellent performance in terms of fuel economy for diesel engines equipped with high efficiency turbo-charger. PETRONAS Selenia Forward also features excellent resistance to oxidation, thus maintaining its technical characteristics and promoting maximum engine performance throughout the entire oil-change interval.

#### **SELENIA DIGITEK P.E. 0W-30**

Is the fully synthetic lubricant created for the most modern petrol engines. Its special viscosity grade and its specific formulation enhance the fuel economy features and, consequently the reduction of CO2 emissions. Especially created for TwinAir two-cylinder engines, it ensures maximum engine protection even under high mechanical stress due to mainly city use.

#### **SELENIA MULTIPower C3**

Is a high performance synthetic lubricant designed for petrol and diesel engines requiring products able to reduce ash deposits to the absolute minimum. It provides increased protection against wear and tear and has excellent fuel economy characteristics. It protects the particle filter (DPF) in diesel engines.

#### **SELENIA SPORT POWER**

Is a fully synthetic lubricant designed to enhance the sporting characteristics of direct injection petrol engines (GDI). It maximizes sporting performances while maintaining complete engine protection, even under the most severe conditions of use.

The PETRONAS Selenia range is completed with Selenia StAR Pure Energy, Selenia StAR, Selenia WR Pure Energy, Selenia Sport, and Selenia Racing.

For further information concerning PETRONAS Selenia products, consult the website: [www.pli-petronas.com](http://www.pli-petronas.com)

---



**CHOOSING GENUINE PARTS IS  
THE MOST NATURAL CHOICE**



## HOW TO RECOGNISE GENUINE PARTS

To recognise a **Genuine Part**, check that the component bears our brands, always clearly visible on Genuine Parts, from the braking system to windscreen wipers, from shock absorbers to pollen filter.

All **Genuine Parts** undergo **strict controls**, both during design and manufacturing stages, by specialists using **vanguard materials**, to **test the component reliability**.

This to guarantee **performance** and **safety** for you and your passengers on board, for a long time.

Always ask for and make sure a **Genuine Part** has been used.



Pollen filter



Shock absorber

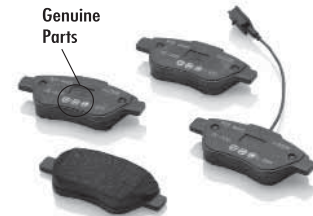

Brake pads

**MAINTAIN YOUR VEHICLE IN  
TIP TOP CONDITIONS WITH**



**Mopar Vehicle Protection** offers a series of service contracts that are designed to give all our customers the pleasure of driving their vehicle without any hitch's and concerns.

Our product portfolio consists of a wide and flexible range of **extended warranty and maintenance plans** endorsed by FCA. Each with a series of **different coverage tiers, in terms of durability and mileage**, built to accommodate you're driving needs.

Service contracts are made by experts that know every part of your vehicle, and commit themselves to **maintain it in tip top conditions**. Our knowledge and passion is tailored around designing products that promises all our drivers "worry-free driving".

Only with Mopar Vehicle Protection you are ensured that all service operations are performed by **highly qualified and specialized technicians in authorized FCA repair facilities, using the right tools, equipment and only original parts, all over Europe**.

Check which Service Contract plans are available on your market today and choose the Service Contract that suits your driving habits best.

Ask your local dealer for further information.

# NOTES

physicsclass.com





## INDEX

"Electronic Q2" system ("E-Q2") . . . . .	67	seats and fabric parts . . . . .	149	Engine coolant fluid . . . . .	142
"Alfa DNA" system . . . . .	34	Climate control . . . . .	24	Engine oil (level check). . . . .	142
"Smart Bag" system (multistage front airbags) . . . . .	81	Climate control/heating system. . . . .	24	EOBD system . . . . .	64
<b>A</b> BS system . . . . .	66	CO2 emissions . . . . .	178	ESC (Electronic Stability Control) system . . . . .	66
Active safety systems. . . . .	66	Control buttons. . . . .	42	External courtesy lights. . . . .	21
Alarm system . . . . .	13	Control panel and on-board instruments . . . . .	40	External lights . . . . .	19
Alfa Romeo Code system. . . . .	12	Cruise Control . . . . .	97	<b>F</b> itting "Universal" child restraint system . . . . .	76
Alfa TCT . . . . .	93	<b>D</b> aytime running lights (DRL) . . . . .	19	Fix&Go Automatic kit . . . . .	120
ALFA TCT transmission (key removal) . . . . .	124	Dimensions . . . . .	165	Flashing . . . . .	20
ASR (AntiSlip Regulation) system. . . . .	66	Dipped headlights (bulb replacement). . . . .	108	Fluids and lubricants. . . . .	172
Automatic dual-zone climate control system . . . . .	26	Direction indicators . . . . .	20	Follow Me Home (device). . . . .	21
<b>B</b> attery . . . . .	146	Direction indicators (bulb replacement). . . . .	109	Front airbag driver's side . . . . .	82
Battery (recharging) . . . . .	143	Display . . . . .	42	Front airbags . . . . .	81
Bodywork (maintenance) . . . . .	147	Door central locking/unlocking . . . . .	13	Front ceiling light. . . . .	21
Boot . . . . .	33	Door mirrors . . . . .	18	Front fog lights . . . . .	20
Brake Assist system. . . . .	66	Doors. . . . .	13	bulb replacement . . . . .	109
Brakes (fluid level) . . . . .	142	Driver side knee bag . . . . .	83	Front seats . . . . .	14
<b>C</b> arrying children safely . . . . .	75	DST system (Dynamic Steering Torque) . . . . .	66	Fuel consumption . . . . .	176
CBC (Cornering Brake Control) system . . . . .	67	Dusk sensor . . . . .	19	Fuel cut-off system . . . . .	123
Changing a wheel. . . . .	116	Dynamic suspension. . . . .	35	Fuel tank cap . . . . .	100
Checking levels . . . . .	137	<b>E</b> BD system . . . . .	66	Fuses (replacement). . . . .	110
Cleaning and maintenance		Electric sunroof . . . . .	30	<b>G</b> ear Shift Indicator . . . . .	42
bodywork . . . . .	147	Electric windows . . . . .	29	<b>H</b> andbrake . . . . .	91
leather parts. . . . .	149	Engine . . . . .	154	Hazard warning lights . . . . .	104
leather seats. . . . .	149	marking . . . . .	153	Head restraints. . . . .	16
		Engine bonnet . . . . .	32	Headlights. . . . .	34
				Headlight alignment corrector . . . . .	20



Light beam direction . . . . .	34	MSR system . . . . .	66	Rims and tyres provided . . . . .	159
Hill Holder system . . . . .	67	Multimedia		<b>S</b> afe Lock (device) . . . . .	11
<b>I</b> dentification data		Power on/off . . . . .	187	SBR system (Seat Belt Reminder) . . . . .	72
chassis marking . . . . .	153	<b>N</b> umber plate lights (bulb		Scheduled servicing . . . . .	128
engine marking . . . . .	153	replacement) . . . . .	110	Scheduled Servicing Plan . . . . .	129
identification data plate . . . . .	152	<b>P</b> arking lights . . . . .	19	Screen wiper/washer . . . . .	22
Ignition device . . . . .	11	Parking sensors . . . . .	98	Seat belts . . . . .	70
Installing a Universal Isofix child		Parking the vehicle . . . . .	91	Seat belts (using) . . . . .	70
restraint system . . . . .	79	Passenger side front airbag . . . . .	82	Seats . . . . .	14
Instrument panel . . . . .	8	Performance . . . . .	175	Servicing and maintenance	
Interior lights . . . . .	21	Pre-tensioners . . . . .	73	Demanding use of the car . . . . .	136
Interiors (cleaning) . . . . .	149	Load limiters . . . . .	73	periodic checks . . . . .	136
Isofix child restraint system setup . . . . .	79	<b>R</b> ain sensor . . . . .	22	Setup menu . . . . .	43
<b>J</b> ack . . . . .	116	Rear direction indicators (bulb		Side airbags (Side bag - Window	
Jump starting . . . . .	122	replacement) . . . . .	110	bag) . . . . .	86
<b>K</b> eys . . . . .	10	Rear fog light . . . . .	20	Side bags (front side airbags) . . . . .	86
Key with remote control . . . . .	10	Rear fog light/reversing light (bulb		Side lights/brake lights (bulb	
<b>L</b> ifting the vehicle . . . . .	147	replacement) . . . . .	110	replacement) . . . . .	110
Light bulbs		Rear light clusters (bulb		Side lights/daytime running lights	
types of bulbs . . . . .	105	replacement) . . . . .	109	(DRL) (bulb replacement) . . . . .	108
Luggage compartment		Rear seat . . . . .	15	Side lights/dipped beam	
Extending the luggage		Rear view mirrors . . . . .	18	headlights . . . . .	19
compartment . . . . .	34	Rear window wiper/washer . . . . .	23	Snow chains . . . . .	164
Luggage compartment		Reconfigurable multifunction		Sport front seats . . . . .	15
initialisation . . . . .	34	display . . . . .	40, 42	Start&Stop (system) . . . . .	95
<b>M</b> ain beam headlights . . . . .	19	Refuelling . . . . .	169	Starting the engine . . . . .	90, 122
Main beam headlights (bulb		Refuelling the vehicle . . . . .	100	Bump starting . . . . .	123
replacement) . . . . .	108	Replacing a bulb . . . . .	104	Steering lock . . . . .	11
Mechanical key . . . . .	10	exterior lights . . . . .	108	Steering wheel . . . . .	17
Menu items . . . . .	43	General instructions . . . . .	104	<b>T</b> echnical data . . . . .	152



Third brake lights bulb replacement . . . . .	110	Tyres (inflation pressure) . . . . .	162	Window bags (side airbags for head protection). . . . .	86
Towing the vehicle . . . . .	125	<b>U</b> sing the manual gearbox . . . . .	92	Windscreen / rear window washing (fluid level) . . . . .	142
Towing trailers . . . . .	99	<b>V</b> ehicle changes/alterations . . . . .	4	Windscreen/rear window wiper . .22,144	
TPMS (Tyre Pressure Monitoring System). . . . .	68	Version with LPG system . . . . .	36		
Trip Computer . . . . .	45	<b>W</b> arning lights and messages . . . . .	46		
Tyres		Weights . . . . .	166		
Fix&Go Automatic (kit) . . . . .	120	Wheels . . . . .	159		
		Wheels and tyres changing a wheel . . . . .	116		



FCA Italy S.p.A. - MOPAR - Technical Services - Service Engineering  
Largo Senatore G. Agnelli, 3 - 10040 Volvera - Turin (Italy)  
Print no. 604.90.005-04/2016-1 Edition

# ALFA ROMEO GENUINE SPARE PARTS AND ACCESSORIES

## PERFECT FOR YOUR VEHICLE, RIGHT DOWN TO THE SMALLEST DETAIL

The **Alfa Romeo Genuine Spare Parts and Accessories** follow the rigid component engineering and manufacturing specifications used in the assembly line to meet the technical specifications of your new Alfa Romeo and to enhance its style and performance. They undergo strict approval tests and **quality** controls to ensure they comply with **safety** and **environmental standards**.

All of the components on your new Alfa Romeo, from the smallest bulb to the most complex mechanical, electrical and electronic systems, are designed to work in harmony and guarantee you a comfortable and safe drive, in full respect for the environment. The Genuine Accessories fully enhance the style of your new vehicle.

Entrust **the experience and quality of Alfa Romeo Dealerships** to find the full range of Alfa Romeo Genuine Spare Parts and Accessories.

---

Find your nearest Dealership on [www.alfaromeo.com](http://www.alfaromeo.com)

---





*La meccanica delle emozioni*