

Designer's™ Data Sheet

Overvoltage Transient Suppressor

... designed for applications requiring a diode with reverse avalanche characteristics for use as reverse power transient suppressor.

Developed to suppress transients in the automotive system, this device operates in reverse mode as power zener diode and will protect expensive modules such as ignition, injection and autoblocking systems from overvoltage conditions.

- High Power Capability
- Economical

MAXIMUM RATINGS

Parameters	Symbol	Value	Unit
DC Blocking Voltage	V_R	23	V
Peak Repetitive Reverse Surge Current (Time Constant = 10 ms, $T_C = 25^\circ\text{C}$)	I_{RSM}	62	A
Non Repetitive Peak Surge Current (Halfwave, Single Phase, 50 Hz)	I_{FSM}	400	A
Storage Temperature	T_{stg}	-40 to +150	$^\circ\text{C}$
Maximum Operating Junction Temperature	T_J	-40 to +150	$^\circ\text{C}$

THERMAL CHARACTERISTICS

Parameters	Symbol	Value	Unit
Thermal Resistance Junction to Case	$R_{\theta JC}$	1.0	$^\circ\text{C/W}$

ELECTRICAL CHARACTERISTICS ($T_C = 25^\circ\text{C}$ unless otherwise noted)

Characteristic	Symbol	Min	Max	Unit
Instantaneous Forward Voltage ($I_F = 100\text{ A}$) (1)	V_F	—	1.1	V
Reverse Current ($V_R = 20\text{ V}$) (1)	I_R	—	5.0	μA
Breakdown Voltage ($I_Z = 100\text{ mA}$) (1)	$V_{(BR)}$	24	32	V
Breakdown Voltage ($I_Z = 80\text{ A}$, $T_C = 85^\circ\text{C}$, $PW = 80\ \mu\text{s}$)	$V_{(BR)}$	—	40	V
Breakdown Voltage Temperature Coefficient	$V_{(BR)TC}$	—	0.09	$\%/^\circ\text{C}$
Forward Voltage Temperature Coefficient ($I_F = 10\text{ mA}$)	V_{FTC}	—	-2.0*	$\text{mV}/^\circ\text{C}$

MECHANICAL CHARACTERISTICS

Finish	All External Surfaces are Corrosion Resistant
Polarity	Cathode to Terminal
Weight	1.78 g*
Maximum Temperature for Soldering	260 $^\circ\text{C}$ for 10 s Using Belt Furnace

1. Pulse Test: Pulse Width < 300 μs , Duty Cycle < 2%.

* Typical

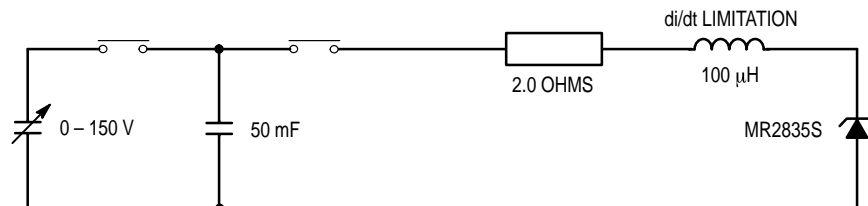
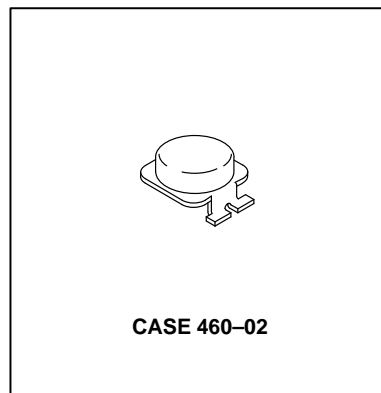
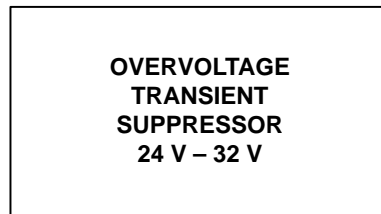

Figure 1. Load Dump Test Circuit

Designer's Data for "Worst Case" Conditions — The Designer's Data Sheet permits the design of most circuits entirely from the information presented. SOA Limit curves — representing boundaries on device characteristics — are given to facilitate "worst case" design.

REV 1



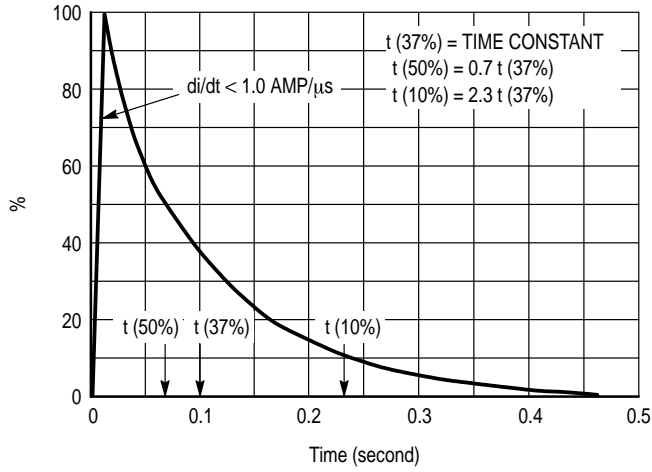

Figure 2. Load Dump Pulse Current

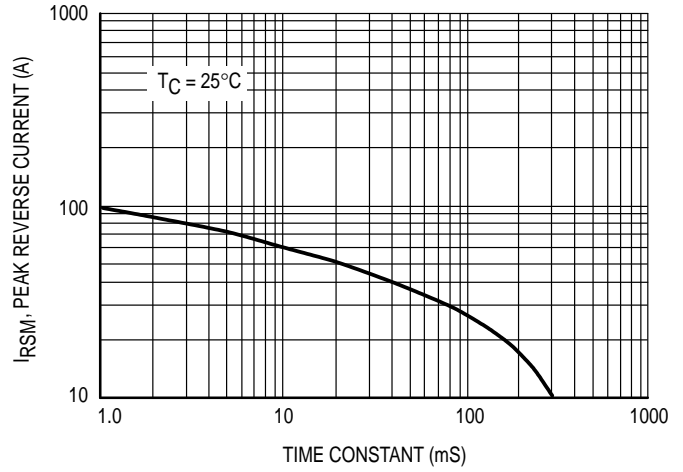

Figure 3. Maximum Peak Reverse Current

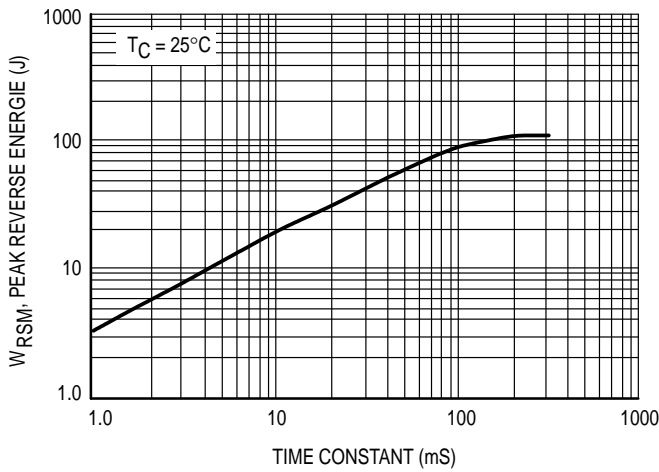

Figure 4. Maximum Reverse Energy

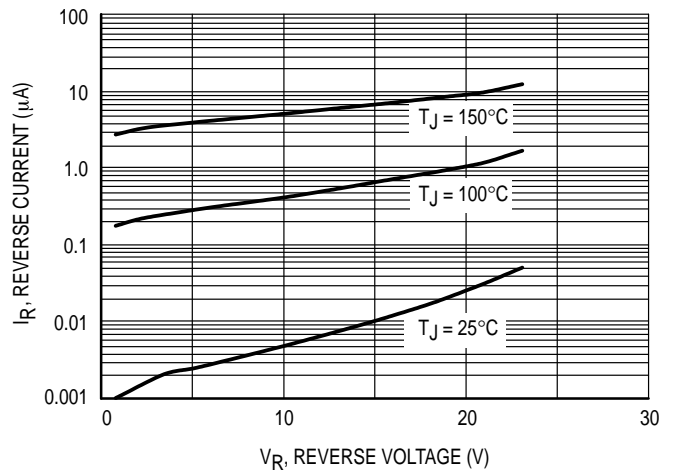

Figure 5. Typical Reverse Current

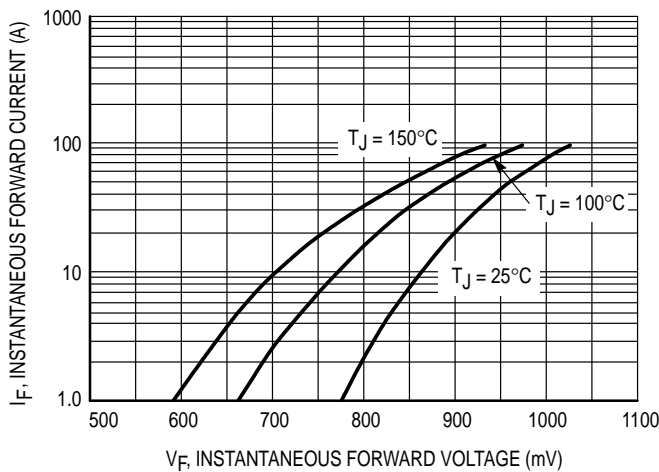

Figure 6. Typical Forward Voltage

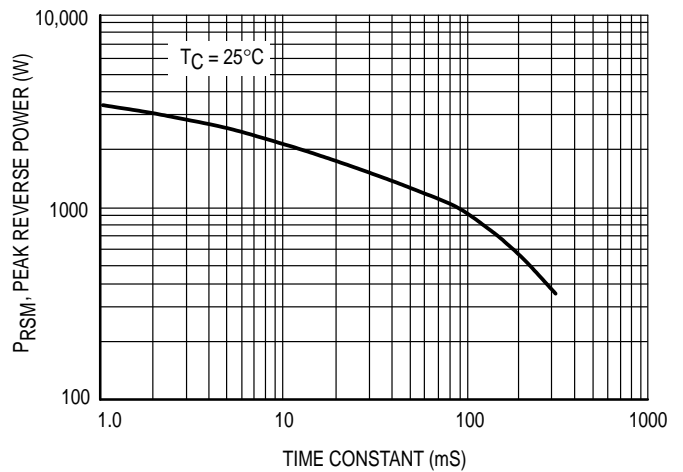

Figure 7. Maximum Peak Reverse Power

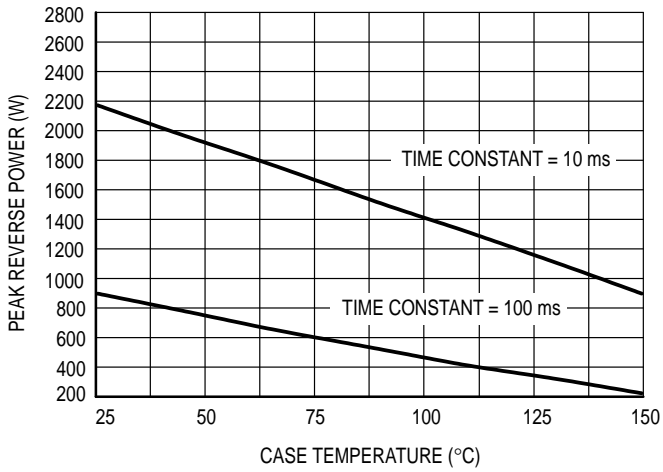

Figure 8. Reverse Power Derating

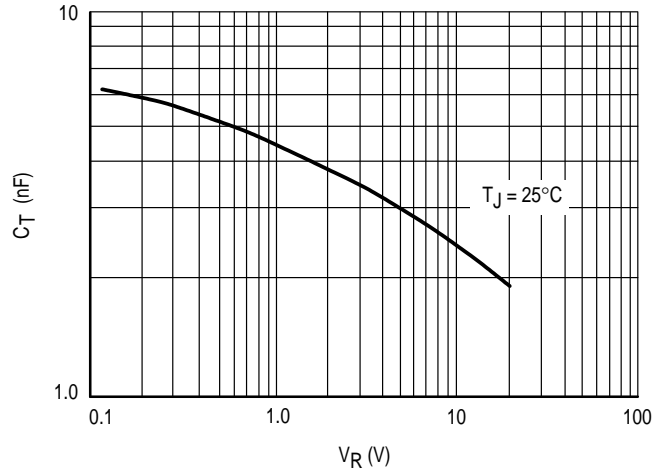

Figure 9. Typical Reverse Capacitance

Reel of 500 Units

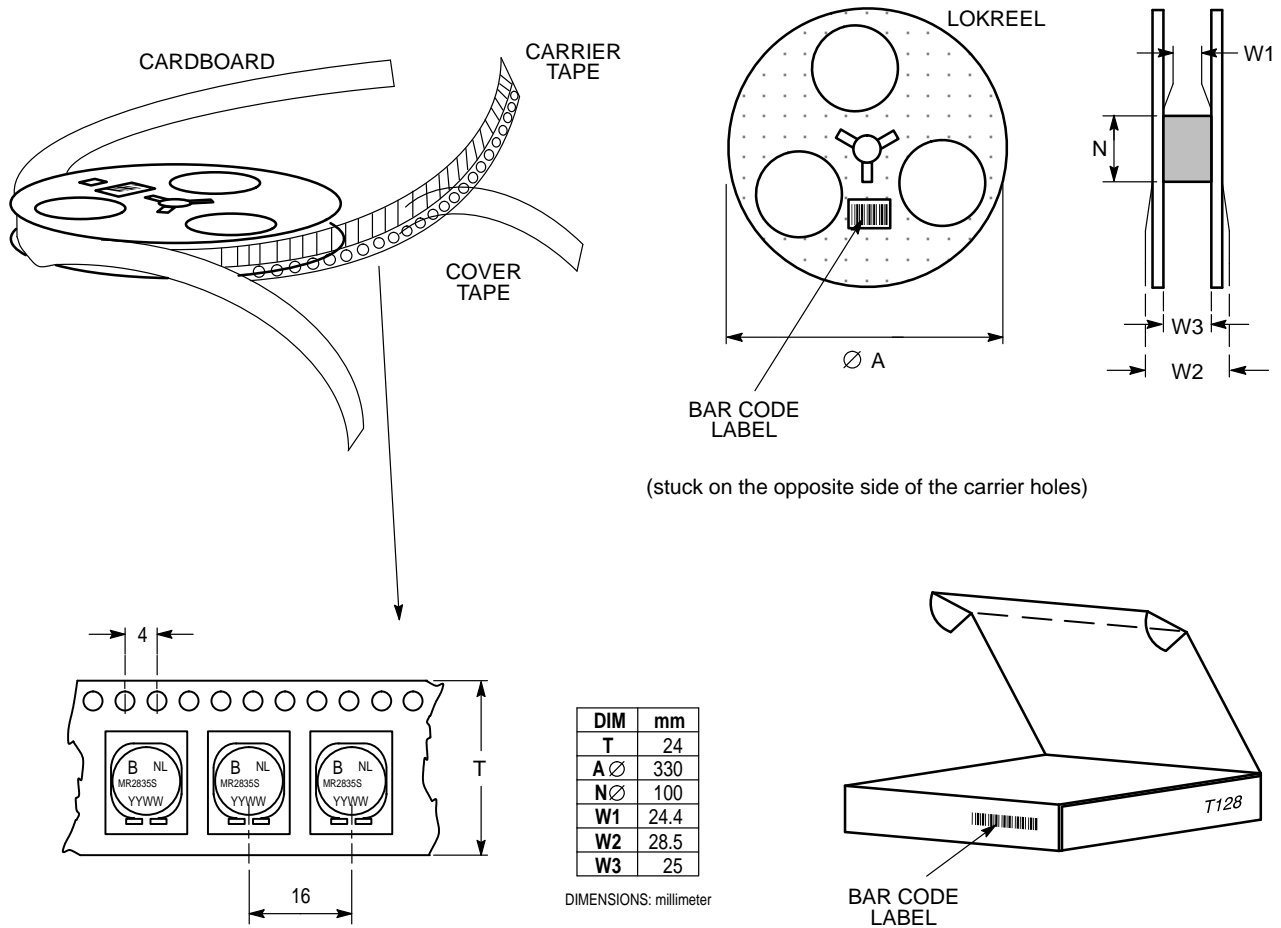
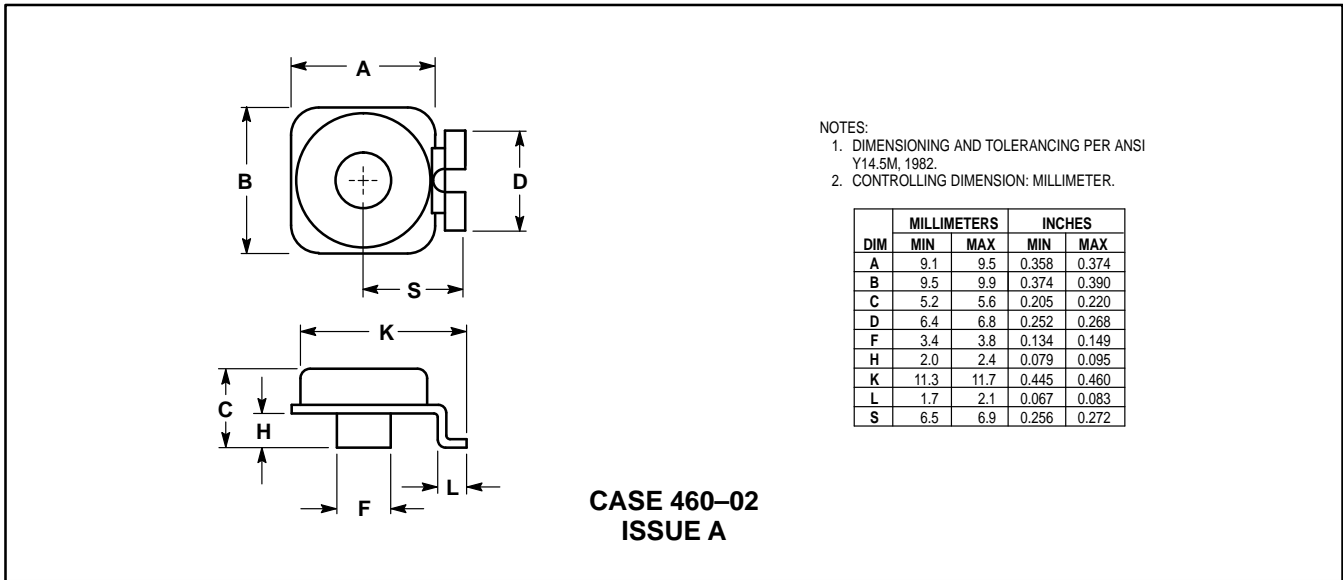
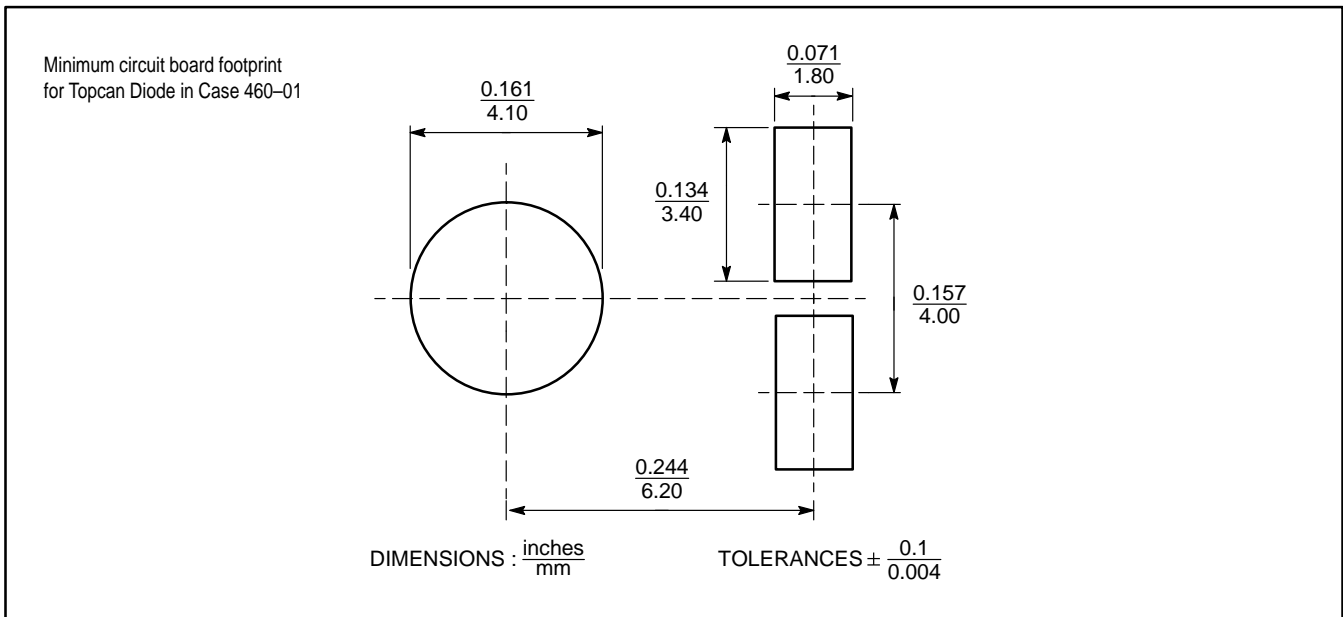

Figure 10. Reel Packing of MR2835S — Top Can

PACKAGE DIMENSIONS



FOOTPRINT



Motorola reserves the right to make changes without further notice to any products herein. Motorola makes no warranty, representation or guarantee regarding the suitability of its products for any particular purpose, nor does Motorola assume any liability arising out of the application or use of any product or circuit, and specifically disclaims any and all liability, including without limitation consequential or incidental damages. "Typical" parameters which may be provided in Motorola data sheets and/or specifications can and do vary in different applications and actual performance may vary over time. All operating parameters, including "Typicals" must be validated for each customer application by customer's technical experts. Motorola does not convey any license under its patent rights nor the rights of others. Motorola products are not designed, intended, or authorized for use as components in systems intended for surgical implant into the body, or other applications intended to support or sustain life, or for any other application in which the failure of the Motorola product could create a situation where personal injury or death may occur. Should Buyer purchase or use Motorola products for any such unintended or unauthorized application, Buyer shall indemnify and hold Motorola and its officers, employees, subsidiaries, affiliates, and distributors harmless against all claims, costs, damages, and expenses, and reasonable attorney fees arising out of, directly or indirectly, any claim of personal injury or death associated with such unintended or unauthorized use, even if such claim alleges that Motorola was negligent regarding the design or manufacture of the part. Motorola and are registered trademarks of Motorola, Inc. Motorola, Inc. is an Equal Opportunity/Affirmative Action Employer.

Mfax is a trademark of Motorola, Inc.

How to reach us:

USA/EUROPE/Locations Not Listed: Motorola Literature Distribution; P.O. Box 5405, Denver, Colorado 80217. 303-675-2140 or 1-800-441-2447

JAPAN: Nippon Motorola Ltd.; Tatsumi-SPD-JLDC, 6F Seibu-Butsuryu-Center, 3-14-2 Tatsumi Koto-Ku, Tokyo 135, Japan. 81-3-3521-8315

Mfax™: RMFA00@email.sps.mot.com – TOUCHTONE 602-244-6609
 – US & Canada ONLY 1-800-774-1848

ASIA/PACIFIC: Motorola Semiconductors H.K. Ltd.; 8B Tai Ping Industrial Park, 51 Ting Kok Road, Tai Po, N.T., Hong Kong. 852-26629298

INTERNET: <http://www.mot.com/SPS/>



This datasheet has been download from:

www.datasheetcatalog.com

Datasheets for electronics components.